

IRC TAG Significant Changes Review

2024 Code Section	TITLE OR SUBJECT	Reviewer Comments	Cost Yes/No	Amendment Needed Yes/No	TAG Comments/ Recommendation
CHAPTER 1 SCOPE AND ADMINISTRATION					
R101.2	Scope and General Requirements	See existing amendment report	No	YES, Modify Existing Amendment	
<p>R101.2 Scope. The provisions of this code shall apply to the construction, <i>alteration</i>, movement, enlargement, replacement, <i>repair</i>, equipment, use and occupancy, location, removal and demolition of detached one- and two-family <i>dwellings</i> and <i>townhouses</i> not more than three <i>stories above grade plane</i> in height with a separate means of egress and their <i>accessory structures</i> not more than three <i>stories above grade plane</i> in height.</p> <p>Exception: The following shall be permitted to be constructed in accordance with this code where provided with an automatic sprinkler system complying with Section P2904:</p> <ol style="list-style-type: none"> 1. Live/work units located in <i>townhouses</i> and complying with the requirements of Section 508.5 of the <i>International Building Code</i>. 2. <i>Owner-occupied lodging houses</i> with five or fewer <i>guestrooms</i>. 3. A care facility with five or fewer <i>persons</i> receiving custodial care within a <i>dwelling unit</i>. 4. A care facility with five or fewer persons receiving medical care within a <i>dwelling unit</i>. 5. A <i>day</i> care facility for five or fewer <i>persons of any age</i> receiving care within a <i>single-family dwelling unit</i>. 					
R102.6.1	Applicability			NO	
<p>R102.6.1 Additions, alterations, change of use or repairs. <i>Additions, alterations or repairs</i> to any <i>structure</i> shall conform to the requirements for a new structure without requiring the existing <i>structure</i> to comply with the requirements of this code, unless otherwise stated. <i>Additions, alterations, repairs</i> and relocations shall not cause an existing structure to become less compliant with the provisions of this code than the <i>existing building</i> or structure was prior to the <i>addition, alteration or repair</i>. An existing building together with its additions shall comply with the height limits of this code, the provisions of International Existing Building Code shall apply. Where additions, alterations or changes of use to an existing structure result in a use, occupancy, height or means of egress outside the scope of this code, the building shall comply with the International Existing Building Code.</p>					
R103	Code Compliance Agency	Section R103 Renamed		NO	
Section R103 Department of Building Safety Code Compliance Agency					
R103.1	Code Compliance Agency			NO	
<p>R103.1 Creation of enforcement agency. The department of building safety [INSERT NAME OF DEPARTMENT] is hereby created and the official in charge thereof shall be known as the <i>building official</i>. The function of the agency shall be the implementation, administration and enforcement of the provisions of this code.</p>					
R104.2	Duties and Powers of the Building Official			NO	
<p>R104.2 Determination of compliance. The building official shall have the authority to render interpretations of this code and to adopt policies and procedures in order to clarify the application of this code's provisions. Such interpretations, policies and procedures:</p> <ol style="list-style-type: none"> 1. Shall be in compliance with the intent and purpose of this code. 					

2024 Code Section	TITLE OR SUBJECT	Reviewer Comments	Cost Yes/No	Amendment Needed Yes/No	TAG Comments/ Recommendation
2. Shall not have the effect of waiving requirements specifically provided for in this code.					
R104.2.1	Duties and Powers of the Building Official			NO	
R104.2.1 Listed compliance. Where this code or a referenced standard requires equipment, materials, products or services to be <i>listed</i> and a listing standard is specified, the listing shall be based on the specified standard. Where a listing standard is not specified, the listing shall be based on an <i>approved</i> listing criteria. Listings shall be germane to the provision requiring the listing. Installation shall be in accordance with the listing and the manufacturer's instructions, and where required to verify compliance, the listing standard and manufacturer's instructions shall be made available to the <i>building official</i> .					
R104.2.2.1	Duties and Powers of the Building Official			NO	
R104.2.2.1 Approval authority. An alternative material, design or method of construction shall be approved where the <i>building official</i> finds that the proposed alternative is satisfactory and complies with Sections R104.2.2 through R104.2.2.6.2, as applicable.					
R104.2.2.2	Duties and Powers of the Building Official			NO	
R104.2.2.2 Application and disposition. Where required, a request to use an alternative material, design or method of construction shall be submitted in writing to the <i>building official</i> for approval. Where the alternative material, design or method of construction is not <i>approved</i> , the <i>building official</i> shall respond in writing, stating the reasons the alternative was not approved.					
R104.2.2.3	Duties and Powers of the Building Official			NO	
R104.2.2.3 Compliance with code intent. An alternative material, design or method of construction shall comply with the intent of the provisions of this code.					
R104.2.2.4	Duties and Powers of the Building Official			NO	
R104.2.2.4 Equivalency criteria. An alternative material, design or method of construction shall, for the purpose intended, be not less than the equivalent of that prescribed in this code with respect to all the following, as applicable: <ol style="list-style-type: none"> 1. Quality. 2. Strength. 3. Effectiveness. 4. Durability. 5. Safety, other than fire safety. 6. Fire safety. 					
R104.2.2.5	Duties and Powers of the Building Official			NO	

2024 Code Section	TITLE OR SUBJECT	Reviewer Comments	Cost Yes/No	Amendment Needed Yes/No	TAG Comments/ Recommendation
R104.2.2.5 Tests. Tests conducted to demonstrate equivalency in support of an alternative material, design or method of construction application shall be of a scale that is sufficient to predict performance of the end use configuration. Such tests shall be performed by a party acceptable to the <i>building official</i> .					
R104.2.2.6	Duties and Powers of the Building Official			NO	
R104.2.2.6 Reports. Supporting documentation, where necessary to assist in the approval of materials or assemblies not specifically provided for in this code, shall comply with Sections R104.2.2.6.1 and R104.2.2.6.2.					
R104.2.2.6.1	Duties and Powers of the Building Official			NO	
R104.2.2.6.1 Evaluation reports. Evaluation reports shall be issued by an <i>approved agency</i> and use of the evaluation report shall require approval by the <i>building official</i> for the installation. The alternate material, design or method of construction and product evaluated shall be within the scope of the <i>building official's</i> recognition of the <i>approved agency</i> . Criteria used for the evaluation shall be identified within the report and, where required, provided to the <i>building official</i>					
R104.2.2.6.2	Duties and Powers of the Building Official			NO	
R104.2.2.6.2 Other reports. Reports not complying with Section R104.2.2.6.1 shall describe criteria, including but not limited to any referenced testing or analysis, used to determine compliance with code intent and justify code equivalence. The report shall be prepared by a qualified engineer, specialist, laboratory or specialty organization acceptable to the building official. The <i>building official</i> is authorized to require design submittals to be prepared by, and bear the stamp of, a <i>registered design professional</i> .					
R104.4.1	Duties and Powers of the Building Official			NO	
R104.4.1 Warrant. Where the building code official has first obtained a proper inspection warrant or other remedy provided by law to secure entry, an <i>owner</i> , the <i>owner's</i> authorized agent, occupant or <i>person</i> having charge, care or control of the <i>structure</i> or premises shall not fail or neglect, after a proper request is made as herein provided, to permit entry therein by the building code official for the purposes of inspection and examination pursuant to this code.					
R104.7	Duties and Powers of the Building Official			NO	
R104.7 Official records. The <i>building official</i> shall keep official records as required in Sections R104.7.1 through R104.7.5. Such official records shall be retained for not less than 5 years or for as long as the building or structure to which such records relate remains in existence, unless otherwise provided by other regulations.					
R104.7.1	Duties and Powers of the Building Official			NO	

2024 Code Section	TITLE OR SUBJECT	Reviewer Comments	Cost Yes/No	Amendment Needed Yes/No	TAG Comments/ Recommendation
<p>R104.7.1 Approvals. A record of approvals shall be maintained by the <i>building official</i> and shall be available for public inspection during business hours in accordance with applicable laws.</p>					
R104.7.2	Duties and Powers of the Building Official			NO	
<p>R104.7.2 Inspections. The building official shall make the required inspections, or the building official shall have the authority to accept reports of inspection by approved agencies or individuals. Reports of such inspections shall be in writing and be certified by a responsible officer of such approved agency or by the responsible individual. The code official shall have the authority to conduct inspections, or shall accept reports of inspection by approved agencies or individuals. Reports of such inspections shall be in writing and be certified by a responsible officer of such approved agency or by the responsible individual. The <i>building official</i> is authorized to engage such expert opinion as deemed necessary to report on unusual technical issues that arise, subject to the approval of the appointing authority shall keep a record of each inspection made, including notices and orders issued, showing the findings and disposition of each.</p>					
R104.7.3	Duties and Powers of the Building Official			NO	
<p>R104.7.3 Code alternatives and modifications. Application for alternative materials, design and methods of construction and equipment in accordance with Section R104.2.2; modifications in accordance with Section R104.2.3; and documentation of the final decision of the <i>building official</i> for either shall be in writing and shall be retained in the official records.</p>					
R104.7.4	Duties and Powers of the Building Official			NO	
<p>R104.7.4 Tests. Tests. The <i>building official</i> shall keep a record of tests conducted to comply with Section R104.2.2.5.</p>					
R104.7.5	Duties and Powers of the Building Official			NO	

2024 Code Section	TITLE OR SUBJECT	Reviewer Comments	Cost Yes/No	Amendment Needed Yes/No	TAG Comments/ Recommendation
<p>R104.7.5 Fees. The <i>building official</i> shall keep a record of fees collected and refunded in accordance with Section R108.</p>					
CHAPTER 2 DEFINITIONS					
R202	Definitions	Chapter 11 Not adopted. Amendment Needed to remove from WARC	No	YES	
<p>[RB] ACCESS (TO). That which enables a device, an <i>appliance</i> or equipment to be reached by <i>ready access</i> or by a means that first requires the removal or movement of a panel, door or similar obstruction. For the definition applicable in Chapter 11, see Section N1101.6. For the definition applicable in Chapter 24, see Section G2403.</p>					
R202	Definitions		No	NO	
<p>[MP] AIR, EXHAUST. For the definition applicable in Chapter 24, see Section G2403.</p>					
R202	Definitions		No	NO	
<p>[MP] AIR, MAKEUP. Any combination of outdoor and transfer air intended to replace exhaust air and exfiltration. For the definition applicable in Chapter 24, see Section G2403.</p>					
R202	Definitions		No	NO	
<p>[MP] AIR, OUTDOOR. Ambient air that enters a building through a ventilation system, through intentional openings for natural ventilation or by infiltration.</p>					
R202	Definitions		No	NO	
<p>[MP] AIR, TRANSFER. Air moved from one indoor space to another.</p>					
R202	Definitions		No	NO	

2024 Code Section	TITLE OR SUBJECT	Reviewer Comments	Cost Yes/No	Amendment Needed Yes/No	TAG Comments/ Recommendation
[MP] AIR CONDITIONER, GAS-FIRED. For the definition applicable in Chapter 24, see Section G2403.					
R202	Definitions		No	NO	
[MP] AIR CONDITIONING. For the definition applicable in Chapter 24, see Section G2403.					
R202	Definitions	Chapter 11 Not adopted. Amendment Needed to remove from WARC	No	YES	
[MP] AIR-HANDLING UNIT. For the definition applicable in Chapter 24, see Section G2403. For the definition applicable in Chapter 11, see Section N1101.6.					
R202	Definitions		No	NO	
[MP] ANODELESS RISER. For the definition applicable in Chapter 24, see Section G2403.					
R202	Definitions		No	NO	
[MP] APPLIANCE, AUTOMATICALLY CONTROLLED. For the definition applicable in Chapter 24, see Section G2403.					
R202	Definitions		No	NO	
[MP] APPLIANCE, FAN-ASSISTED COMBUSTION. For the definition applicable in Chapter 24, see Section G2403.					
R202	Definitions		No	NO	
[MP] APPLIANCE, UNVENTED. For the definition applicable in Chapter 24, see Section G2403.					
R202	Definitions		No	NO	
[MP] APPLIANCE, VENTED. For the definition applicable in Chapter 24, see Section G2403.					
R202	Definitions		No	NO	
[MP] ATMOSPHERIC PRESSURE. For the definition applicable in Chapter 24, see Section G2403.					
R202	Definitions		No	NO	
[MP] AUTOMATIC IGNITION. For the definition applicable in Chapter 24, see Section G2403.					
R202	Definitions		No	NO	
[RE] AUTOMATIC SHUTOFF CONTROL. For the definition applicable in Chapter 11, see Section N1101.6					
R202	Definitions		No	NO	
[MP] BALANCED VENTILATION SYSTEM. A ventilation system where the total supply airflow and total exhaust airflow are simultaneously within 10 percent of their averages. The balanced ventilation system airflow is the average of the supply and exhaust airflows. A ventilation system that simultaneously supplies outdoor air to and exhausts air from a space, where the mechanical supply airflow rate and the mechanical exhaust airflow rate are within 10 percent of the average of the two airflow rates. For the definition applicable in Chapter 11, see Section N1101.6.					
R202	Definitions		No	NO	
[MP] BAROMETRIC DRAFT REGULATOR. For the definition applicable in Chapter 24, see Section G2403.					
R202	Definitions		No	NO	
[RE] BIODIESEL BLEND. For the definition applicable in Chapter 11, see Section N1101.6.					
R202	Definitions		No	NO	

2024 Code Section	TITLE OR SUBJECT	Reviewer Comments	Cost Yes/No	Amendment Needed Yes/No	TAG Comments/ Recommendation
<p>[MP] BOILER, LOW-PRESSURE. For the definition applicable in Chapter 24, see Section G2403. Hot water heating boiler. For the definition applicable in Chapter 24, see Section G2403. Hot water supply boiler. For the definition applicable in Chapter 24, see Section G2403. Steam heating boiler. For the definition applicable in Chapter 24, see Section G2403.</p>					
R202	Definitions		No	NO	
<p>[MP] BONDING JUMPER. For the definition applicable in Chapter 24, see Section G2403.</p>					
R202	Definitions		No	NO	
<p>[MP] BRAZING. For the definition applicable in Chapter 24, see Section G2403</p>					
R202	Definitions		No	NO	
<p>[MP] BTU. For the definition applicable in Chapter 24, see Section G2403</p>					
R202	Definitions		No	NO	
<p>[RB] BUILDING-INTEGRATED PHOTOVOLTAIC (BIPV) ROOF COVERING. A BIPV system that also functions as a roof covering. Coverings include, but are not limited to, shingles, tiles and roof panels.</p>					
R202	Definitions		No	NO	
<p>[RB] BUILDING-INTEGRATED PHOTOVOLTAIC PRODUCT (BIPV) SYSTEM. A building system that incorporates <i>photovoltaic modules</i> and functions as an integral part of the building envelope, such as <i>roof assemblies and roof coverings, exterior wall envelopes and exterior wall coverings, and fenestration.</i></p>					
R202	Definitions		No	NO	
<p>[MP] BURNER. For the definition applicable in Chapter 24, see Section G2403. Induced-draft. For the definition applicable in Chapter 24, see Section G2403. Power. For the definition applicable in Chapter 24, see Section G2403.</p>					
R202	Definitions	Chapter 11 Not adopted. Amendment Needed to remove from WARC	No	Yes	
<p>[RE] CAVITY INSULATION. For the definition applicable in Chapter 11, see Section N1101.6.</p>					
R202			No	NO	
<p>[MP] CHIMNEY. A primary vertical structure containing one or more flues, for the purpose of carrying gaseous products of combustion and air from a fuel-burning <i>appliance</i> to the outside atmosphere. For the definition applicable in Chapter 24, see Section G2403. Factory-built chimney. For the definition applicable in Chapter 24, see Section G2403. Masonry chimney. For the definition applicable in Chapter 24, see Section G2403.</p>					
R202	Definitions		No	NO	
<p>[MP] CLEARANCE. For the definition applicable in Chapter 24, see Section G2403.</p>					
R202	Definitions		No	NO	
<p>[MP] CLOTHES DRYER. For the definition applicable in Chapter 24, see Section G2403.</p>					

2024 Code Section	TITLE OR SUBJECT	Reviewer Comments	Cost Yes/No	Amendment Needed Yes/No	TAG Comments/ Recommendation
Type 1. For the definition applicable in Chapter 24, see Section G2403.					
R202	Definitions		No	NO	
[MP] CODE. For the definition applicable in Chapter 24, see Section G2403.					
R202	Definitions		No	NO	
[MP] CODE OFFICIAL. For the definition applicable in Chapter 24, see Section G2403.					
R202	Definitions		No	NO	
[MP] COMBUSTIBLE ASSEMBLY. For the definition applicable in Chapter 24, see Section G2403.					
R202	Definitions		No	NO	
[RB] COMBUSTIBLE MATERIAL. Any material not defined as noncombustible. For the definition applicable in Chapter 24, see Section G2403.					
R202	Definitions		No	NO	
[MP] COMBUSTION AIR. The air provided to fuel-burning equipment including air for fuel combustion, draft hood dilution and ventilation of the equipment enclosure. For the definition applicable in Chapter 24, see Section G2403.					
R202	Definitions		No	NO	
[MP] COMBUSTION CHAMBER. For the definition applicable in Chapter 24, see Section G2403.					
R202	Definitions		No	NO	
[MP] COMBUSTION PRODUCTS. For the definition applicable in Chapter 24, see Section G2403.					
R202	Definitions	Chapter 11 Not adopted. Amendment Needed to remove from WARC	No	YES	
[RE] COMMON AREAS. For the definition applicable in Chapter 11, see Section N1101.6.					
R202	Definitions		No	NO	
[MP] CONCEALED LOCATION. For the definition applicable in Chapter 24, see Section G2403.					
R202	Definitions		No	NO	
[MP] CONCEALED PIPING. For the definition applicable in Chapter 24, see Section G2403.					
R202	Definitions		No	NO	
[MP] CONDENSATE. The liquid that separates from a gas due to a reduction in temperature; for example, water that condenses from flue gases and water that condenses from air circulating through the cooling coil in air conditioning equipment. For the definition applicable in Chapter 24, see Section G2403.					
R202	Definitions		No	NO	
[MP] CONNECTOR, APPLIANCE (Fuel). For the definition applicable in Chapter 24, see Section G2403.					

2024 Code Section	TITLE OR SUBJECT	Reviewer Comments	Cost Yes/No	Amendment Needed Yes/No	TAG Comments/ Recommendation
R202	Definitions		No	NO	
[MP] CONNECTOR, CHIMNEY OR VENT. For the definition applicable in Chapter 24, see Section G2403.					
R202	Definitions	Chapter 11 Not adopted. Amendment Needed to remove last sentence from WARC	No	YES	
[RB] CONSTRUCTION DOCUMENTS. Written, graphic and pictorial documents prepared or assembled for describing the design, location and physical characteristics of the elements of a project necessary for obtaining a building permit. Construction drawings shall be drawn to an appropriate scale. For the definition applicable in Chapter 11, see Section N1101.6.					
R202	Definitions	Chapter 11 Not adopted. Amendment Needed to remove from WARC	No	YES	
[RE] CONTINUOUS PILOT. For the definition applicable in Chapter 11, see Section N1101.6.					
R202	Definitions		No	NO	
[MP] CONTROL. For the definition applicable in Chapter 24, see Section G2403.					
R202	Definitions		No	NO	
[MP] CONVERSION BURNER. For the definition applicable in Chapter 24, see Section G2403.					
R202	Definitions		No	NO	
[MP] COPPER ALLOY. For the definition applicable in Chapter 24, see Section G2403.					
R202	Definitions		No	NO	
[MP] CUBIC FOOT. For the definition applicable in Chapter 24, see Section G2403.					
R202	Definitions	Chapter 11 Not adopted. Amendment Needed to remove 1 st sentence from WARC	No	YES	
[MP] DAMPER. For the definition applicable in Chapter 11, see Section N1101.6. For the definition applicable in Chapter 24, see Section G2403.					
R202	Definitions		No	NO	
[MP] DECORATIVE APPLIANCE, VENTED. For the definition applicable in Chapter 24, see Section G2403.					
R202	Definitions		No	NO	

2024 Code Section	TITLE OR SUBJECT	Reviewer Comments	Cost Yes/No	Amendment Needed Yes/No	TAG Comments/ Recommendation
[MP] DECORATIVE APPLIANCES FOR INSTALLATION IN VENTED FIREPLACES. For the definition applicable in Chapter 24, see Section G2403.					
R202	Definitions	Word Glass changed to Glazing	No	NO	
[RB] DECORATIVE GLASS GLAZING. A carved, leaded or Dalle glass or glazing material with a purpose that is decorative or artistic, not functional; with coloring, texture or other design qualities or components that cannot be removed without destroying the glazing material; and with a surface, or assembly into which it is incorporated, that is divided into segments.					
R202	Definitions		No	NO	
[MP] DEMAND. For the definition applicable in Chapter 24, see Section G2403.					
R202	Definitions	Chapter 11 Not adopted. Amendment Needed to remove from WARC	No	YES	
[RE] DEMAND RESPONSE SIGNAL. For the definition applicable in Chapter 11, see Section N1101.6.					
R202	Definitions	Chapter 11 Not adopted. Amendment Needed to remove from WARC	No	YES	
[RE] DEMAND RESPONSIVE CONTROL. For the definition applicable in Chapter 11, see Section N1101.6.					
R202	Definitions		No	NO	
[MP] DESIGN FLOOD ELEVATION. For the definition applicable in Chapter 24, see Section G2403.					
R202	Definitions		No	NO	
[MP] DILUTION AIR. Air that enters a draft hood or draft regulator and mixes with flue gases. For the definition applicable in Chapter 24, see Section G2403.					
R202	Definitions	Chapter 11 Not adopted. Amendment Needed to remove from WARC	No	YES	
[RE] DIMMER. For the definition applicable in Chapter 11, see Section N1101.6.					
R202	Definitions		No	NO	

2024 Code Section	TITLE OR SUBJECT	Reviewer Comments	Cost Yes/No	Amendment Needed Yes/No	TAG Comments/ Recommendation
[MP] DIRECT-VENT APPLIANCE. A fuel-burning appliance with a sealed combustion system that draws all air for combustion from the outside atmosphere and discharges all flue gases to the outside atmosphere. For the definition applicable in Chapter 24, see Section G2403.					
R202	Definitions	Chapter 11 Not adopted. Amendment Needed to remove from WARC	No	YES	
[RE] DISTRIBUTION SYSTEM EFFICIENCY (DSE). For the definition applicable in Chapter 11, see Section N1101.6.					
R202	Definitions		No	NO	
<p>[MP] DRAFT. The pressure difference existing between the appliance or any component part and the atmosphere, that causes a continuous flow of air and products of combustion through the gas passages of the appliance to the atmosphere. For the definition applicable in Chapter 24, see Section G2403.</p> <p>Mechanical or induced draft. The pressure difference created by the action of a fan, blower or ejector, that is located between the appliance and the chimney or vent termination. For the definition applicable in Chapter 24, see Section G2403.</p> <p>Natural draft. The pressure difference created by a vent or chimney because of its height, and the temperature difference between the flue gases and the atmosphere. For the definition applicable in Chapter 24, see Section G2403.</p>					
R202	Definitions		No	NO	
[MP] DRAFT HOOD. A device built into an appliance, or a part of the vent connector from an appliance, that is designed to provide for the ready escape of the flue gases from the appliance in the event of no draft, backdraft or stoppage beyond the draft hood; prevent a backdraft from entering the appliance; and neutralize the effect of stack action of the chimney or gas vent on the operation of the appliance. For the definition applicable in Chapter 24, see Section G2403.					
R202	Definitions		No	NO	
[MP] DRAFT REGULATOR. A device that functions to maintain a desired draft in the appliance by automatically reducing the draft to the desired value. For the definition applicable in Chapter 24, see Section G2403.					
R202	Definitions		No	NO	
[MP] DRIP. For the definition applicable in Chapter 24, see Section G2403.					

2024 Code Section	TITLE OR SUBJECT	Reviewer Comments	Cost Yes/No	Amendment Needed Yes/No	TAG Comments/ Recommendation
R202	Definitions	Chapter 11 Not adopted. Amendment Needed to remove from WARC	No	YES	
[RE] DUCT AIRFLOW BALANCING. For the definition applicable in Chapter 11, see Section N1101.6.					
R202	Definitions		No	NO	
[MP] DUCT FURNACE. For the definition applicable in Chapter 24, see Section G2403.					
R202	Definitions	Chapter 11 Not adopted. Amendment Needed to remove from WARC	No	YES	
[RE] DUCTWORK. For the definition applicable in Chapter 11, see Section N1101.6.					
R202	Definitions	See Existing Amendment Report	No	YES: Incorporate New Language into existing Amendment	
[RB] DWELLING UNIT. A single unit providing complete independent living facilities for one or more persons, including permanent provisions for living, sleeping, eating, cooking and sanitation. For the definition applicable in Chapter 11, see Section N1101.6. For the definition applicable in Chapter 24, see Section G2403.					
R202	Definitions	Chapter 11 Not adopted. Amendment Needed to remove from WARC	No	YES	
[RE] EMITTANCE. For the definition applicable in Chapter 11, see Section N1101.6.					
R202	Definitions	Chapter 11 Not adopted. Amendment Needed to remove from WARC	No	YES	
[RE] ENCLOSED REFLECTIVE AIR SPACE. For the definition applicable in Chapter 11, see Section N1101.6.					

2024 Code Section	TITLE OR SUBJECT	Reviewer Comments	Cost Yes/No	Amendment Needed Yes/No	TAG Comments/ Recommendation
R202	Definitions	Chapter 11 Not adopted. Amendment Needed to remove from WARC	No	YES	
[RE] ENERGY RATING INDEX (ERI). For the definition applicable in Chapter 11, see Section N1101.6.					
R202	Definitions		No	NO	
[MP] EQUIPMENT. Piping, ducts, vents, control devices and other components of systems other than appliances that are permanently installed and integrated to provide control of environmental conditions for buildings. This definition shall also include other systems specifically regulated in this code. For the definition applicable in Chapter 24, see Section G2403.					
R202	Definitions		No	NO	
[MP] EXCESS FLOW VALVE (EFV). For the definition applicable in Chapter 24, see Section G2403.					
R202	Definitions	Chapter 11 Not adopted. Amendment Needed to remove last sentence from WARC	No	YES	
[RB] EXISTING BUILDING. Existing building is a building erected prior to the adoption of this code, or one for which a legal building permit has been issued. For the definition applicable in Chapter 11, see Section N1101.6.					
R202	Definitions		No	NO	
[MP] EXTERIOR MASONRY CHIMNEY. For the definition applicable in Chapter 24, see Section G2403.					
R202	Definitions		No	NO	
[RB] EXTERIOR SOFFIT. A material or assembly of materials applied on the underside of exterior overhangs and attached carport and porch ceilings.					
R202	Definitions		No	NO	
[RB] EXTERIOR WALL. An above-grade wall that defines the exterior boundaries of a building. Includes between-floor spandrels, peripheral edges of floors, roof and basement knee walls, dormer walls, gable end walls, gable end roof trusses, walls enclosing a mansard roof and basement walls with an average below-grade wall area that is less than 50 percent of the total opaque and nonopaque area of that enclosing side. For the definition applicable in Chapter 11, see Section N1101.6.					
R202	Definitions	Chapter 11 Not adopted. Amendment Needed to remove from WARC	No	YES	

2024 Code Section	TITLE OR SUBJECT	Reviewer Comments	Cost Yes/No	Amendment Needed Yes/No	TAG Comments/ Recommendation
[RE] F-FACTOR (THERMAL TRANSMITTANCE) . For the definition applicable in Chapter 11, see Section N1101.6.					
R202	Definitions	See Existing Amendment Report. Adds new defined term "townhouse unit"	No	YES: Incorporate new language into existing amendment	
<p>[RB] FIRE SEPARATION DISTANCE. The distance measured from the building face to one of the following:</p> <ol style="list-style-type: none"> 1. To the closest interior lot line. 2. To the centerline of a street, an alley or public way. 3. To an imaginary line between two buildings or townhouse units on the lot. <p>The distance shall be measured at a right angle from the face of the wall.</p>					
R202	Definitions		No	NO	
<p>[RB] FIREPLACE. An assembly consisting of a hearth and fire chamber of noncombustible material and provided with a chimney, for use with solid fuels. For the definition applicable in Chapter 24, see Section G2403.</p> <p>Factory-built fireplace. A listed and labeled fireplace and chimney system composed of factory-made components, and assembled in the field in accordance with manufacturer's instructions and the conditions of the listing. For the definition applicable in Chapter 24, see Section G2403.</p> <p>Masonry fireplace. A field-constructed fireplace composed of solid masonry units, bricks, stones or concrete. For the definition applicable in Chapter 24, see Section G2403.</p>					
R202	Definitions		No	NO	
[MP] FLAME SAFEGUARD. For the definition applicable in Chapter 24, see Section G2403.					
R202	Definitions		No	NO	
[MP] FLASHBACK ARRESTOR CHECK VALVE. For the definition applicable in Chapter 24, see Section G2403.					
R202	Definitions		No	NO	
[MP] FLOOD HAZARD AREA. For the definition applicable in Chapter 24, see Section G2403.					
R202	Definitions		No	NO	
<p>[MP] FLOOR FURNACE. A self-contained furnace suspended from the floor of the space being heated, taking air for combustion from outside such space, and with means for lighting the appliance from such space. For the definition applicable in Chapter 24, see Section G2403.</p>					

2024 Code Section	TITLE OR SUBJECT	Reviewer Comments	Cost Yes/No	Amendment Needed Yes/No	TAG Comments/ Recommendation
R202	Definitions		No	NO	
[MP] FLUE, APPLIANCE. The passages within an appliance through which combustion products pass from the combustion chamber to the flue collar. For the definition applicable in Chapter 24, see Section G2403.					
R202	Definitions		No	NO	
[MP] FLUE COLLAR. The portion of a fuel-burning appliance designed for the attachment of a draft hood, vent connector or venting system. For the definition applicable in Chapter 24, see Section G2403.					
R202	Definitions		No	NO	
[MP] FLUE GASES. Products of combustion plus excess air in appliance flues or heat exchangers. For the definition applicable in Chapter 24, see Section G2403.					
R202	Definitions		No	NO	
[MP] FLUE LINER (LINING). For the definition applicable in Chapter 24, see Section G2403.					
R202	Definitions	Chapter 11 Not adopted. Amendment Needed to remove 1 st sentence from WARC	No	YES	
[MP] FUEL GAS. For the definition applicable in Chapter 11, see Section N1101.6. For the definition applicable in Chapter 24, see Section G2403.					
R202	Definitions	Chapter 11 Not adopted. Amendment Needed to remove from WARC	No	YES	
[RE] FUEL OIL. For the definition applicable in Chapter 11, see Section N1101.6.					
R202	Definitions		No	NO	
[MP] FURNACE. A vented heating appliance designed or arranged to discharge heated air into a conditioned space or through a duct or ducts. For the definition applicable in Chapter 24, see Section G2403.					
R202	Definitions		No	NO	
[MP] FURNACE, CENTRAL. For the definition applicable in Chapter 24, see Section G2403.					
R202	Definitions		No	NO	
[MP] FURNACE PLENUM. For the definition applicable in Chapter 24, see Section G2403.					
R202	Definitions		No	NO	
[MP] GAS CONVENIENCE OUTLET. For the definition applicable in Chapter 24, see Section G2403.					

2024 Code Section	TITLE OR SUBJECT	Reviewer Comments	Cost Yes/No	Amendment Needed Yes/No	TAG Comments/ Recommendation
R202	Definitions		No	NO	
[MP] GAS PIPING. For the definition applicable in Chapter 24, see Section G2403.					
R202	Definitions	Chapter 11 Not adopted. Amendment Needed to remove last sentence from WARC	No	YES	
[RB] GRADE PLANE. A reference plane representing the average of the finished ground level adjoining the building a tall exterior walls. Where the finished ground level slopes away from the exterior walls, the reference plane shall be established by the lowest points within the area between the building and the lot line or, where the lot line is more than 6 feet (1829 mm) from the building between the structure and a point 6 feet (1829 mm) from the building. For the definition applicable in Chapter 11, see Section N1101.6.					
R202	Definitions		No	NO	
[RB] GYPSUM BOARD. The generic name for a family of sheet products A type of gypsum panel product consisting of a noncombustible core primarily of gypsum with paper surfacing. Gypsum wallboard, gypsum sheathing, gypsum base for gypsum veneer plaster, exterior gypsum soffit board, predecorated gypsum board and water-resistant gypsum backing board complying with the standards listed in Section R702.3 and Part IX of this code are types of gypsum board.					
R202	Definitions	New language taken from 2021 definition of GYPSUM BOARD	No	NO	
[RB] GYPSUM PANEL PRODUCT. The general name for a family of sheet products consisting essentially of gypsum complying with the standards specified in Section R702.3 and Chapter 44 of this code.					
R202	Definitions		No	NO	
[MP] HAZARDOUS LOCATION. Any location considered to be a fire hazard for flammable vapors, dust, combustible fibers or other highly combustible substances. For the definition applicable in Chapter 24, see Section G2403.					
R202	Definitions	Chapter 11 Not adopted. Amendment Needed to remove from WARC	No	YES	
[RE] HEAT EXCHANGER. For the definition applicable in Chapter 11, see Section N1101.6.					
R202	Definitions		No	NO	
[MP] HEAT PUMP. An appliance having heating or heating and cooling capability and that uses refrigerants to extract heat from air, liquid or other sources. A refrigeration system or factory-made appliance that utilizes refrigerant to transfer heat into a space or substance.					

2024 Code Section	TITLE OR SUBJECT	Reviewer Comments	Cost Yes/No	Amendment Needed Yes/No	TAG Comments/ Recommendation
R202	Definitions		No	NO	
[MP] IGNITION PILOT. For the definition applicable in Chapter 24, see Section G2403.					
R202	Definitions		No	NO	
[MP] IGNITION SOURCE. A flame, spark or hot surface capable of igniting flammable vapors or fumes. Such sources include appliance burners, burner ignitors and electrical switching devices. For the definition applicable in Chapter 24, see Section G2403.					
R202	Definitions	Definition expanded to include #2	No	NO	
[RB] IMPACT PROTECTIVE SYSTEM. Impact protective systems are defined as follows: 1. Construction that has been shown by testing to withstand the impact of test missiles and that is applied, attached or locked over exterior glazing. 2. For storm shelters, an assembly or device, subject to static or cyclic pressure and impact testing as detailed in ICC 500, installed to protect an opening in the storm shelter envelope.					
R202	Definitions		No	NO	
[MP] INFRARED RADIANT HEATER. For the definition applicable in Chapter 24, see Section G2403.					
R202	Definitions	Chapter 11 Not adopted. Amendment Needed to remove from WARC	No	YES	
[RE] INTERMITTENT IGNITION. For the definition applicable in Chapter 11, see Section N1101.6.					
R202	Definitions	Chapter 11 Not adopted. Amendment Needed to remove from WARC	No	YES	
[RE] INTERRUPTED IGNITION. For the definition applicable in Chapter 11, see Section N1101.6.					
R202	Definitions		No	NO	
[MP] JOINT, FLARED. For the definition applicable in Chapter 24, see Section G2403.					
R202	Definitions		No	NO	
[MP] JOINT, MECHANICAL. For the definition applicable in Chapter 24, see Section G2403.					
R202	Definitions		No	NO	
[MP] JOINT, PLASTIC ADHESIVE. For the definition applicable in Chapter 24, see Section G2403.					
R202	Definitions	Chapter 11 Not adopted. Amendment Needed to remove from WARC	No	YES	

2024 Code Section	TITLE OR SUBJECT	Reviewer Comments	Cost Yes/No	Amendment Needed Yes/No	TAG Comments/ Recommendation
[RE] KNEE WALL. For the definition applicable in Chapter 11, see Section N1101.6.					
R202	Definitions		No	NO	
[RB] LABELED. Equipment, materials or products to which have been affixed a label, seal, symbol or other identifying mark of a nationally recognized testing laboratory, approved agency or other organization concerned with product evaluation that maintains periodic inspection of the production of such labeled items and whose labeling indicates either that the equipment, material or product meets identified standards or has been tested and found suitable for a specified purpose. For the definition applicable in Chapter 11, see Section N1101.6. For the definition applicable in Chapter 24, see Section G2403.					
R202	Definitions		No	NO	
[MP] LEAK CHECK. For the definition applicable in Chapter 24, see Section G2403.					
R202	Definitions		No	NO	
[MP] LIQUEFIED PETROLEUM GAS OR LPG (LP-GAS). For the definition applicable in Chapter 24, see Section G2403.					
R202	Definitions	Chapter 11 Not adopted. Amendment Needed to remove from WARC	No	YES	
[RE] LIQUID FUEL. For the definition applicable in Chapter 11, see Section N1101.6.					
R202	Definitions		No	NO	

2024 Code Section	TITLE OR SUBJECT	Reviewer Comments	Cost Yes/No	Amendment Needed Yes/No	TAG Comments/ Recommendation
[RB] LISTED. Equipment, materials, products or services included in a list published by an organization acceptable to the code official and concerned with evaluation of products or services that maintains periodic inspection of production of listed equipment or materials or periodic evaluation of services and whose listing states either that the equipment, material, product or service meets identified standards or has been tested and found suitable for a specified purpose. Terms that are used to identify listed equipment, products or materials include "listed," "certified," "classified" or other terms as determined appropriate by the listing organization. For the definition applicable in Chapter 11, see Section N1101.6. For the definition applicable in Chapter 24, see Section G2403.					
R202	Definitions	Chapter 11 Not adopted. Amendment Needed to remove second to last sentence from WARC	No	YES	
[MP] LIVING SPACE. Space within a dwelling unit utilized for living, sleeping, eating, cooking, bathing, washing and sanitation purposes. For the definition applicable in Chapter 11, see Section N1101.6. For the definition applicable in Chapter 24, see Section G2403.					
R202	Definitions		No	NO	
[MP] LOG LIGHTER. For the definition applicable in Chapter 24, see Section G2403.					
R202	Definitions	Chapter 11 Not adopted. Amendment Needed to remove from WARC	No	YES	
[RE] LOW SLOPE. For the definition applicable in Chapter 11, see Section N1101.6.					
R202	Definitions		No	NO	
[MP] MAIN BURNER. For the definition applicable in Chapter 24, see Section G2403.					
R202	Definitions		No	NO	
[MP] METER. For the definition applicable in Chapter 24, see Section G2403.					
R202	Definitions		No	NO	
[MP] MODULATING. For the definition applicable in Chapter 24, see Section G2403.					
R202	Definitions		No	NO	
[RB] NONCOMBUSTIBLE MATERIAL. A material that passes ASTM E136. For the definition applicable in Chapter 24, see Section G2403.					

2024 Code Section	TITLE OR SUBJECT	Reviewer Comments	Cost Yes/No	Amendment Needed Yes/No	TAG Comments/ Recommendation
R202	Definitions	Chapter 11 Not adopted. Amendment Needed to remove from WARC	No	YES	
[RE] OCCUPANT SENSOR CONTROL. For the definition applicable in Chapter 11, see Section N1101.6.					
R202	Definitions	Chapter 11 Not adopted. Amendment Needed to remove from WARC	No	YES	
[RE] OCCUPIABLE SPACE. For the definition applicable in Chapter 11, see Section N1101.6.					
R202	Definitions		No	NO	
[MP] OFFSET (VENT). For the definition applicable in Chapter 24, see Section G2403.					
R202	Definitions	Chapter 11 Not adopted. Amendment Needed to remove from WARC	No	YES	
[RE] ON-DEMAND PILOT. For the definition applicable in Chapter 11, see Section N1101.6.					
R202	Definitions	Chapter 11 Not adopted. Amendment Needed to remove from WARC	No	YES	
[RE] ON-SITE RENEWABLE ENERGY. For the definition applicable in Chapter 11, see Section N1101.6.					
R202	Definitions		No	NO	
[MP] OUTLET. For the definition applicable in Chapter 24, see Section G2403.					
R202	Definitions		No	NO	
[MP] OXYGEN DEPLETION SAFETY SHUTOFF SYSTEM (ODS). For the definition applicable in Chapter 24, see Section G2403.					
R202	Definitions		No	NO	
[RB] PAN FLASHING. Corrosion-resistant flashing at the base of an opening that is integrated into the building exterior wall to direct water to the water-resistive barrier surface or to the exterior and is premanufactured, fabricated, formed or applied at the job site.					
R202	Definitions	Adds "(PV)" to title	No	NO	
[RB] PHOTOVOLTAIC (PV) MODULE. A complete, environmentally protected unit consisting of solar cells, optics and other components, exclusive of a tracker, designed to generate DC power where exposed to sunlight.					
R202	Definitions	Adds "(PV)" to title	No	NO	
[RB] PHOTOVOLTAIC (PV) PANEL. A collection of photovoltaic modules mechanically fastened together, wired, and designed to provide afield-installable unit.					

2024 Code Section	TITLE OR SUBJECT	Reviewer Comments	Cost Yes/No	Amendment Needed Yes/No	TAG Comments/ Recommendation
R202	Definitions	Adds "(PV)" to title	No	NO	
[RB] PHOTOVOLTAIC (PV) PANEL SYSTEM. A system that incorporates discrete photovoltaic panels that convert solar radiation into electricity, including rack support systems.					
R202	Definitions	New Definition	No	NO	
[RB] PHOTOVOLTAIC (PV) PANEL SYSTEM, GROUND-MOUNTED. An independent photovoltaic (PV) panel system without usable space underneath, installed directly on the ground.					
R202	Definitions	New Definition	No	NO	
[RB] PHOTOVOLTAIC (PV) SUPPORT STRUCTURE, ELEVATED. An independent photovoltaic (PV) panel support structure designed with usable space underneath with a clear height of not less than 7 feet 6 inches (2286 mm), intended for secondary use such as providing shade or parking of motor vehicles.					
R202	Definitions		No	NO	
[MP] PILOT. For the definition applicable in Chapter 24, see Section G2403.					
R202	Definitions		No	NO	
[MP] PIPING. For the definition applicable in Chapter 24, see Section G2403. PIPE. For the definition applicable in Chapter 24, see Section G2403. TUBING. For the definition applicable in Chapter 24, see Section G2403.					
R202	Definitions		No	NO	
[MP] PIPING SYSTEM. For the definition applicable in Chapter 24, see Section G2403.					
R202	Definitions		No	NO	
[MP] PLASTIC, THERMOPLASTIC. For the definition applicable in Chapter 24, see Section G2403.					
R202	Definitions	Chapter 11 Not adopted. Amendment Needed to remove last sentence from WARC		YES	
[MP] PLENUM. A chamber that forms part of an air-circulation system other than the occupied space being conditioned. For the definition applicable in Chapter 11, see Section N1101.6.					
R202	Definitions		No	NO	
[MP] POINT OF DELIVERY. For the definition applicable in Chapter 24, see Section G2403.					
R202	Definitions		No	NO	

2024 Code Section	TITLE OR SUBJECT	Reviewer Comments	Cost Yes/No	Amendment Needed Yes/No	TAG Comments/ Recommendation
[MP] PRESS-CONNECT JOINT. A permanent mechanical joint incorporating an elastomeric seal or an elastomeric seal and corrosion-resistant grip or bite ring. The joint is made with a pressing tool and jaw or ring approved by the fitting manufacturer. For the definition applicable in Chapter 24, see Section G2403.					
R202	Definitions		No	NO	
[MP] PRESSURE DROP. For the definition applicable in Chapter 24, see Section G2403.					
R202	Definitions		No	NO	
[MP] PRESSURE TEST. For the definition applicable in Chapter 24, see Section G2403.					
R202	Definitions		No	NO	
[MP] PURGE. To clear of air, gas or other foreign substances. For the definition applicable in Chapter 24, see Section G2403.					
R202	Definitions	Chapter 11 Not adopted. Amendment Needed to remove from WARC	No	YES	
[RE] RADIANT BARRIER. For the definition applicable in Chapter 11, see Section N1101.6.					
R202	Definitions	New Definition	No	NO	
[RB] RAINSCREEN SYSTEM. An assembly applied to the exterior side of an exterior wall which consists of, at minimum, an outer layer, an inner layer and a cavity between them sufficient for the passive removal of liquid water and water vapor.					
R202	Definitions	Chapter 11 Not adopted. Amendment Needed to remove second to last sentence from WARC	No	YES	
[RB] READY ACCESS (TO). That which enables a device, appliance or equipment to be directly reached, without requiring the removal or movement of any panel, door or similar obstruction. For the definition applicable in Chapter 11, see Section N1101.6. For the definition applicable in Chapter 24, see Section G2403.					
R202	Definitions	Chapter 11 Not adopted. Amendment Needed to remove from WARC	No	YES	
[RE] REFLECTIVE INSULATION. For the definition applicable in Chapter 11, see Section N1101.6.					
R202	Definitions		No	NO	

2024 Code Section	TITLE OR SUBJECT	Reviewer Comments	Cost Yes/No	Amendment Needed Yes/No	TAG Comments/ Recommendation
	[MP] REFRIGERANT. A substance used to produce refrigeration by its expansion or evaporation. The fluid used for heat transfer in a refrigeration system that undergoes a change of state to absorb heat.				
R202	Definitions	Replaces term "REFRIGERATING SYSTEM"	No	NO	
	[MP] REFRIGERATION SYSTEM. A combination of interconnected parts forming a closed circuit in which refrigerant is enclosed and circulated for the purpose of extracting, then rejecting, heat. A direct refrigerating system is one in which the evaporator or condenser of the refrigerating system is in direct contact with the air or other substances to be cooled or heated. An indirect refrigerating system is one in which a secondary coolant cooled or heated by the refrigerating system is circulated to the air or other substance to be cooled or heated.				
R202	Definitions		No	NO	
	[MP] REGULATOR. For the definition applicable in Chapter 24, see Section G2403.				
R202	Definitions		No	NO	
	[MP] REGULATOR, GAS APPLIANCE. For the definition applicable in Chapter 24, see Section G2403.				
R202	Definitions		No	NO	
	[MP] REGULATOR, LINE GAS PRESSURE. For the definition applicable in Chapter 24, see Section G2403.				
R202	Definitions		No	NO	
	[MP] REGULATOR, MEDIUM-PRESSURE (MP REGULATOR). For the definition applicable in Chapter 24, see Section G2403.				
R202	Definitions		No	NO	
	[MP] REGULATOR, MONITORING. For the definition applicable in Chapter 24, see Section G2403.				
R202	Definitions		No	NO	
	[MP] REGULATOR, PRESSURE. For the definition applicable in Chapter 24, see Section G2403.				
R202	Definitions		No	NO	
	[MP] REGULATOR, SERVICE PRESSURE. For the definition applicable in Chapter 24, see Section G2403.				
R202	Definitions		No	NO	
	[MP] RELIEF OPENING. For the definition applicable in Chapter 24, see Section G2403.				
R202	Definitions		No	NO	
	[MP] RELIEF VALVE (DEVICE). For the definition applicable in Chapter 24, see Section G2403.				
R202	Definitions		No	NO	
	[MP] RELIEF VALVE, PRESSURE. For the definition applicable in Chapter 24, see Section G2403.				

2024 Code Section	TITLE OR SUBJECT	Reviewer Comments	Cost Yes/No	Amendment Needed Yes/No	TAG Comments/ Recommendation
R202	Definitions		No	NO	
<p>[MP] RELIEF VALVE, TEMPERATURE. For the definition applicable in Chapter 24, see Section G2403. MANUAL REST TYPE. For the definition applicable in Chapter 24, see Section G2403. RESEATING OR SELF-CLOSING TYPE. For the definition applicable in Chapter 24, see Section G2403.</p>					
R202	Definitions		No	NO	
<p>[MP] RELIEF VALVE, VACUUM. A device to prevent excessive buildup of vacuum in a pressure vessel. For the definition applicable in Chapter 24, see Section G2403.</p>					
R202	Definitions	Chapter 11 Not adopted. Amendment Needed to remove from WARC	No	YES	
<p>[RE] RENEWABLE ENERGY CERTIFICATE (REC). For the definition applicable in Chapter 11, see Section N1101.6.</p>					
R202	Definitions	Chapter 11 Not adopted. Amendment Needed to remove from WARC	No	YES	
<p>[RE] RENEWABLE ENERGY RESOURCES. For the definition applicable in Chapter 11, see Section N1101.6.</p>					
R202	Definitions	New Definition	No	NO	
<p>[RB] RESPONSIVE VAPOR RETARDER. A vapor retarder material complying with a vapor retarder class of Class I or Class II but which also has a vapor permeance of 1 perm or greater in accordance with ASTM E96, water method (Procedure B).</p>					
R202	Definitions		No	NO	
<p>[MP] RISER, GAS. For the definition applicable in Chapter 24, see Section G2403.</p>					
R202	Definitions		No	NO	
<p>[MP] ROOM HEATER, UNVENTED. For the definition applicable in Chapter 24, see Section G2403.</p>					
R202	Definitions		No	NO	
<p>[MP] ROOM HEATER, VENTED. For the definition applicable in Chapter 24, see Section G2403.</p>					
R202	Definitions		No	NO	
<p>[MP] SERVICE METER ASSEMBLY. For the definition applicable in Chapter 24, see Section G2403.</p>					
R202	Definitions		No	NO	
<p>[MP] SHAFT. For the definition applicable in Chapter 24, see Section G2403.</p>					
R202	Definitions	Chapter 11 Not adopted. Amendment Needed to remove from WARC	No	YES	

2024 Code Section	TITLE OR SUBJECT	Reviewer Comments	Cost Yes/No	Amendment Needed Yes/No	TAG Comments/ Recommendation
[RE] SIMULATED BUILDING PERFORMANCE. For the definition applicable in Chapter 11, see Section N1101.6.					
R202	Definitions	Chapter 11 Not adopted. Amendment Needed to remove from WARC	No	YES	
[RE] SKYLIGHT. For the definition applicable in Chapter 11, see Section N1101.6 under "Fenestration."					
R202	Definitions	New Definition	No	NO	Tag to clarify application across code. Potential Amendment
[RB] SLEEPING LOFT. A space designated for sleeping on an intermediate level or levels between the floor and ceiling of a story, open on one or more sides to the room in which the space is located, and in accordance with Section R315.					
R202	Definitions	Chapter 11 Not adopted. Amendment Needed to remove last sentence from WARC	No	YES	
[RB] SLEEPING UNIT. A single unit that provides rooms or spaces for one or more persons, includes permanent provisions for sleeping and can include provisions for living, eating and either sanitation or kitchen facilities but not both. Such rooms and spaces that are also part of a dwelling unit are not sleeping units. For the definition applicable in Chapter 11, see Section N1101.6.					
R202	Definitions		No	NO	
[RB] SOLAR ENERGY SYSTEM. A system that converts solar radiation to usable energy, including photovoltaic panel systems, BIPV systems and solar thermal systems.					
R202	Definitions	Chapter 11 Not adopted. Amendment Needed to remove from WARC	No	YES	
[RE] SOLAR-READY ZONE. For the definition applicable in Chapter 11, see Section N1101.6.					
R202	Definitions	Chapter 11 Not adopted. Amendment Needed to remove from WARC	No	YES	
[RE] SPACE CONDITIONING. For the definition applicable in Chapter 11, see Section N1101.6.					

2024 Code Section	TITLE OR SUBJECT	Reviewer Comments	Cost Yes/No	Amendment Needed Yes/No	TAG Comments/ Recommendation
R202	Definitions	Chapter 11 Not adopted. Amendment Needed to remove from WARC	No	YES	
[RE] SPACE CONDITIONING EQUIPMENT. For the definition applicable in Chapter 11, see Section N1101.6.					
R202	Definitions		No	NO	
[MP] SPECIFIC GRAVITY. For the definition applicable in Chapter 24, see Section G2403.					
R202	Definitions	Chapter 11 Not adopted. Amendment Needed to remove from WARC	No	YES	
[RE] STEEP SLOPE. For the definition applicable in Chapter 11, see Section N1101.6.					
R202	Definitions	New Definition	No	NO	
[RB] SUBSTANTIAL DAMAGE. Damage of any origin sustained by a structure whereby the cost of restoring the structure to its before-damaged condition would equal or exceed 50 percent of the market value of the structure before the damage occurred.					
R202	Definitions	New Definition. Chapter 11 Not adopted. Amendment Needed to remove from WARC	No	YES	

2024 Code Section	TITLE OR SUBJECT	Reviewer Comments	Cost Yes/No	Amendment Needed Yes/No	TAG Comments/ Recommendation
<p>[RB] SUBSTANTIAL IMPROVEMENT. Any repair, reconstruction, rehabilitation, alteration, addition or other improvement of a building or structure, the cost of which equals or exceeds 50 percent of the market value of the structure before the improvement or repair is started. If the structure has sustained substantial damage, any repairs are considered substantial improvement regardless of the actual repair work performed. The term does not, however, include either:</p> <ol style="list-style-type: none"> 1. Any project for improvement of a building required to correct existing health, sanitary or safety code violations identified by the building official and that are the minimum necessary to assure safe living conditions. 2. Any alteration of a historic structure provided that the alteration will not preclude the structure's continued designation as a historic structure. For the purposes of this exclusion, a historic building shall be any of the following: <ol style="list-style-type: none"> 2.1. Listed or preliminarily determined to be eligible for listing in the National Register of Historic Places. 2.2. Determined by the Secretary of the US Department of Interior as contributing to the historical significance of a registered historic district or a district preliminarily determined to qualify as a historic district. 2.3. Designated as historic under a state or local historic preservation program that is approved by the Department of Interior. <p>For the definition applicable in Chapter 11, see Section N1101.6.</p>					
R202	Definitions		No	NO	
<p>[MP] SYSTEM SHUTOFF. For the definition applicable in Chapter 24, see Section G2403.</p>					
R202	Definitions	Chapter 11 Not adopted. Amendment Needed to remove from WARC	No	YES	
<p>[RE] TESTING UNIT ENCLOSURE AREA. For the definition applicable in Chapter 11, see Section N1101.6.</p>					

2024 Code Section	TITLE OR SUBJECT	Reviewer Comments	Cost Yes/No	Amendment Needed Yes/No	TAG Comments/ Recommendation
R202	Definitions	Chapter 11 Not adopted. Amendment Needed to remove from WARC	No	YES	
[RE] THERMAL DISTRIBUTION EFFICIENCY (TDE). For the definition applicable in Chapter 11, see Section N1101.6.					
R202	Definitions	Chapter 11 Not adopted. Amendment Needed to remove first sentence from WARC	No	YES	
[RE] THERMOSTAT. For the definition applicable in Chapter 11, see Section N1101.6. For the definition applicable in Chapter 24, see Section G2403. ELECTRIC SWITCH TYPE. For the definition applicable in Chapter 24, see Section G2403. INTEGRAL GAS VALVE TYPE. For the definition applicable in Chapter 24, see Section G2403.					
R202	Definitions		No	NO	
[MP] THIRD-PARTY CERTIFICATION AGENCY. An approved agency operating a product or material certification system that incorporates initial product testing, assessment and surveillance of a manufacturer's quality control system. For the definition applicable in Chapter 24, see Section G2403.					
R202	Definitions		No	NO	
[MP] THIRD-PARTY CERTIFIED. Certification obtained by the manufacturer indicating that the function and performance characteristics of a product or material have been determined by testing and ongoing surveillance by an approved third-party certification agency. Assertion of certification is in the form of identification in accordance with the requirements of the third-party certification agency. For the definition applicable in Chapter 24, see Section G2403.					
R202	Definitions		No	NO	
[MP] THIRD-PARTY TESTED. For the definition applicable in Chapter 24, see Section G2403.					
R202	Definitions		No	NO	
[MP] TOILET, GAS FIRED. For the definition applicable in Chapter 24, see Section G2403.					
R202	Definitions		No	NO	

2024 Code Section	TITLE OR SUBJECT	Reviewer Comments	Cost Yes/No	Amendment Needed Yes/No	TAG Comments/ Recommendation
[MP] TRANSITION FITTINGS, PLASTIC TO STEEL. For the definition applicable in Chapter 24, see Section G2403.					
R202	Definitions	New Definition	No	NO	
[RB] TYPE X. A type of gypsum panel product with special core additives to increase the fire resistance as specified by the applicable standards listed in Section R702.3 (see the definition of "Gypsum panel product").					
R202	Definitions		No	NO	
[MP] UNIT HEATER. For the definition applicable in Chapter 24, see Section G2403.					
R202	Definitions		No	NO	
[MP] UNVENTED ROOM HEATER. For the definition applicable in Chapter 24, see Section G2403.					
R202	Definitions		No	NO	
[MP] VALVE. For the definition applicable in Chapter 24, see Section G2403. APPLIANCE SHUTOFF. For the definition applicable in Chapter 24, see Section G2403. AUTOMATIC. For the definition applicable in Chapter 24, see Section G2403. AUTOMATIC GAS SHUTOFF. For the definition applicable in Chapter 24, see Section G2403. INDIVIDUAL MAIN BURNER. For the definition applicable in Chapter 24, see Section G2403. MAIN BURNER CONTROL. For the definition applicable in Chapter 24, see Section G2403. MANUAL MAIN GAS-CONTROL. For the definition applicable in Chapter 24, see Section G2403. MANUAL RESET. For the definition applicable in Chapter 24, see Section G2403. SERVICE SHUTOFF. For the definition applicable in Chapter 24, see Section G2403.					
R202	Definitions		No	NO	
[MP] VENT. A passageway for conveying flue gases from fuel-fired appliances, or their vent connectors, to the outside atmosphere. For the definition applicable in Chapter 24, see Section G2403.					
R202	Definitions		No	NO	
[MP] VENT CONNECTOR. That portion of a venting system that connects the flue collar or draft hood of an appliance to a vent. For the definition applicable in Chapter 24, see Section G2403.					
R202	Definitions		No	NO	
[MP] VENT PIPING. For the definition applicable in Chapter 24, see Section G2403. BREATHER. For the definition applicable in Chapter 24, see Section G2403. RELIEF. For the definition applicable in Chapter 24, see Section G2403.					
R202	Definitions		No	NO	
[MP] VENTED APPLIANCE CATEGORIES. For the definition applicable in Chapter 24, see Section G2403. CATEGORY I. For the definition applicable in Chapter 24, see Section G2403.					

2024 Code Section	TITLE OR SUBJECT	Reviewer Comments	Cost Yes/No	Amendment Needed Yes/No	TAG Comments/ Recommendation
<p>CATEGORY II. For the definition applicable in Chapter 24, see Section G2403. CATEGORY III. For the definition applicable in Chapter 24, see Section G2403. CATEGORY IV. For the definition applicable in Chapter 24, see Section G2403.</p>					
R202	Definitions		No	NO	
[MP] VENTED ROOM HEATER. For the definition applicable in Chapter 24, see Section G2403.					
R202	Definitions		No	NO	
[MP] VENTED WALL FURNACE. For the definition applicable in Chapter 24, see Section G2403.					
R202	Definitions		No	NO	
[MP] VENTING SYSTEM. A continuous open passageway from the flue collar of an appliance to the outside atmosphere for the purpose of removing flue or vent gases. A venting system is usually composed of a vent or a chimney and vent connector, if used, assembled to form the open passageway. For the definition applicable in Chapter 24, see Section G2403.					
R202	Definitions		No	NO	
[MP] WALL HEATER, UNVENTED TYPE. For the definition applicable in Chapter 24, see Section G2403.					
R202	Definitions		No	NO	
[MP] WATER HEATER. Any heating appliance or equipment that heats potable water and supplies such water to the potable hot water distribution system. For the definition applicable in Chapter 24, see Section G2403.					
R202	Definitions		No	NO	
[RB] WINDBORNE DEBRIS REGION. Areas within hurricane-prone regions located in accordance with one of the following: 1. Within 1 mile (1.61 km) of the mean high-water line where an Exposure D condition exists upwind at the water line and the ultimate design wind speed, V_{ult} , is 130 mph (58 m/s) or greater. 2. In areas where the ultimate design wind speed, V_{ult} , is 140 mph (63 m/s) or greater; or Hawaii.					
R202	Definitions	Chapter 11 Not adopted. Amendment Needed to remove from WARC	No	YES	

2024 Code Section	TITLE OR SUBJECT	Reviewer Comments	Cost Yes/No	Amendment Needed Yes/No	TAG Comments/ Recommendation
<p>[RE] WORK AREA. For the definition applicable in Chapter 11, see Section N1101.6.</p>					
CHAPTER 3 BUILDING PLANNING					
T R301.2 footnote d	Design Criteria		No	NO	
<p>d. The jurisdiction shall fill in this part of the table with the wind speed from the basic wind speed ultimate design wind speeds map [Figure R301.2(2)]. Wind exposure category shall be determined on a site-specific basis in accordance with Section R301.2.1.4.</p>					
T R301.2 footnote o	Design Criteria	ICC Approved for correlation reasons with ASCE 7-22	Increase See ICC RB 34-22	NO	

2024 Code Section	TITLE OR SUBJECT	Reviewer Comments	Cost Yes/No	Amendment Needed Yes/No	TAG Comments/ Recommendation
<p>o. The jurisdiction shall fill in this section of the ground snow loads allowable stress design table using the Ground Snow Loads in Figure R301.2(3).</p>					
F R301.2(2)	Design Criteria	ICC Approved for correlation reasons with ASCE 7-22	Increase See ICC RB 35-22	No	
<p>FIGURE R301.2(2) ULTIMATE DESIGN WIND SPEEDS</p> <p>Notes:</p> <ol style="list-style-type: none"> 1. Values are 3-second gust wind speeds in miles per hour (m/s) at 33 feet (10 m) above ground for Exposure Category C. 2. Linear interpolation is permitted between contours. Point values are provided to aid with interpolation. 3. Islands, coastal areas and land boundaries outside the last contour shall use the last wind speed contour. 4. Location-specific basic wind speeds shall be permitted to be determined using the ASCE Wind Design Geodatabase. 5. Wind speeds for Hawaii, US Virgin Islands and Puerto Rico shall be determined from the ASCE Wind Design Geodatabase. 6. Mountainous terrain, gorges, ocean promontories and special wind regions shall be examined for unusual wind conditions. Site specific values for selected special wind regions shall be permitted to be determined using the ASCE Wind Design Geodatabase. 7. Wind speeds correspond to approximately a 7-percent probability of exceedance in 50 years (Annual Exceedance Probability = 0.00143, MRI = 700 years). 8. The ASCE Wind Design Geodatabase can be accessed at the ASCE 7_Hazard Tool (https://asce7hazardtool.online) or approved equivalent. 					
F R301.2(3)	Design Criteria	ICC Approved for correlation reasons with ASCE 7-22	Increase See ICC RB 35-22	No	
<p>FIGURE R301.2(3)</p> <p>ALLOWABLE STRESS DESIGN GROUND SNOW LOADS, Pg (asd), FOR THE UNITED STATES (lb/ft²)</p> <p>For SI: 1 foot = 34.8 mm, 1 pound per square foot = 0.0479 kPa, 1 mile = 1.61 km.</p> <p>Notes:</p>					

2024 Code Section	TITLE OR SUBJECT	Reviewer Comments	Cost Yes/No	Amendment Needed Yes/No	TAG Comments/ Recommendation
<p>1. Location-specific ground snow load values are provided in the Ground Snow Load Geodatabase of geocoded design ground snow load values, which can be accessed at the ASCE 7_Hazard Tool at https://asce7hazardtool.online/ or an approved equivalent.</p> <p>2. Lines shown on the figure are contours separated by a constant ratio 1.18 with values of 10, 12, 14, 16, 19, 23, 27, 32, 38, 44, 52, 62, 73, 86, 101, 119 and 140 psf.</p> <p>3. Values denoted with a "+" symbol indicate design ground snow loads at state capitals or other high-population locations.</p> <p>4. Areas shown in gray represent areas with ground snow loads exceeding 140 psf. Ground snow load values for these locations can be determined from the Geodatabase.</p>					
T R301.2.1(1)	Design Criteria	ICC Approved for correlation reasons with ASCE 7-22	Increase See ICC RB 35-22	No	

2024 Code Section	TITLE OR SUBJECT	Reviewer Comments	Cost Yes/No	Amendment Needed Yes/No	TAG Comments/ Recommendation
-------------------	------------------	-------------------	-------------	-------------------------	------------------------------

2024 International Residential Code (IRC)

CHAPTER 3 BUILDING PLANNING

TABLE R301.2.1(1)

COMPONENT AND CLADDING LOADS FOR A BUILDING WITH A MEAN ROOF HEIGHT OF 30 FEET LOCATED IN EXPOSURE B (ASD) (psf) ^{a, b, c, d, e, f, g}

	ZO NE	EFFECTIVE WIND AREAS (square feet)	ULTIMATE DESIGN WIND SPEED, V_{ult}																									
			90.0		95.0		100.0		105.0		110.0		115.0		120.0		130.0		140.0		150.0		160.0		170.0		180.0	
			P os	Ne g	P os	Ne g	P os	Ne g	P os	Ne g	P os	Ne g	P os	Ne g	P os	Ne g	P os	Ne g	P os	Ne g	P os	Ne g	P os	Ne g	P os	Ne g	P os	Ne g
Gable roof 0 to 7 degrees	1, 1'	10	3.6	13.9	4.0	15.5	4.4	17.2	4.8	19.0	5.3	20.8	5.8	22.7	6.3	24.8	7.4	29.1	8.6	33.7	9.9	38.7	11.2	44.0	12.7	49.7	14.2	55.7
	1, 1'	20	3.3	12.4	3.7	13.8	4.1	15.3	4.5	16.8	5.0	18.5	5.4	20.2	5.9	22.0	7.0	25.8	8.1	29.9	9.3	34.4	10.5	39.1	11.9	44.1	13.3	49.5
	1, 1'	50	3.0	10.3	3.4	11.5	3.8	12.7	4.1	14.0	4.5	15.4	5.0	16.8	5.4	18.3	6.3	21.5	7.4	24.9	8.4	28.6	9.6	32.5	10.8	36.7	12.2	41.2
	1, 1'	100	2.8	8.7	3.1	9.7	3.5	10.8	3.8	11.9	4.2	13.1	4.6	14.3	5.0	15.5	5.9	18.2	6.8	21.2	7.8	24.3	8.9	27.6	10.0	31.2	11.3	35.0
	2	10	3.6	18.4	4.0	20.5	4.4	22.7	4.8	25.0	5.3	27.4	5.8	30.0	6.3	32.7	7.4	38.3	8.6	44.5	9.9	51.0	11.2	58.1	12.7	65.6	14.2	73.5
	2	20	3.3	16.4	3.7	18.2	4.1	20.2	4.5	22.3	5.0	24.5	5.4	26.7	5.9	29.1	7.0	34.2	8.1	39.6	9.3	45.5	10.5	51.8	11.9	58.4	13.3	65.5
	2	50	3.0	13.7	3.4	15.3	3.8	16.9	4.1	18.7	4.5	20.5	5.0	22.4	5.4	24.4	6.3	28.6	7.4	33.2	8.4	38.1	9.6	43.3	10.8	48.9	12.2	54.8
	2	100	2.8	11.7	3.1	13.0	3.5	14.5	3.8	15.9	4.2	17.5	4.6	19.1	5.0	20.8	5.9	24.4	6.8	28.3	7.8	32.5	8.9	37.0	10.0	41.8	11.3	46.8
	3	10	3.6	25.0	4.0	27.9	4.4	30.9	4.8	34.1	5.3	37.4	5.8	40.9	6.3	44.5	7.4	52.2	8.6	60.6	9.9	69.6	11.2	79.1	12.7	89.4	14.2	100.2
	3	20	3.3	21.0	3.7	23.4	4.1	26.0	4.5	28.6	5.0	31.4	5.4	34.4	5.9	37.4	7.0	43.9	8.1	50.9	9.3	58.4	10.5	66.5	11.9	75.1	13.3	84.2
	3	50	3.0	15.7	3.4	17.5	3.8	19.4	4.1	21.4	4.5	23.5	5.0	25.6	5.4	27.9	6.3	32.8	7.4	38.0	8.4	43.6	9.6	49.6	10.8	56.0	12.2	62.8
	3	100	2.8	11.7	3.1	13.0	3.5	14.5	3.8	15.9	4.2	17.5	4.6	19.1	5.0	20.8	5.9	24.4	6.8	28.3	7.8	32.5	8.9	37.0	10.0	41.8	11.3	46.8

2024 Code Section	TITLE OR SUBJECT	Reviewer Comments	Cost Yes/No	Amendment Needed Yes/No	TAG Comments/ Recommendation	
Gable roof > 20 to 27 degrees	1	20	5.3 -11.2 5.9 12.5 6.5 13.9 7.2 15.3 7.9 16.8 8.6 -18.4 9.4 20.0 11.0 23.5 12.7 -27.2 14.6 31.2 16.6 35.5 18.8 40.1 21.1 -45.0			
	1	50	4.6 -9.7 5.1 10.8 5.7 -11.9 6.2 13.1 6.8 14.4 7.5 15.8 8.2 17.2 9.6 20.2 11.1 23.4 12.7 26.8 14.5 30.5 16.4 34.5 18.3 -38.6			
	1	100	4.1 -8.5 4.5 -9.4 5.0 10.4 5.5 11.5 6.1 12.6 6.6 13.8 7.2 15.0 8.5 17.7 9.8 20.5 11.3 23.5 12.9 26.7 14.5 30.2 16.3 33.8			
	2	10	5.8 -19.9 6.4 22.1 7.1 24.5 7.9 27.0 8.6 29.7 9.4 32.4 10.3 35.3 12.1 41.4 14.0 48.0 16.1 55.2 18.3 62.8 20.6 70.8 23.1 79.4			
	2	20	5.3 -17.0 5.9 18.9 6.5 20.9 7.2 23.1 7.9 25.3 8.6 27.7 9.4 30.1 11.0 35.4 12.7 41.0 14.6 47.1 16.6 53.6 18.8 60.5 21.1 67.8			
	2	50	4.6 -13.1 5.1 14.6 5.7 16.2 6.2 17.9 6.8 19.6 7.5 21.4 8.2 23.3 9.6 27.4 11.1 31.8 12.7 36.5 14.5 41.5 16.4 46.8 18.3 52.5			
	2	100	4.1 -10.2 4.5 11.4 5.0 12.6 5.5 13.9 6.1 15.3 6.6 16.7 7.2 18.2 8.5 21.3 9.8 24.7 11.3 28.4 12.9 32.3 14.5 36.5 16.3 40.5			
	3	10	5.8 23.6 6.4 26.3 7.1 29.1 7.9 32.1 8.6 35.2 9.4 38.5 10.3 41.9 12.1 49.2 14.0 57.0 16.1 65.4 18.3 74.5 20.6 84.1 23.1 94.2			
	3	20	5.3 -20.0 5.9 22.3 6.5 24.7 7.2 27.2 7.9 29.9 8.6 32.6 9.4 35.5 11.0 41.7 12.7 48.4 14.6 55.5 16.6 63.2 18.8 71.3 21.1 80.0			
	3	50	4.6 -15.3 5.1 17.0 5.7 18.9 6.2 20.8 6.8 22.8 7.5 24.9 8.2 27.2 9.6 31.9 11.1 37.0 12.7 42.7 14.5 48.3 16.4 54.5 18.3 61.1			
	3	100	4.1 -11.7 4.5 13.0 5.0 -14.5 5.5 -15.9 6.1 -17.5 6.6 -19.1 7.2 -20.8 8.5 -24.4 9.8 -28.8 11.3 -32.3 12.9 -37.5 14.5 -41.8 16.3 -46.8			

2024 Code Section		TITLE OR SUBJECT	Reviewer Comments												Cost Yes/No				Amendment Needed Yes/No				TAG Comments/ Recommendation							
Gable roof > 27 to 45 degrees	1	10	8.0	-14.7	8.9	-16.3	9.9	-18.1	10.9	-20.0	12.0	-21.9	13.1	-24.0	14.2	-26.1	16.7	-30.6	19.4	-35.5	22.8	-40.8	25.3	-46.4	28.5	-52.3	32.0	-58.7		
	1	20	7.3	-12.4	8.2	-13.9	9.0	-15.4	10.0	-16.9	10.9	-18.6	11.9	-20.3	13.0	-22.1	15.3	-26.0	17.7	-30.1	20.3	-34.6	23.1	-39.3	26.4	-44.4	29.3	-49.8		
	1	50	6.4	-9.5	7.1	-10.6	7.9	-11.7	8.7	-12.9	9.6	-14.2	10.5	-15.5	11.4	-16.9	13.4	-19.8	15.5	-23.0	17.8	-26.4	20.3	-30.0	22.9	-33.9	25.6	-38.0		
	1	100	5.7	-7.3	6.4	-8.1	7.1	-9.0	7.8	-9.9	8.6	-10.8	9.3	-11.9	10.2	-12.9	11.9	-15.1	13.9	-17.6	15.9	-20.2	18.1	-22.9	20.4	-25.9	22.9	-29.0		
	2	10	8.0	-16.2	8.9	-18.0	9.9	-19.9	10.9	-22.0	12.0	-24.1	13.1	-26.4	14.2	-28.7	16.7	-33.7	19.4	-39.1	22.2	-44.9	25.3	-51.0	28.5	-57.6	32.0	-64.6		
	2	20	7.3	-14.4	8.2	-16.1	9.0	-17.8	10.0	-19.7	10.9	-21.6	11.9	-23.6	13.0	-25.7	15.3	-30.1	17.7	-34.9	20.3	-40.1	23.1	-45.6	26.4	-51.5	29.3	-57.7		
	2	50	6.4	-12.2	7.1	-13.6	7.9	-15.0	8.7	-16.6	9.6	-18.2	10.5	-19.9	11.4	-21.6	13.4	-25.4	15.5	-29.5	17.8	-33.8	20.3	-38.5	22.9	-43.4	25.6	-48.7		
	2	100	5.7	-10.5	6.4	-11.6	6.2	-12.9	7.8	-14.2	8.6	-15.6	9.3	-17.1	10.2	-18.6	11.9	-21.8	13.9	-25.3	15.9	-29.0	18.1	-33.0	20.4	-37.3	22.9	-41.8		
	3	10	8.0	-19.9	8.9	-22.1	9.9	-24.5	10.9	-27.0	12.0	-29.7	13.1	-32.4	14.2	-35.3	16.7	-41.4	19.4	-48.0	22.2	-55.2	25.3	-62.8	28.5	-70.8	32.0	-79.4		
	3	20	7.3	-17.3	8.2	-19.3	9.0	-21.3	10.0	-23.5	10.9	-25.8	11.9	-28.2	13.0	-30.7	15.3	-36.1	0.0	-41.8	20.3	-48.0	23.1	-54.6	26.4	-61.7	29.3	-69.1		
	3	50	6.4	-13.9	7.1	-15.5	7.9	-17.1	8.7	-18.9	9.6	-20.7	10.5	-22.7	11.4	-24.7	13.4	-29.4	15.5	-33.6	17.8	-38.6	20.3	-43.9	22.9	-49.5	25.6	-55.5		
	3	100	5.7	-11.3	6.4	-12.6	7.1	-14.0	7.8	-15.4	8.6	-16.9	9.3	-18.5	10.2	-20.1	11.9	-23.6	13.9	-27.4	15.9	-31.4	18.1	-35.8	20.4	-40.4	22.9	-45.3		

2024 Code Section		TITLE OR SUBJECT	Reviewer Comments													Cost Yes/No			Amendment Needed Yes/No			TAG Comments/ Recommendation								
	1	10	6.5	-	7.3	-	8.0	-	8.9	-	9.7	-	10.6	-	11.6	-	13.6	-	15.8	-	18.8	-	20.6	-	23.3	-	26.1	-	58.7	
	1	20	5.6	-	6.3	6.9	16.7	17.6	8.4	-19.4	9.2	21.2	10.0	23.0	11.7	-27.0	13.6	31.3	15.6	-36.0	17.8	40.9	20.1	-46.2	22.5	-	51.8			
	1	50	4.4	-10.7	5.0	-10.0	5.5	13.2	6.1	14.5	6.6	16.0	7.3	17.9	7.9	-19.0	9.3	22.3	10.8	25.9	12.4	-29.7	14.1	-33.8	15.9	-38.1	17.8	-	42.8	
	1	100	3.6	-9.0	4.0	-9.7	4.4	11.1	4.8	12.2	5.3	13.4	5.8	14.7	6.3	16.0	7.4	18.7	8.6	21.7	9.9	24.9	11.2	28.4	12.7	32.0	14.2	35.9		
	2	10	6.5	-	7.3	-	8.0	-	8.9	-	9.7	-	10.6	-	11.6	-	13.6	-	15.8	-	18.8	-	20.6	-	23.3	-	26.1	-	76.5	
Hipped roof > 7 to 20 degrees	2	20	5.6	-	6.3	6.9	19.2	21.3	7.7	23.5	8.4	25.7	9.2	28.1	10.0	30.6	11.7	35.9	13.6	41.7	15.6	47.9	17.8	54.5	20.1	61.5	22.5	68.9		
	2	50	4.4	-	5.0	16.4	5.5	18.2	6.1	20.1	6.6	22.0	7.3	24.1	7.9	26.2	9.3	30.7	10.8	35.7	12.4	40.9	14.1	46.6	15.9	52.6	17.8	58.9		
	2	100	3.6	-	4.0	14.3	4.4	15.9	4.8	17.5	5.3	19.2	5.8	21.0	6.3	22.8	7.4	26.8	8.6	31.1	9.9	35.7	11.2	40.6	12.7	45.9	14.2	51.4		
	3	10	6.5	-	7.3	-	8.0	-	8.9	-	9.7	-	10.6	-	11.6	-	13.6	-	15.8	-	18.8	-	20.6	-	23.3	-	26.1	-	82.4	
	3	20	5.6	-	6.3	6.9	20.9	22.9	7.7	25.2	8.4	27.7	9.2	30.3	10.0	33.0	11.7	38.7	13.6	44.9	15.6	51.5	17.8	58.6	20.1	66.2	22.5	74.2		
	3	50	4.4	-	5.0	17.6	5.5	19.5	6.1	21.5	6.6	23.6	7.3	25.8	7.9	28.1	9.3	33.0	10.8	38.3	12.4	43.9	14.1	-50.0	15.9	56.5	17.8	63.3		
	3	100	3.6	-	4.0	15.3	4.4	17.0	4.8	18.7	5.3	20.6	5.8	22.5	6.3	24.5	7.4	28.7	8.6	33.3	9.9	38.2	11.2	43.5	12.7	49.1	14.2	55.1		

2024 Code Section		TITLE OR SUBJECT	Reviewer Comments												Cost Yes/No				Amendment Needed Yes/No				TAG Comments/ Recommendation							
Hipped roof > 20 to 27 degrees	1	10	6.5	-11.7	7.3	-13.0	8.0	-14.5	8.9	-15.9	9.7	-17.5	10.6	-19.1	11.6	-20.8	13.6	-24.4	15.8	-28.3	18.1	-32.5	20.6	-37.0	23.3	-41.8	26.1	-46.8		
	1	20	5.6	-10.4	6.3	-11.6	6.9	-12.8	7.7	-14.1	8.4	-15.5	9.2	-16.9	10.0	-18.4	11.7	-21.6	13.6	-25.1	15.6	-28.8	17.8	-32.8	20.1	-37.0	22.5	-41.5		
	1	50	4.4	-8.6	5.0	-9.6	5.5	-10.6	6.1	-11.7	6.6	-12.8	7.3	-14.0	7.9	-15.3	9.3	-17.9	10.8	-20.8	12.4	-23.9	14.1	-27.2	15.9	-30.7	17.8	-34.4		
	1	100	3.6	-7.3	4.0	-8.1	4.4	-9.0	4.8	-9.9	5.3	-10.8	5.8	-11.9	6.3	-12.9	7.4	-15.1	8.6	-17.6	9.9	-20.2	11.2	-22.9	12.7	-25.9	14.2	-29.0		
	2	10	6.5	-16.2	7.3	-18.0	8.0	-19.9	8.9	-22.0	9.7	-24.1	10.6	-26.4	11.6	-28.7	13.6	-33.7	15.8	-39.1	18.1	-44.9	20.6	-51.0	23.3	-57.6	26.1	-64.6		
	2	20	5.6	-13.9	6.3	-15.5	6.9	-17.2	7.7	-18.9	8.4	-20.8	9.2	-22.7	10.0	-24.7	11.7	-29.0	13.6	-33.7	15.6	-38.7	17.8	-44.0	20.1	-49.7	22.5	-55.7		
	2	50	4.4	-11.0	5.0	-12.2	5.5	-13.5	6.1	-14.9	6.6	-16.4	7.3	-17.9	7.9	-19.5	9.3	-22.9	10.8	-26.6	12.4	-30.5	14.1	-34.7	15.9	-39.2	17.8	-43.9		
	2	100	3.6	-8.7	4.0	-9.7	4.4	-10.8	4.8	-11.9	5.3	-13.1	5.8	-14.3	6.3	-15.5	7.4	-18.2	8.6	-21.2	9.9	-24.3	11.2	-27.6	12.7	-31.2	14.2	-35.0		
	3	10	6.5	-16.2	7.3	-18.0	8.0	-19.9	8.9	-22.0	9.7	-24.1	10.6	-26.4	11.6	-28.7	13.6	-33.7	15.8	-39.1	18.1	-44.9	20.6	-51.0	23.3	-57.6	26.1	-64.6		
	3	20	5.6	-13.9	6.3	-15.5	6.9	-17.2	7.7	-18.9	8.4	-20.8	9.2	-22.7	10.0	-24.7	11.7	-29.0	13.6	-33.7	15.6	-38.7	17.8	-44.0	20.1	-49.7	22.5	-55.7		
	3	50	4.4	-11.0	5.0	-12.2	5.5	-13.5	6.1	-14.9	6.6	-16.4	7.3	-17.9	7.9	-19.5	9.3	-22.9	10.8	-26.6	12.4	-30.5	14.1	-34.7	15.9	-39.2	17.8	-43.9		
	3	100	3.6	-8.7	4.0	-9.7	4.4	-10.8	4.8	-11.9	5.3	-13.1	5.8	-14.3	6.3	-15.5	7.4	-18.2	8.6	-21.2	9.9	-24.3	11.2	-27.6	12.7	-31.2	14.2	-35.0		

2024 Code Section		TITLE OR SUBJECT	Reviewer Comments														Cost Yes/No				Amendment Needed Yes/No				TAG Comments/ Recommendation					
Hip Roof = 45 degrees	1	10	6.5	-12.4	7.3	-13.9	8.0	-15.4	8.9	-16.9	9.7	-18.6	10.6	-20.3	11.6	-22.1	13.6	-26.0	15.8	-30.1	18.1	-34.6	20.6	-39.3	23.3	-44.4	26.1	-49.8		
	1	20	5.4	-10.7	6.3	-11.9	6.9	-13.2	7.7	-14.5	8.4	-15.9	9.2	-17.4	10.0	-19.0	11.7	-22.2	13.6	-25.8	15.6	-29.6	17.8	-33.7	20.1	-38.0	22.5	-42.7		
	1	50	4.4	-8.3	5.0	-9.3	5.5	-10.3	6.1	-11.3	6.6	-12.4	7.3	-13.6	7.9	-14.8	9.3	-17.3	10.8	-20.1	12.4	-23.1	14.2	-26.2	15.9	-29.6	17.8	-33.2		
	1	100	3.6	-6.5	4.0	-7.3	4.4	-8.0	4.8	-8.9	5.3	-9.7	5.8	-10.6	6.3	-11.6	7.4	-13.6	8.6	-15.8	9.9	-18.1	11.2	-20.6	12.7	-23.3	14.2	-26.1		
	2	10	6.5	-14.7	7.3	-16.3	8.0	-18.1	8.9	-20.0	9.7	-21.9	10.6	-24.0	11.6	-26.1	13.6	-30.6	15.8	-35.5	18.1	-40.8	20.6	-46.4	23.3	-52.3	26.1	-58.7		
	2	20	5.6	-12.4	6.3	-13.9	6.9	-15.4	7.7	-16.9	8.4	-18.6	9.2	-20.3	10.0	-22.1	11.7	-26.0	13.6	-30.1	15.6	-34.6	17.8	-39.3	20.1	-44.4	22.5	-49.8		
	2	50	4.4	-9.5	5.0	-10.6	5.5	-11.7	6.1	-12.9	6.6	-14.2	7.3	-15.5	7.9	-16.9	9.3	-19.8	10.8	-23.0	12.4	-26.4	14.1	-30.0	15.9	-33.9	17.8	-38.0		
	2	100	3.6	-7.3	4.0	-8.1	4.4	-9.0	4.8	-9.9	5.3	-10.8	5.8	-11.9	6.3	-12.9	7.4	-15.1	8.6	-17.6	9.9	-20.2	11.2	-22.9	12.7	-25.9	14.2	-29.0		
	3	10	6.5	-19.1	7.3	-21.3	8.0	-23.6	8.9	-26.0	9.7	-28.6	10.6	-31.2	11.6	-34.0	13.6	-39.9	15.8	-46.3	18.1	-53.1	20.6	-60.4	23.3	-68.2	26.1	-76.5		
	3	20	5.6	-16.0	6.3	-17.8	6.9	-19.7	7.7	-21.8	8.4	-24.5	9.2	-27.6	10.0	-30.7	11.7	-35.4	13.6	-41.1	15.6	-48.8	17.8	-57.5	20.1	-66.7	22.5	-75.0		

2024 Code Section	TITLE OR SUBJECT	Reviewer Comments	Cost Yes/No	Amendment Needed Yes/No	TAG Comments/ Recommendation	
Walls	3	50	4.4 11.9 5.0 13.2 5.5 -14.6 6.1 16.1 6.6 17.7 7.3 -19.4 7.9 -21.1 9.3 -24.8 10.8 28.7 12.4 33.0 14.1 -37.5 15.9 -42.3 17.8 -47.5			
	3	100	3.6 8.7 4.0 9.7 4.4 10.8 4.8 11.9 5.3 13.1 5.8 14.3 6.3 15.5 7.4 18.2 8.6 21.2 9.9 24.3 11.2 27.6 12.7 31.2 14.2 35.0			
	4	10	8.7 9.5 9.7 10.6 10.8 11.7 11.9 12.9 13.1 14.2 14.3 15.5 16.9 18.2 19.8 21.2 22.9 24.3 26.3 27.6 30.0 31.2 33.8 35.0 37.9			
	4	20	8.3 9.1 9.3 10.1 10.3 11.2 11.4 12.4 12.5 13.6 13.8 14.8 16.2 17.4 19.0 20.2 22.0 23.3 25.4 26.7 28.7 29.8 32.4 33.4 36.4			
	4	50	7.8 8.6 8.7 9.5 9.7 10.6 10.7 11.7 11.7 12.8 12.8 14.0 15.3 16.3 17.9 18.9 20.7 21.7 23.8 24.7 27.1 27.9 30.6 31.3 34.3			
	4	100	7.4 8.2 8.3 9.1 9.2 10.1 10.1 11.1 11.1 12.2 12.1 13.3 14.5 15.5 17.1 18.0 19.8 20.7 22.7 23.5 25.8 26.5 29.2 29.7 32.7			
	5	10	8.7 11.7 9.7 13.0 10.8 14.5 11.9 15.9 13.1 17.5 14.3 19.1 15.5 20.8 18.2 24.4 21.2 28.3 24.3 32.5 27.6 37.0 31.2 41.8 35.0 46.8			
	5	20	8.3 10.9 9.3 12.2 10.3 13.5 11.4 14.9 12.5 16.3 13.8 17.8 14.8 19.4 17.4 22.8 20.4 26.4 23.3 30.4 26.4 34.5 29.8 39.0 33.4 43.7			
	5	50	7.8 9.9 8.7 11.0 9.7 12.2 10.7 13.4 11.7 14.8 12.8 16.1 13.9 17.6 16.3 20.6 18.9 23.9 21.7 27.4 24.7 31.2 27.9 35.2 31.3 39.5			
	5	100	7.4 9.1 8.3 10.1 9.2 11.2 10.1 12.1 11.1 13.6 12.1 14.8 13.2 16.5 15.0 19.0 18.0 22.0 20.7 25.2 23.5 28.7 26.5 32.4 29.7 36.4			

- For SI: 1 foot = 304.8 mm, 1 square foot = 0.0929 m², 1 mile per hour = 0.447 m/s, 1 pound per square foot = 0.0479 kPa.
- The effective wind area shall be equal to the span length multiplied by an effective width. This width shall be not less than one-third the span length. For cladding fasteners, the effective wind areas shall not be greater than the area that is tributary to an individual fastener.
 - For effective areas between those given, the load shall be interpolated or the load associated with the lower effective areas shall be used.
 - Table values shall be adjusted for height and exposure by multiplying by the adjustment coefficient in Table R301.2.1(2).
 - See Figure R301.2.1 for locations of zones.
 - Plus and minus signs signify pressures acting toward and away from the building surfaces.
 - Positive and negative design wind pressures shall not be less than 10 psf.
 - Roof overhang loads shall be determined by summing the applicable roof zone pressure with the adjacent wall zone pressure.

2024 Code Section	TITLE OR SUBJECT	Reviewer Comments	Cost Yes/No	Amendment Needed Yes/No	TAG Comments/ Recommendation
T R301.2.1(2)	Design Criteria	ICC Approved for correlation reasons with ASCE 7-22	Increase See ICC RB 35-22	No	

TABLE R301.2.1(2)
HEIGHT AND EXPOSURE ADJUSTMENT COEFFICIENTS FOR [Table R301.2.1\(1\)](#)

MEAN ROOF HEIGHT	EXPOSURE		
	B	C	D
15	0.82	1.21	1.47
20	0.89	1.29	1.55
25	0.94	1.35	1.61
30	1.00	1.40	1.66
35	1.05	1.45	1.70
40	1.06	1.49	1.74
45	1.10	1.53	1.78
50	1.13	1.56	1.81
55	1.16	1.59	1.84
60	1.19	1.62	1.87

R301.2.2	Design Criteria		No	NO	
----------	-----------------	--	----	----	--

R301.2.2 Seismic provisions. INSIGHTS

Buildings [within the scope of this code as defined in Section R101.2](#) shall be constructed in accordance with the requirements of this section and other seismic requirements of this code. The seismic provisions of this code shall apply as follows:

1. Townhouses [and buildings as permitted by the exceptions to Section R101.2 containing three or more dwelling units](#) in Seismic Design Categories C, Do, D 1 and D2.
2. Detached one- and two-family dwellings [and buildings as permitted by the exceptions to Section R101.2 containing less than three dwelling units](#) in Seismic Design Categories Do, D 1 and D2.

Buildings in Seismic Design Category E shall be designed to resist seismic loads in accordance with the International Building Code, except where the seismic design categories are reclassified to lower seismic design categories in accordance with Section R301.2.2.1. Components of buildings not required to be designed to resist seismic loads shall be constructed in accordance with the provisions of this code.

2024 Code Section	TITLE OR SUBJECT	Reviewer Comments	Cost Yes/No	Amendment Needed Yes/No	TAG Comments/ Recommendation
R301.2.2.1	Design Criteria		Increase See ICC RB164-22	NO	Include Seismic Map for WA
<p>R301.2.2.1 Determination of seismic design category.</p> <p>INSIGHTS</p> <p>Buildings shall be assigned a seismic design category in accordance with Figures R301.2.2.1(1) through R301.2.2.1(7), except as otherwise required by Section R401.4.</p>					
F R301.2.2.1(1)	Design Criteria		Increase See ICC RB32-22	NO	Include Seismic Map for WA
<p>FIGURE R301.2.2.1(1)</p> <p>SEISMIC DESIGN CATEGORIES FOR DEFAULT SITE CONDITIONS FOR THE CONTERMINOUS UNITED STATES(WESTERN)^a</p> <p>a. The seismic design categories and corresponding short-period design spectral response accelerations, S_{DS}, shown in Figures R301.2.2.1(1) through R301.2.2.1(7), are based on the default site class as defined in Chapter 11 of ASCE 7.</p>					
R301.2.2.10	Design Criteria	Repeal Existing Amendment	Increase, See ICC RB39-22	NO	New Section expands requirements to more than just water heaters and the WA Amendment is no longer needed.

2024 Code Section	TITLE OR SUBJECT	Reviewer Comments	Cost Yes/No	Amendment Needed Yes/No	TAG Comments/ Recommendation
R301.2.2.10 Anchorage of water heaters.	In Seismic Design Categories D₀, D₁ and D₂, and in townhouses in Seismic Design Category C, water heaters and thermal storage units shall be anchored against movement and overturning in accordance with Section M1307.2 or P2801.8				
R301.2.2.10.1	Design Criteria		Increase, See ICC RB39-22	NO	
R301.2.2.10.1	Seismic restraint resistance.				
R301.2.3	Design Criteria		Increase, See ICC RB34-22	NO	
R301.2.3	Snow loads.				

2024 Code Section	TITLE OR SUBJECT	Reviewer Comments	Cost Yes/No	Amendment Needed Yes/No	TAG Comments/ Recommendation
<p>construction, and structural insulated panel construction in regions with allowable stress design ground snow loads, $P_{g(ASD)}$, 70 pounds per square foot (3.35 kPa) or less, shall be in accordance with Chapters 5, 6 and 8. Buildings in regions with allowable stress design ground snow loads, $P_{g(ASD)}$, greater than 70 pounds per square foot (3.35 kPa) shall be designed in accordance with accepted engineering practice.</p>					
R301.2.4	Design Criteria		No	NO	
<p>R301.2.4 Floodplain construction. Buildings and structures constructed in whole or in part in flood hazard areas including A or V Zones) as established in Table R301.2, and substantial improvement and <i>repair</i> of substantial damage of buildings and structures located in whole or in part in flood hazard areas, shall be designed and constructed in accordance with Section R322. Buildings and structures that are located in more than one flood hazard area, including A Zones, Coastal A Zones, and V Zones, shall comply with the provisions associated with the most restrictive flood hazard area. Buildings and structures located in whole or in part in identified floodways shall be designed and constructed in accordance with ASCE 24.</p>					
R302.1	Fire Resistant Construction		No	NO	
<p>R302.1 Exterior walls. Construction, projections, openings and penetrations of exterior walls of dwellings, townhouses and accessory buildings shall comply with Table R302.1(1) based on fire separation distance ; or dwellings and townhouses equipped throughout with an automatic sprinkler system installed in accordance with Section P2904 shall comply with Table R302.1(2) based on fire separation distance. For the purposes of determining fire separation distance, dwellings and townhouses on the same lot shall be assumed to have an imaginary line between them. Where a new dwelling or townhouse is to be erected on the same lot as an existing dwelling or townhouse, the location of the assumed imaginary line with relation to the existing dwelling or townhouse shall be such that the existing dwelling or townhouse meets requirements of this section. Where a lot line exists between adjacent townhouse units, fire separation distance of exterior walls shall be measured to the lot line. Where a lot line does not exist between adjacent townhouse units, an imaginary line shall be assumed between the adjacent townhouse units and fire separation distance of exterior walls shall be measured to the imaginary line. Fire separation distance and requirements of Section R302.1 shall not apply to walls separating townhouse units that are required by Section R302.2. Exceptions: 1. Walls, projections, openings or penetrations in walls perpendicular to the line used to determine the fire separation distance. 2. Walls of individual dwelling units and their accessory buildings located on the same lot.</p>					

2024 Code Section	TITLE OR SUBJECT	Reviewer Comments	Cost Yes/No	Amendment Needed Yes/No	TAG Comments/ Recommendation
		<p>3. Detached tool sheds and storage sheds, playhouses and similar structures exempted from permits are not required to provide wall protection based on location on the lot. Projections beyond the exterior wall shall not extend over the lot line.</p> <p>4. Detached garages accessory to a dwelling unit located within 2 feet (610 mm) of a lot line are permitted to have roof eave projections not exceeding 4 inches (102 mm).</p> <p>5. Foundation vents installed in compliance with this code are permitted.</p>			
R302.3	Fire Resistant Construction	See Existing Amendment and Modify. Red Text Suggested	No	YES	Look at all of 302.3 with Mariko proposal
<p>R302.3 Two-family dwellings.</p> <p><i>Dwelling units in two-family dwellings shall be separated from each other in accordance with Sections 302.3.1 through 302.3.5.; regardless of whether a lot line exists between two dwelling units. One accessory dwelling unit constructed within an existing dwelling unit need not be considered a separated dwelling unit in a two-family dwelling where all required smoke alarms, in the accessory dwelling unit and the primary dwelling unit, are interconnected in such a manner that the actuation of one alarm will activate all alarms in both the primary dwelling unit and the accessory dwelling unit.</i></p>					
R302.3.1	Fire Resistant Construction		No	NO	Look at all of 302.3 with Mariko proposal
<p>R302.3.1 Dwelling unit separation.</p> <p><i>The two dwelling units shall be separated by fire-resistance rated assemblies that are vertical, horizontal, or a combination thereof.</i></p>					
R302.3.2	Fire Resistant Construction	Incorporate Amendment From 2021 R302.3 here. Red Text suggested	No	YES	Look at all of 302.3 with Mariko proposal
<p>R302.3.2 Fire-resistance rating.</p> <p><i>Vertical and horizontal assemblies separating dwelling units shall have a fire-resistance rating of 1 hour, or a fire-resistance rating of one-half hour in buildings equipped throughout with an automatic sprinkler system installed in accordance with Section P2904. Fire-resistance ratings shall be based on testing in accordance with ASTM E119 or UL 263, or an analytical method in accordance with Section 703.2.2 of the International Building Code. Where an accessory dwelling unit is added within an existing single-family residence to create a two-family dwelling, fire-rated separation between the accessory dwelling unit and the primary dwelling unit is not required when all required smoke alarms are interconnected in such a manner that the actuation of one alarm will activate all alarms in both the primary dwelling unit and the accessory dwelling unit.</i></p>					
R302.3.3	Fire Resistant Construction	Repeal Existing Amendment. New Model Language has same regulatory effect.	Decrease See ICC RB1-25	NO	Look at all of 302.3 with Mariko proposal

2024 Code Section	TITLE OR SUBJECT	Reviewer Comments	Cost Yes/No	Amendment Needed Yes/No	TAG Comments/ Recommendation
<p>R302.3.3 Continuity. Vertical and horizontal assemblies separating dwelling units shall be constructed in a manner that provides continuity of the fire-resistance rating between the dwelling units.</p>					
R302.3.3.2	Fire Resistant Construction	New Model Language Breaks Exception out From 2021 amendment to R302.3.2	Decrease See ICC RB1-25	NO	Look at all of 302.3 with Mariko proposal
<p>R302.3.3.2 Vertical assemblies. Vertical assemblies separating dwelling units shall extend to and be tight against any combination of the following:</p> <ol style="list-style-type: none"> 1. The foundation. 2. A horizontal assembly complying with Section R302.3.3. 3. The underside of roof sheathing. 4. The ceiling beneath an uninhabitable attic, provided that the ceiling is constructed using not less than 5/8-inch (15.9 mm) Type X gypsum board, an attic draft stop constructed as specified in Section R302.12.1 is provided above and along the vertical assembly terminating at the ceiling, and the structural framing supporting the ceiling is protected by not less than 1/2-inch (12.7 mm) gypsum board or equivalent. 					
R302.3.4	Fire Resistant Construction	Repeal Existing Amendment. New Model Language has same regulatory Effect as Existing Amendment	Decrease See ICC RB1-25	NO	Look at all of 302.3 with Mariko proposal
<p>R302.3.4 Supporting construction. Vertical and horizontal assemblies separating dwelling units shall be supported by construction having an equal or greater fire-resistance rating.</p>					

2024 Code Section	TITLE OR SUBJECT	Reviewer Comments	Cost Yes/No	Amendment Needed Yes/No	TAG Comments/ Recommendation
R302.3.5	Fire Resistant Construction	New Model Language	Decrease See ICC RB1-25	NO	Look at all of 302.3 with Mariko proposal
<p>R302.3.5 Vertically stacked dwelling units. Where one dwelling unit in a two-family dwelling is located above the other and an automatic sprinkler system complying with Section P2904 is not provided in both dwelling units, both of the following shall apply:</p> <ol style="list-style-type: none"> 1. Horizontal and vertical assemblies separating the dwelling units, including an interior stairway serving as the means of egress for the upper dwelling unit, shall be constructed in a manner that limits the transfer of smoke. 2. A notification appliance connected to smoke alarms in the other dwelling unit shall be provided in each dwelling unit. 					
R302.3.6	Fire Resistant Construction	Repeal Existing Amendment. New Model Language same as 2021 Amendment	No	NO	Look at all of 302.3 with Mariko proposal
<p>R302.3.6 Shared accessory rooms. Shared accessory rooms shall be separated from each individual dwelling unit in accordance with Table R302.3.6. Openings between the shared accessory room and dwelling unit shall comply with Section R302.3.6.1. Attachment of gypsum board shall comply with Table R702.3.5.</p>					
T R302.3.6	Fire Resistant Construction	New Table	No, See ICC RB69-25	NO	Look at all of 302.3 with Mariko proposal

2024 Code Section	TITLE OR SUBJECT	Reviewer Comments	Cost Yes/No	Amendment Needed Yes/No	TAG Comments/ Recommendation								
<p>TABLE R302.3.6 DWELLING-SHARED ACCESSORY ROOM SEPARATION</p> <table border="1" data-bbox="220 347 1635 565"> <thead> <tr> <th data-bbox="220 347 926 386">SEPARATION</th> <th data-bbox="926 347 1635 386">MATERIAL</th> </tr> </thead> <tbody> <tr> <td data-bbox="220 386 926 456">From the dwelling units and attics</td> <td data-bbox="926 386 1635 456">Not less than 1/2-inch gypsum board or equivalent applied to the accessory room side wall</td> </tr> <tr> <td data-bbox="220 456 926 495">From habitable rooms above or below the shared accessory room</td> <td data-bbox="926 456 1635 495">Not less than 5/8-inch Type X gypsum board or equivalent</td> </tr> <tr> <td data-bbox="220 495 926 565">Structures supporting floor/ceiling assemblies used for separation required by this section</td> <td data-bbox="926 495 1635 565">Not less than 1/2-inch gypsum board or equivalent</td> </tr> </tbody> </table> <p data-bbox="220 581 1635 634">For SI: 1 inch = 25.4 mm.</p>						SEPARATION	MATERIAL	From the dwelling units and attics	Not less than 1/2-inch gypsum board or equivalent applied to the accessory room side wall	From habitable rooms above or below the shared accessory room	Not less than 5/8-inch Type X gypsum board or equivalent	Structures supporting floor/ceiling assemblies used for separation required by this section	Not less than 1/2-inch gypsum board or equivalent
SEPARATION	MATERIAL												
From the dwelling units and attics	Not less than 1/2-inch gypsum board or equivalent applied to the accessory room side wall												
From habitable rooms above or below the shared accessory room	Not less than 5/8-inch Type X gypsum board or equivalent												
Structures supporting floor/ceiling assemblies used for separation required by this section	Not less than 1/2-inch gypsum board or equivalent												
R302.3.6.1	Fire Resistant Construction	Repeal Existing Amendment. New Model Language has same Regulatory Effect.	No	NO	Look at all of 302.3 with Mariko proposal								
<p>R302.3.6.1 Opening protection. Openings from a shared accessory room or area directly into a room used for sleeping purposes shall not be permitted. Other openings between the shared accessory room or area and dwelling units shall be equipped with solid wood doors not less than 1 3/8 inches (35 mm) in thickness, solid or honeycomb core steel doors not less than 13/8 inches (35 mm) in thickness, or a fire door assembly with a 20-minute fire-protection rating, equipped with a self-closing or automatic-closing device.</p>													

2024 Code Section	TITLE OR SUBJECT	Reviewer Comments	Cost Yes/No	Amendment Needed Yes/No	TAG Comments/ Recommendation
R302.3.6.2	Fire Resistant Construction	Repeal Existing Amendment. New Model Language has same Regulatory Effect.	No	NO	Look at all of 302.3 with Mariko proposal
<p>R302.3.6.2 Duct penetration. Ducts penetrating the walls or ceilings separating the dwelling from the shared accessory room shall be constructed of sheet steel not less than No. 26 gage (0.48 mm) or other approved material and shall not have openings into the shared accessory room.</p>					
R302.3.6.3	Fire Resistant Construction	Repeal Existing Amendment. New Model Language has same Regulatory Effect.	No	NO	Look at all of 302.3 with Mariko proposal
<p>R302.3.6.3 Other penetrations. Penetrations through the walls, ceiling and floor-level separation required in Section R302.3.6 shall be protected as required by Section R302.11, Item 4.</p>					
R302.13 EX #5	Fire Resistant Construction	New Exception	Decrease, See RB77-25	NO	
<p>5. Wood floor assemblies less than 600 square feet (55.7 m2) within detached accessory structures with no habitable space above them.</p>					
R303.1.1	Foam Plastic	Foam Plastic Sections Moved From 316 to 303	No	NO	
<p>R303.1.1 Spray-applied foam plastic. Single- and multiple-component spray-applied foam plastic insulation shall comply with the provisions of Section R303 and ICC 1100.</p>					
R303.1.2	Foam Plastic		No	NO	
<p>R303.1.2 Insulating sheathing. Foam plastic materials used as insulating sheathing shall comply with the provisions of Section R303 and the material standards in Table R303.1.2.</p>					
T R303.1.2	Foam Plastic		No	NO	

2024 Code Section	TITLE OR SUBJECT	Reviewer Comments	Cost Yes/No	Amendment Needed Yes/No	TAG Comments/ Recommendation
TABLE R303.1.2 MATERIAL STANDARDS FOR FOAM PLASTIC INSULATING SHEATHING					
FOAM PLASTIC INSULATING SHEATHING			MATERIAL STANDARDS		
Expanded Polystyrene (EPS)			ASTM C578		
Extruded Polystyrene (XPS)			ASTM C578		
Polyisocyanurate			ASTM C1289		
R306.2.1	Flood Resistant Construction	Section moved from 322 to 306. allows wet floodproofed accessory structures and detached garages in flood hazard areas	Decrease, See RB137-22	NO	

2024 Code Section	TITLE OR SUBJECT	Reviewer Comments	Cost Yes/No	Amendment Needed Yes/No	TAG Comments/ Recommendation
R306.2.1	Elevation requirements.	<p>1. Buildings and structures in flood hazard areas, not including flood hazard areas designated as Coastal A Zones, shall have the lowest floors elevated to or above the base flood elevation plus 1 foot (305 mm), or the design flood elevation, whichever is higher.</p> <p>2. In areas of shallow flooding (AO Zones), buildings and structures shall have the lowest floor (including basement) elevated to a height above the highest adjacent grade of not less than the depth number specified in feet (mm) on the FIRM plus 1 foot (305 mm), or not less than 3 feet (915 mm) if a depth number is not specified.</p> <p>3. Basement floors that are below grade on all sides shall be elevated to or above base flood elevation plus 1 foot (305 mm), or the design flood elevation, whichever is higher.</p> <p>4. Attached garages and carports shall comply with one of the following:</p> <p>4.1. The floors shall be elevated to or above the elevations required in Item 1 or Item 2, as applicable.</p> <p>4.2. The floors shall be at or above grade on not less than one side. Where an attached garage or carport is enclosed by walls, the walls shall have flood openings that comply with Section R306.2.2 and the attached garage or carport shall be used only for parking, building access or storage.</p> <p>5. Detached accessory structures and detached garages shall comply with one of the following:</p> <p>5.1. The floors shall be elevated to or above the elevations required in Item 1 or Item 2, as applicable.</p> <p>5.2. Floors below the elevations required in Item 1 or 2, as applicable, must be:</p> <p>5.2.1. Used only for parking or storage.</p> <p>5.2.2. One story and not larger than 600 square feet (55.74 m2).</p> <p>5.2.3. Anchored to resist flotation, collapse or lateral movement resulting from design flood loads.</p> <p>5.2.4. Equipped with flood openings that comply with Section R306.2.2.</p> <p>5.2.5. Constructed of flood-damage-resistant materials that comply with Section R306.1.8. Have mechanical, plumbing and electrical systems, if applicable, that comply with Section R306.1.6.</p> <p>Exception: Enclosed areas below the elevation required in this section, including basements with floors that are not below grade on all sides, shall meet the requirements of Section R306.2.2.</p>			
R306.3.2	Flood Resistant Construction	Section moved from 322 to 306. allows wet floodproofed accessory structures and detached garages in flood hazard areas	Decrease, See RB137-22	NO	

2024 Code Section	TITLE OR SUBJECT	Reviewer Comments	Cost Yes/No	Amendment Needed Yes/No	TAG Comments/ Recommendation
	<p>R306.3.2 Elevation requirements.</p> <p>1. Buildings and structures erected within coastal high-hazard areas and Coastal A Zones, shall be elevated so that the bottom of the lowest horizontal structural members supporting the lowest floor, with the exception of piling, pile caps, columns, grade beams and bracing, is elevated to or above the base flood elevation plus 1 foot (305 mm) or the design flood elevation, whichever is higher. Where stem wall foundations are permitted in Coastal A Zones in accordance with Section R306.3.3, the bottom of the lowest horizontal structural member supporting the lowest floor is the top of the foundation wall, or top of the portion of the foundation wall, supporting the slab.</p> <p>2. Basement floors that are below grade on all sides are prohibited.</p> <p>3. Attached garages used only for parking, building access or storage, and carports shall comply with Item 1 or shall be at or above grade on not less than one side and, if enclosed with walls, such walls shall comply with Item 7.</p> <p>4. Detached accessory structures and detached garages shall comply with either of the following:</p> <p> 4.1. The bottom of the lowest horizontal structural member supporting the floors shall be elevated to or above the elevation required in Item 1.</p> <p> 4.2. Floors below the elevations required in Item 1 must be:</p> <p> 4.2.1. Used only for parking or storage.</p> <p> 4.2.2. One story and not larger than 100 square feet (9.29 m2).</p> <p> 4.2.3. Anchored to resist flotation, collapse or lateral movement resulting from design flood loads.</p> <p> 4.2.4. Constructed of flood damage-resistant materials that comply with Section R306.1.8.</p> <p> 4.2.5. Equipped with mechanical, plumbing and electrical systems, if applicable, that comply with Section R306.1.6.</p> <p>5. The use of fill for structural support is prohibited.</p> <p>6. Minor grading, and the placement of minor quantities of fill, shall be permitted for landscaping and for drainage purposes under and around buildings and for support of parking slabs, pool decks, patios and walkways.</p> <p>7. Walls and partitions enclosing areas below the elevation required in this section shall meet the requirements of Sections R306.3.5 and R306.3.6.</p>				
R306.3.5	Flood Resistant Construction	elevator shafts do not require openings and breakaway	Decrease, See RB138-22	NO	

2024 Code Section	TITLE OR SUBJECT	Reviewer Comments	Cost Yes/No	Amendment Needed Yes/No	TAG Comments/ Recommendation
		walls, but the shafts must meet other requirements			
<p>R306.3.5 Walls below required elevation.</p> <p>Walls and partitions are permitted below the elevation required in Section R306.3.2, provided that such walls and partitions are not part of the structural support of the building or structure and:</p> <ol style="list-style-type: none"> 1. Electrical, mechanical and plumbing system components are not to be mounted on or penetrate through walls that are designed to break away under flood loads; and 2. Are constructed with insect screening or open lattice; or 3. Are designed to break away or collapse without causing collapse, displacement or other structural damage to the elevated portion of the building or supporting foundation system. Such walls, framing and connections shall have a resistance of not less than 10 (479 Pa) and not more than 20 pounds per square foot (958 Pa) as determined using allowable stress design, or a resistance to an ultimate load of not less than 17 and not more than 33 pounds per square foot (814 and 1580 Pa); or 4. Where wind loading values of this code exceed 20 pounds per square foot (958 Pa), as determined using allowable stress design or an ultimate load of 33 pounds per square foot (1580 Pa), the construction documents shall include documentation prepared and sealed by a registered design professional that: <ol style="list-style-type: none"> 4.1. The walls and partitions below the required elevation have been designed to collapse from a water load less than that which would occur during the base flood. 4.2. The elevated portion of the building and supporting foundation system have been designed to withstand the effects of wind and flood loads acting simultaneously on structural and nonstructural building components. Water-loading values used shall be those associated with the design flood. Wind-loading values shall be those required by this code. 5. Walls intended to break away under flood loads as specified in Item 3 or 4 have flood openings that meet the criteria in Section R306.2.2, Item 2. <p>Exceptions: The following shall not be required to comply with this section:</p> <ol style="list-style-type: none"> 1. Elevator shafts. 2. Utility chases that protect utility lines from freezing, provided that the utility chases are the minimum size necessary to protect the utility lines and do not provide access for a person to enter the space. 					
R310.3	Smoke Alarms	Adds Sleeping Lofts to location. See Existing Amendments Report.	No	Modify Existing Amendment R314.3	

2024 Code Section	TITLE OR SUBJECT	Reviewer Comments	Cost Yes/No	Amendment Needed Yes/No	TAG Comments/ Recommendation
<p>R310.3 Location. Smoke alarms shall be installed in the following locations:</p> <ol style="list-style-type: none"> 1. In each sleeping room. 2. Outside each separate sleeping area in the immediate vicinity of the bedrooms. 3. On each additional story of the dwelling unit, including basements and habitable attics and not including crawl spaces and uninhabitable attics. In dwelling units with split levels and without an intervening door between the adjacent levels, a smoke alarm installed on the upper level shall suffice for the adjacent lower level provided that the lower level is less than one full story below the upper level. 4. Not less than 3 feet (914 mm) horizontally from the door or opening of a bathroom that contains a bathtub or shower unless this would prevent placement of a smoke alarm required by this section. 5. In the hallway and in the room open to the hallway in dwelling units where the ceiling height of a room open to a hallway serving bedrooms exceeds that of the hallway by 24 inches (610 mm) or more. 6. Within the room to which a sleeping loft is open, in the immediate vicinity of the sleeping loft. 					
R310.3.1	Smoke Alarms	Correlates changes in IFC and aligns with current NFPA 72	No	NO	
<p>R310.3.1 Installation near cooking appliances. Smoke alarms shall be installed not less than 10 feet (3048 mm) horizontally from a permanently installed cooking appliance. Exception: Smoke alarms shall be permitted to be installed not less than 6 feet (1829 mm) horizontally from a permanently installed cooking appliance where necessary to comply with Section R310.3.</p>					
R313.1.2	Ceiling Height	New Section Clarifying addition to Ceiling Heights Section	No	NO	
<p>R313.1.2 Habitable attics and basements in existing buildings.</p>					

2024 Code Section	TITLE OR SUBJECT	Reviewer Comments	Cost Yes/No	Amendment Needed Yes/No	TAG Comments/ Recommendation
<p>Where a habitable attic or habitable space in a basement is created in an existing building, ceiling height shall not be less than 6 feet 8 inches (2032 mm). Bathrooms, toilet rooms and laundry rooms shall have a ceiling height of not less than 6 feet 4 inches (1930 mm). Exceptions:</p> <ol style="list-style-type: none"> 1. For rooms with sloped ceilings, the required floor area of the room shall have a ceiling height of not less than 5 feet (1524 mm) and not less than 50 percent of the required floor area shall have a ceiling height of not less than 6 feet 8 inches (2032 mm). 2. At beams, girders, ducts or other obstructions, the ceiling height shall be not less than 6 feet 4 inches (1930 mm) from the finished floor. 					
R314.1	Mezzanines	New Exception	No	NO	
<p>R314.1 General. Mezzanines shall comply with Sections R314.2 through R314.5. Exception: Sleeping lofts in dwelling units and sleeping units shall be permitted to comply with Section R315, subject to the limitations in Section R315.2.</p>					
R315.1	Sleeping Lofts	New Section to replace amendment in R333.1 See Existing Amendment Report	No	No Repeal Existing Amendment	
<p>R315.1 Sleeping lofts. Where provided in <i>dwelling units</i> or <i>sleeping units</i>, <i>sleeping lofts</i> shall comply with this code as modified by Sections R315.2 through R315.5. <i>Sleeping lofts</i> constructed in compliance with this section shall be considered a portion of the <i>story</i> below. Such <i>sleeping lofts</i> shall not contribute to the number of <i>stories</i> as regulated by this code. Exceptions: <i>Sleeping lofts</i> need not comply with Section R315 where they meet any of the following conditions:</p> <ol style="list-style-type: none"> 1. The <i>sleeping loft</i> has a depth of less than 3 feet (914 mm). 2. The <i>sleeping loft</i> has a floor area of less than 35 square feet (3.3 m²). 3. The <i>sleeping loft</i> is not provided with a permanent means of egress. 					
R315.2	Sleeping Lofts	New Section to replace amendment in R333.2 See Existing Amendment Report	No	NO Repeal Existing Amendment	

2024 Code Section	TITLE OR SUBJECT	Reviewer Comments	Cost Yes/No	Amendment Needed Yes/No	TAG Comments/ Recommendation
<p>R315.2 Sleeping loft limitations. <i>Sleeping lofts</i> shall comply with the following conditions: 1.The sleeping loft floor area shall be less than 70 square feet (6.5 m²). 2.The sleeping loft <i>ceiling height</i> shall not exceed 7 feet (2134 mm) for more than one-half of the sleeping loft floor area.</p>					
R315.3	Sleeping Lofts	New Section to replace amendment in R333.23 See Existing Amendment Report	No	NO Repeal Existing Amendment	
<p>R315.3 Sleeping loft ceiling height. The clear height below the sleeping loft floor construction shall not be less than 7 feet (2134 mm). The <i>ceiling height</i> above the finished floor of the <i>sleeping loft</i> shall not be less than 3 feet (914 mm). Spaces adjacent to the <i>sleeping loft</i> with a sloped ceiling measuring less than 3 feet (914 mm) from the finished floor to the finished ceiling shall not contribute to the sleeping loft floor area.</p>					
R315.4	Sleeping Lofts	New Section to replace amendment in R333.4 See Existing Amendment Report	No	NO Repeal Existing Amendment	
<p>R315.4 Sleeping loft area. The aggregate area of all sleeping lofts and mezzanines within a room shall comply with Section R314.3. Exception: The area of a single sleeping loft located within a dwelling unit or sleeping unit equipped with an automatic sprinkler system in accordance with Section P2904 shall not be greater than two-thirds of the area of the room in which it is located, provided that no other sleeping lofts or mezzanines are open to the room in which the sleeping loft is located.</p>					
R315.5	Sleeping Lofts	New Section to replace amendment in R333.5 See Existing Amendment Report	No	NO Repeal Existing Amendment	
<p>R315.5 Permanent egress for sleeping lofts. A permanent means of egress shall be provided for <i>sleeping lofts</i>. The means of egress shall comply with Section R318 as modified by Sections R315.5.1 through R315.5.3.</p>					
R315.5.1	Sleeping Lofts	New Section to replace amendment in R333.5.1 See Existing Amendment Report	No	NO Repeal Existing Amendment	
<p>R315.5.1 Ceiling height at sleeping loft means of egress. A <i>ceiling height</i> of not less than 3 feet (914 mm) shall be provided for the entire width of the means of egress from the <i>sleeping loft</i>.</p>					
R315.5.2	Sleeping Lofts	New Section	No	NO	

2024 Code Section	TITLE OR SUBJECT	Reviewer Comments	Cost Yes/No	Amendment Needed Yes/No	TAG Comments/ Recommendation
R315.5.2 Stairways.					
<i>Stairways providing egress from sleeping lofts shall be permitted to comply with Sections R315.5.2.1 through R315.5.2.3.</i>					
R315.5.2.1	Sleeping Lofts	New Section	No	NO	
R315.5.2.1 Width.					
<i>Stairways providing egress from a sleeping loft shall not be less than 17 inches (432 mm) in clear width at or above the handrail. The width below the handrail shall be not less than 20 inches (508 mm).</i>					
R315.5.2.2	Sleeping Lofts	New Section	No	NO	
R315.5.2.2 Treads and risers.					
<i>Risers for stairs providing egress from a sleeping loft shall be not less than 7 inches (178 mm) and not more than 12 inches (305 mm) in height. Tread depth and riser height shall be calculated in accordance with one of the following formulas:</i>					
<ol style="list-style-type: none"> 1.The tread depth shall be 20 inches (508 mm) minus four-thirds of the riser height. 2.The riser height shall be 15 inches (381 mm) minus three-fourths of the tread depth. 					
R315.5.2.3	Sleeping Lofts	New Section	No	NO	
R315.5.2.3 Landings.					
<i>Landings at stairways providing egress from sleeping lofts shall comply with Section R318.7.6, except that the depth of landings in the direction of travel shall be not less than 24 inches (610 mm).</i>					
R315.5.3	Sleeping Lofts	New Section	No	NO	
R315.5.3 Ladders.					
<i>Ladders used as a means of egress from sleeping lofts shall comply with Sections R315.5.3.1 and R315.5.3.2.</i>					
R315.5.3.1	Sleeping Lofts	New Section	No	NO	
R315.5.3.1 Size and capacity.					
<i>Ladders providing egress from sleeping lofts shall have a rung width of not less than 12 inches (305 mm), and 10-inch (254 mm) to 14-inch (356 mm) spacing between rungs. Ladders shall be capable of supporting a 300-pound (136 kg) load on any rung. Rung spacing shall be uniform within ³/₈ inch (9.5 mm).</i>					
R315.5.3.2	Sleeping Lofts	New Section	No	NO	
R315.5.3.2 Incline.					
<i>Ladders shall be inclined at 70 to 80 degrees from horizontal.</i>					
R317.6	Electric Vehicle Charging Systems	New Section Incorporate Amendment from R309.6.1 here. See Existing Amendment Report	No	YES	Edited 7/29. Patrick/Quyen to work 2024 EV Section

2024 Code Section	TITLE OR SUBJECT	Reviewer Comments	Cost Yes/No	Amendment Needed Yes/No	TAG Comments/ Recommendation
<p>R317.6 Electric vehicle charging systems. Where provided, electric vehicle charging systems shall be installed in accordance with NFPA 70. Electric vehicle charging system equipment shall be <i>listed</i> and <i>labeled</i> in accordance with UL 2202. <i>Electric vehicle supply equipment</i> shall be <i>listed</i> and <i>labeled</i> in accordance with UL 2594.</p>					
R317.7	Automotive Lifts	New Section	No	NO	
<p>R317.7 Automotive Lifts. Where provided, automotive lifts shall be <i>listed</i> and <i>labeled</i> in accordance with ANSI/ALI ALCTV.</p>					
R317.7.1	Automotive Lifts	New Section	No	NO	
<p>R317.7.1 Installation. Automotive lifts shall be installed in accordance with ANSI/ALI ALCTV, the listing and the lift manufacturer's installation instructions. Automotive lifts shall not be installed within the <i>habitable space of a dwelling unit</i>.</p>					
R318.7.6 Ex#2	Means of Egress	New Exception	No	NO	
<p>2. At an enclosed garage, the top landing at the <i>stair</i> shall be permitted to be not more than 7³/₄ inches (197 mm) below the top of the threshold.</p>					
R318.7.6 Ex#4	Means of Egress	New Exception	No	NO	
<p>3. At exterior doors, a top landing is not required for an exterior stairway of not more than two risers, provided that the door does not swing over the <i>stairway</i>.</p>					
R318.7.6 Ex#4	Means of Egress	New Exception	Decrease, See RB108-22	NO	
<p>4. Exterior <i>stairways</i> to grade with three or fewer <i>risers</i> serving a deck, porch or patio shall have a bottom landing width of not less than 36 inches (914 mm), provided that the stairway is not the required access to grade serving the required egress door.</p>					
R318.7.9	Means of Egress	New Section	Decrease, See RB114-22	NO	
<p>R318.7.9 Stairways in existing buildings. Alterations to existing <i>stairs</i> shall not be required to comply with the requirements of this code where the existing space and construction does not allow a reduction in pitch or slope.</p>					

2024 Code Section	TITLE OR SUBJECT	Reviewer Comments	Cost Yes/No	Amendment Needed Yes/No	TAG Comments/ Recommendation
R319.1	Emergency Escape and Rescue Openings	Adds sleeping lofts to section and ICC 500 for Storm Shelters See Existing Amendment Report.	No	YES, Modify Existing	Correlate Emergency Roof Access Openings to this section R319
<p>R319.1 Emergency escape and rescue opening required. <i>Basements, habitable attics, the room to which a sleeping loft is open</i>, and every sleeping room shall have not less than one operable <i>emergency escape and rescue opening</i>. Where <i>basements</i> contain one or more sleeping rooms, an <i>emergency escape and rescue opening</i> shall be required in each sleeping room. <i>Emergency escape and rescue openings</i> shall open directly into a <i>public way</i>, or to a <i>yard</i> or <i>court</i> that opens to a <i>public way</i>.</p> <p>Exceptions:</p> <ol style="list-style-type: none"> 1. <i>Basements</i> used only to house mechanical <i>equipment</i> not exceeding a total floor area of 200 square feet (18.58 m²). 2. <i>Storm shelters constructed in accordance with ICC 500</i>. 3. Where the dwelling <i>unit</i> or <i>townhouse unit</i> is equipped with an automatic sprinkler system installed in accordance with Section P2904, sleeping rooms in <i>basements</i> shall not be required to have <i>emergency escape and rescue openings</i> provided that the <i>basement</i> has one of the following: <ol style="list-style-type: none"> 3.1. One means of egress complying with Section R318 and one <i>emergency escape and rescue opening</i>. 3.2. Two means of egress complying with Section R318. 4. A <i>yard</i> shall not be required to open directly into a <i>public way</i> where the <i>yard</i> opens to an unobstructed path from the <i>yard</i> to the <i>public way</i>. Such path shall have a width of not less than 36 inches (914 mm). 					
R319.5.1	Emergency Escape and Rescue Openings	New Section	No	NO	
<p>R319.5.1 Window opening control device and fall protection device height. <i>Window opening control devices or fall protection devices</i> shall be located at a height in accordance with Section R319.1.1 or at as low a height as the device can be installed within the existing clear opening.</p>					
R320.5	Handrails	Combines Handrail Sections from all Stairs and Ramps. Adds Maximum Space allowed at Handrail Returns	No	NO	
R320.5 Continuity.					

2024 Code Section	TITLE OR SUBJECT	Reviewer Comments	Cost Yes/No	Amendment Needed Yes/No	TAG Comments/ Recommendation
<p>Handrails shall be continuous for the full length of the <i>flight</i>, from a point directly above the <i>nosing</i> of the landing at the top of the flight to a point directly above the lowest <i>nosing</i> of the <i>flight</i>. Handrails where required for ramps shall be continuous for the full length of the ramp. A handrail end shall be returned continuous to itself or toward a wall, guard or walking surface. Handrail returns shall not form a gap more than 1/4 inch (6.4 mm) from the adjacent wall.</p> <p>Exceptions:</p> <ol style="list-style-type: none"> 1.Handrail continuity shall be permitted to be interrupted by a newel post at a turn in a <i>flight</i> with <i>winders</i>, at a landing, or over the lowest tread. 2.A volute, turnout or starting easing shall be allowed to terminate over the lowest tread. 					
R322.3	Accessibility	Makes Ch 11 of IBC applicable to Care Facilities listed in R101.2	No	NO	
<p>R322.3 Care facilities. Where care facilities are permitted to be constructed in accordance with Section R101.2, the portions of the dwelling used to operate a business providing care shall be accessible in accordance with Chapter 11 of the International Building Code.</p>					
R323.1.1	Elevators and Platform Lifts	New Section. Adds ASME and CSA Standards to alert builders to already existing standards	No	NO	
<p>R323.1.1 Private residence elevators. The design, construction and installation of private residence elevators installed within a residential unit or providing access to one individual dwelling unit shall conform to ASME A17.1/CSA B44, Section 5.3.</p>					
R323.1.1.1	Elevators and Platform Lifts	New Section. Adds ASME and CSA Standards to alert builders to already existing standards	No	NO	
<p>R323.1.1.1 Hoistway enclosures. Hoistway enclosures for private residence elevators shall comply with ASME A17.1/CSA B44, Requirement 5.3.1.1.</p>					

2024 Code Section	TITLE OR SUBJECT	Reviewer Comments	Cost Yes/No	Amendment Needed Yes/No	TAG Comments/ Recommendation
R323.1.1.2	Elevators and Platform Lifts	New Section. Adds ASME and CSA Standards to alert builders to already existing standards	No	NO	
<p>R323.1.1.2 Hoistway opening protection. Hoistway landing doors for private residence elevators shall comply with ASME A17.1/CSA B44, Requirements 5.3.1.8.1 through 5.3.1.8.3.</p>					
R325.1.1	Light, Ventilation and Heating	The requirements for natural light and ventilation are combined in Section R325. This modification splits the requirements into their own subsections with no intended technical changes.	No	YES	Edited 7/29 change recommendation from repeal existing to maintain.

2024 Code Section	TITLE OR SUBJECT	Reviewer Comments	Cost Yes/No	Amendment Needed Yes/No	TAG Comments/ Recommendation
		Contains Amendment Language			
<p>R325.1.1 Natural light. Habitable rooms shall have an aggregate area of glazed openings not less than 8 percent of the floor area of such rooms. Required glazed openings shall face directly onto a street, alley or <i>public way</i>, or a yard or <i>court</i> located on the same <i>lot</i> as the <i>building</i>.</p> <p>Exceptions:</p> <ol style="list-style-type: none"> 1. 1.Required glazed openings shall be permitted to face into a roofed porch, deck or patio adjacent to a street, alley, <i>public way</i>, yard or <i>court</i>, where there the longer side of the roofed area is not less than 65 percent unobstructed and the <i>ceiling height</i> is not less than 7 feet (2134 mm). 2. 2.Required glazed openings shall be permitted to face into a <i>sunroom</i> adjacent to a street, alley, <i>public way</i>, yard or <i>court</i>. 3. 3.Glazed openings are not required where artificial light is provided that is capable of producing an average illumination of 6 footcandles (65 lux) over the area of the room at a height of 30 inches (762 mm) above the floor level. 4. 4.Eave projections shall not be considered as obstructing the clear open space of a <i>yard</i> or <i>court</i>. 					
R325.1.2	Light, Ventilation and Heating	The requirements for natural light and ventilation are combined in Section R325. This modification splits the requirements into their own subsections with no intended technical changes.	No	NO	

2024 Code Section	TITLE OR SUBJECT	Reviewer Comments	Cost Yes/No	Amendment Needed Yes/No	TAG Comments/ Recommendation
		Contains Amendment Language			
<p>R325.1.2 Natural ventilation. Habitable rooms shall have an aggregate area openable to the outdoors not less than 4 percent of the floor area of such rooms. Openings shall be through windows, <i>skylights</i>, doors, louvers or other <i>approved</i> openings to the outdoor air. Such openings shall be provided with <i>ready access</i> or shall otherwise be readily controllable by the building occupants.</p> <p>Exceptions:</p> <ol style="list-style-type: none"> 1. 1.Natural <i>ventilation</i> shall not be required in habitable rooms other than <i>kitchens</i> where a whole-house mechanical <i>ventilation</i> system or a mechanical <i>ventilation</i> system capable of producing 0.35 air changes per hour in the habitable rooms is installed in accordance with Section M1505. 2. 2.Natural <i>ventilation</i> shall not be required in <i>kitchens</i> where a <i>local exhaust</i> system is installed in accordance with Section M1505. 3. 3.Required <i>ventilation</i> openings shall be permitted to open into a thermally isolated <i>sunroom</i> or roofed porch, deck, or patio where not less than 40 percent of the roofed area perimeter is open to the outdoor air. 4. 4.Required <i>ventilation</i> openings shall be permitted to open into a thermally isolated <i>sunroom</i> provided there is an openable area between the adjoining room and the sunroom of not less than one-tenth of the floor area of the interior room and not less than 20 square feet (1.9 m²). The minimum openable area of the <i>sunroom</i> to outdoor air shall be based on the total floor area of the adjoining room and the <i>sunroom</i>. 					
R329.3.1	Solar Energy Systems	Adds UL Standard for BIPVs	No	NO	
<p>R329.3.1 Equipment listings. <i>Photovoltaic panels</i> and modules shall be <i>listed</i> and <i>labeled</i> in accordance with UL 1703 or with both UL 61730-1 and UL 61730-2. Inverters shall be <i>listed</i> and <i>labeled</i> in accordance with UL 1741. Systems connected to the utility grid shall use inverters <i>listed</i> for utility interaction. Mounting systems <i>listed</i> and <i>labeled</i> in accordance with UL 2703 shall be installed in accordance with the manufacturer’s installation instructions and their listings. Building-integrated photovoltaic (BIPV) roof coverings and BIPV roof assemblies shall be listed and labeled in accordance with UL 7103.</p>					

2024 Code Section	TITLE OR SUBJECT	Reviewer Comments	Cost Yes/No	Amendment Needed Yes/No	TAG Comments/ Recommendation
R329.5.2	Solar Energy Systems	This recognizes other types of BIPV systems that are available for installation and does not limit to just roofing applications.	No	NO	
<p>R329.5.2 BIPV exterior wall coverings and fenestration. BIPV exterior wall coverings and fenestration shall comply with Section R705.</p>					
R329.6.4	Solar Energy Systems	Aligns with IFC and adds new standard	No	NO	
<p>R329.6.4 Building-integrated photovoltaic (BIPV) systems. Where building-integrated photovoltaic (BIPV) systems are installed in a manner creating areas with electrical hazards that are hidden from view, markings shall be provided to identify the hazardous areas to avoid for ladder placement. The markings shall be reflective and be visible from <i>grade</i> beneath the eaves or other location <i>approved</i> by the fire code official. Exception: BIPV systems <i>listed</i> in accordance with UL 3741, where the removal or cutting away of portions of the <i>BIPV system</i> during firefighting operations have been determined to not expose a firefighter to electrical shock hazards.</p>					
R329.7	Solar Energy Systems	Establishes appropriate fire testing and listing criteria for overhead PV support structures	No	NO	
<p>R329.7 Elevated photovoltaic (PV) support structures. Elevated <i>PV</i> support structures used as an <i>accessory structure</i> shall comply with either Section R329.7.1 or R329.7.2. Elevated <i>PV</i> support structures shall be considered a roof for the purposes of establishing the number of <i>stories</i> and fire separation distances.</p>					
R329.7.1	Solar Energy Systems	Establishes appropriate fire testing and listing criteria for overhead PV support structures	No	NO	
<p>R329.7.1 PV panels installed over open-grid framing or noncombustible deck. Elevated <i>PV</i> support structures with <i>PV</i> panels installed over open-grid framing or over a noncombustible deck shall have <i>PV</i> panels tested, listed and <i>labeled</i> with a fire type rating in accordance with UL 1703 or with both UL 61730-1 and UL 61730-2. <i>Photovoltaic panels</i> marked “not fire rated” shall not be installed on elevated <i>PV</i> support structures.</p>					

2024 Code Section	TITLE OR SUBJECT	Reviewer Comments	Cost Yes/No	Amendment Needed Yes/No	TAG Comments/ Recommendation
R329.7.2	Solar Energy Systems	Establishes appropriate fire testing and listing criteria for overhead PV support structures	No	NO	
<p>R329.7.2 PV panels installed over a roof assembly. Elevated PV support structures with a PV panel system installed over a <i>roof assembly</i> shall have a fire classification in accordance with Section R902.4.</p>					
R330.4 #4	Energy Storage Systems	To reduce the chance of fire spread and allow its occupants ample amount of time to evacuate the building the envelope must be sealed.	Increase See RB157-22	NO	
<p>4. Enclosed utility <i>closets, basements</i>, storage or utility spaces within <i>dwelling units</i> with finished or noncombustible walls and ceilings. Walls and ceilings of unfinished wood-framed construction shall be provided with not less than $\frac{5}{8}$-inch (15.9 mm) <i>Type X gypsum wallboard</i>. Openings into the dwelling shall be equipped with solid wood doors not less than $1\frac{3}{8}$ inches (35 mm) in thickness, solid or honeycomb-core steel doors not less than $1\frac{3}{8}$ inches (35 mm) in thickness, or doors with a 20-minute fire protection rating. Doors shall be self-latching and equipped with a self-closing or an automatic-closing device. Penetrations through the required <i>gypsum wallboard</i> into the dwelling shall be protected as required by Section R302.11, Item 4.</p>					
R330.8.1	Energy Storage Systems	Aligns with IFC changes. The intent is to provide clear methods for providing vehicle impact protection.	No	NO	
<p>R330.8.1 Garages. Where an ESS is installed in the normal driving path of vehicle travel within a garage, impact protection complying with Section R330.8.3 shall be provided. The normal driving path is a space between the garage vehicle opening and the interior face of the back wall to a height of 48 inches (1219 mm) above the finished floor. The width of the normal driving path shall be equal to the width of the</p>					

2024 Code Section	TITLE OR SUBJECT	Reviewer Comments	Cost Yes/No	Amendment Needed Yes/No	TAG Comments/ Recommendation
<p>garage door opening. Impact protection shall also be provided for an ESS installed at either of the following locations (see Figure R330.8.1):</p> <ol style="list-style-type: none"> 1. 1.On the interior face of the back wall and located within 36 inches (914 mm) to the left or to the right of the normal driving path. 2. 2.On the interior face of a side wall and located within 24 inches (610 mm) from the back wall and 36 inches (914 mm) of the normal driving path. <p>Exception:Where the clear height of the vehicle garage opening is 7 feet 6 inches (2286 mm) or less, ESS installed not less than 36 inches (914 mm) above finished floor are not subject to vehicle impact protection requirements.</p>					
R330.8.2	Energy Storage Systems	Aligns with IFC changes. The intent is to provide clear methods for providing vehicle impact protection.	No	NO	
<p>R330.8.2 Other locations subject to vehicle impact. Where an ESS is installed in a location other than as defined in Section R330.8.1 and is subject to vehicle damage, impact protection shall be provided in accordance with Section R330.8.3.</p>					
R330.8.3	Energy Storage Systems	Aligns with IFC changes. The intent is to provide clear methods for providing vehicle impact protection.	No	NO	

2024 Code Section	TITLE OR SUBJECT	Reviewer Comments	Cost Yes/No	Amendment Needed Yes/No	TAG Comments/ Recommendation
	<p>R330.8.3 Impact protection options.</p> <p>ESS protection shall comply with one of the following:</p> <ol style="list-style-type: none"> 1. Bollards constructed in accordance with one of the following: <ol style="list-style-type: none"> 1.1. Minimum 48 inches (1219 mm) in length by 3 inches (76 mm) in diameter Schedule 80 steel pipe embedded in a concrete pier not less than 12 inches (305 mm) deep and 6 inches (152 mm) in diameter, with not less than 36 inches (914 mm) of pipe exposed, filled with concrete and spaced at a maximum interval of 5 feet (1524 mm). Each bollard shall be located not less than 6 inches (152 mm) from an ESS. 1.2. Minimum 36 inches (914 mm) in height by 3 inches (76 mm) in diameter Schedule 80 steel pipe fully welded to a steel plate not less than 8 inches (203 mm) in length by 1/4 inch (6.4 mm) in thickness and bolted to a concrete floor by means of 4 1/2-inch (114 mm) concrete anchors imbedded not less than 3 inches (76 mm). Spacing shall be not greater than 60 inches (1524 mm), and each bollard shall be located not less than 6 inches (152 mm) from the ESS. 1.3. Premanufactured steel pipe bollards filled with concrete and anchored in accordance with the manufacturer's installation instructions, with spacing not greater than 60 inches (1524 mm). Each bollard shall be located not less than 6 inches (152 mm) from the ESS. 2. Wheel barriers constructed in accordance with one of the following: <ol style="list-style-type: none"> 2.1. Concrete or polymer 4 inches (102 mm) in height by 5 inches (127 mm) in width by 70 inches (1778 mm) in length, anchored to the concrete floor not less than every 36 inches (914 mm) and located not less than 54 inches (1372 mm) from the ESS. Concrete anchors not less than 3 1/2 inches (89 mm) in diameter with 3-inch (76 mm) embedment per barrier shall be used. Spacing between barriers shall be not greater than 36 inches (914 mm). 2.2. Premanufactured wheel barriers shall be anchored in accordance with the manufacturer's installation instructions. 3. An <i>approved</i> method designed to resist an impact of 2,000 pounds per square foot (95 760 N/m²) in the direction of travel at 24 inches (610 mm) above <i>grade</i>. 				

2024 Code Section	TITLE OR SUBJECT	Reviewer Comments	Cost Yes/No	Amendment Needed Yes/No	TAG Comments/ Recommendation
CHAPTER 4 FOUNDATIONS					
R401.4	General	For consistency with the IBC and ASCE 7, this proposal expands the already required geotechnical investigation to include determination of the Site Class and short-period spectral response acceleration	Increase, See RB164-22	NO	
<p>R401.4 Soil tests. Where quantifiable data created by accepted soil science methodologies indicate <i>expansive soils</i>, <i>compressible soils</i>, shifting soils or other questionable soil characteristics are likely to be present, the <i>building official</i> shall determine whether to require a soil test to determine the soil's characteristics at a particular location. This test shall be done by an <i>approved agency</i> using an <i>approved method</i>. Where the seismic design category in accordance with Section R301.2.2.1 is C or greater and where soil testing is performed, the geotechnical report shall include the determination of the site class and the short-period spectral response acceleration, S_{DS}, in accordance with Section 1613 of the <i>International Building Code</i>. The seismic design category shall be assigned in accordance with Table R301.2.2.1.1.</p>					
T R401.4.1(2)	General	A column is added providing U.S. Department of Agriculture (USDA) soil classifications in addition to the traditional Unified Soil Classification System	Increase, See RB165-22	NO	

TABLE R401.4.1(2)

PROPERTIES OF SOILS CLASSIFIED ACCORDING TO THE UNIFIED SOIL CLASSIFICATION SYSTEM

SOIL GROUP	UNIFIED SOIL CLASSIFICATION SYSTEM SYMBOL	SOIL DESCRIPTION	USDA TEXTURAL SOIL CLASSIFICATION	DRAINAGE CHARACTERISTICS ^a	FROST HEAVE POTENTIAL	VOLUME CHANGE POTENTIAL EXPANSION ^b
Group I	GW	Well-graded gravels, gravel sand mixtures, little or no fines	N/A	Good	Low	Low
	GP	Poorly graded gravels or gravel sand mixtures, little or no fines	N/A	Good	Low	Low
	SW	Well-graded sands, gravelly sands, little or no fines	N/A	Good	Low	Low
	SP	Poorly graded sands or gravelly sands, little or no fines	Sand	Good	Low	Low
	GM	Silty gravels, gravel-sand-silt mixtures	N/A	Good	Medium	Low
	SM	Silty sand, sand-silt mixtures	Loamy sand, sandy loam	Good	Medium	Low
Group II	GC	Clayey gravels, gravel-sand-clay mixtures	N/A	Medium	Medium	Low
	SC	Clayey sands, sand-clay mixture	Sandy clay loam, sandy clay	Medium	Medium	Low
	ML	Inorganic silts and very fine sands, rock flour, silty or clayey fine sands or clayey silts with slight plasticity	Silt, silt loam	Medium	High	Low
	CL	Inorganic clays of low to medium plasticity, gravelly clays, sandy clays, silty clays, lean clays	Loam, clay loam, silty clay loam	Medium	Medium	Medium to Low
Group III	CH	Inorganic clays of high plasticity, fat clays	Clay, silty clay	Poor ^c	Medium	High
	MH	Inorganic silts, micaceous or diatomaceous fine sandy or silty soils, elastic silts	N/A	Poor ^c	High	High
Group IV	OL	Organic silts and organic silty clays of low plasticity	N/A	Poor ^c	Medium	Medium
	OH	Organic clays of medium to high plasticity, organic silts	N/A	Unsatisfactory ^c	Medium	High
	Pt	Peat and other highly organic soils	N/A	Unsatisfactory ^c	Medium	High

For SI: 1 inch = 25.4 mm.

N/A = Not Applicable.

a. The percolation rate for good drainage is over 4 inches per hour, medium drainage is 2 inches to 4 inches per hour, and poor is less than 2 inches per hour.

b. Soils with a low potential expansion typically have a plasticity index (PI) of 0 to 15, soils with a medium potential expansion have a PI of 10 to 35 and soils with a high potential expansion have a PI greater than 20.

c. Unsuitable as backfill material.

2024 Code Section	TITLE OR SUBJECT	Reviewer Comments	Cost Yes/No	Amendment Needed Yes/No	TAG Comments/ Recommendation
R403.1.1	Footings	Allows Crushed stone footings provisions to also be used for masonry foundations and cast-in-place concrete foundations. See Existing Amendment Report	Decrease, See RB166-22	Modify Existing Amendment	
<p>R403.1.1 Minimum size.</p> <p>The minimum width, W, and thickness, T, for concrete footings shall be in accordance with Tables R403.1(1) through R403.1(3) and Figure R403.1(1) or R403.1.3, as applicable, but not less than 12 inches (305 mm) in width and 6 inches (152 mm) in depth. The footing width shall be based on the load-bearing value of the soil in accordance with Table R401.4.1(1). Footing projections, P, shall be not less than 2 inches (51 mm) and shall not exceed the thickness of the footing. Footing thickness and projection for fireplaces shall be in accordance with Section R1001.2. The size of footings supporting piers and columns shall be based on the tributary load and allowable soil pressure in accordance with Table R401.4.1(1). Footings for wood foundations shall be in accordance with the details set forth in Section R403.2, and Figures R403.1(2) and R403.1(3). Footings for precast foundations shall be in accordance with the details set forth in Section R403.4, Table R403.4, and Figures R403.4(1) and R403.4(2). Crushed stone footings for cast-in-place concrete foundations shall be in accordance with Section R403.5.</p>					

2024 Code Section	TITLE OR SUBJECT	Reviewer Comments	Cost Yes/No	Amendment Needed Yes/No	TAG Comments/ Recommendation
T R403.1.2	Footings	Provides editorial clarification of existing provisions for required footing locations	No	NO	

2024 Code Section	TITLE OR SUBJECT	Reviewer Comments	Cost Yes/No	Amendment Needed Yes/No	TAG Comments/ Recommendation
-------------------	------------------	-------------------	-------------	-------------------------	------------------------------

TABLE R403.1.2

CONTINUOUS FOOTING REQUIREMENTS IN SEISMIC DESIGN CATEGORIES D₀, D₁ AND D₂

BUILDING PLAN DIMENSIONS	1-STORY						2-STORY						3-STORY	
	50 feet or less			> 50 feet			50 feet or less			> 50 feet			Any	
SDC	D ₀	D ₁	D ₂	D ₀	D ₁	D ₂	D ₀	D ₁	D ₂	D ₀	D ₁	D ₂	D ₀	D ₁
Continuous footings supporting exterior walls	R	R	R	R	R	R	R	R	R	R	R	R	R	R
Continuous footings supporting required interior braced wall panels	NR	NR	NR	R ^a	R ^a	R ^a	NR	NR	R ^a	R ^a	R ^a	R ^a	R	R

For SI: 1 foot = 304.8 mm.

R = Continuous solid or fully grouted masonry or concrete footings in accordance with [Section R403.1.3.4](#) required.

NR = Continuous footings not required.

- a. Buildings shall be permitted to have interior braced wall panels supported on continuous foundations at intervals not exceeding 50 feet, provided that the following conditions are all met:
1. The height of cripple walls does not exceed 4 feet.
 2. First-floor braced wall panels are supported on doubled floor joists, continuous blocking or floor beams.
 3. The distance between bracing lines does not exceed twice the building width measured parallel to the braced wall line.

R403.5	Footings	Allows Crushed stone footings provisions to also be used for masonry	Decrease, See RB166-22	NO	
--------	----------	--	--	----	--

2024 Code Section	TITLE OR SUBJECT	Reviewer Comments	Cost Yes/No	Amendment Needed Yes/No	TAG Comments/ Recommendation
		foundations and cast-in-place concrete foundations.			

R403.5 Crushed stone footings for cast-in-place concrete foundations.

Crushed stone footings in accordance with [Section R403.4.1](#) shall be permitted for nonretaining cast-in-place concrete foundations complying with [Section R404.1.3](#) and this section. The footing and foundation wall shall be installed in accordance with [Figure R403.5\(1\)](#), or [Figure R403.5\(2\)](#) and [Table R403.5](#), or [Figure R403.5\(3\)](#). Crushed stone footings for cast-in-place concrete foundations shall be permitted for townhouses in *Seismic Design Categories A and B* and one- and two-family dwellings in *Seismic Design Categories A, B and C*.

F R403.5(1)	Footings	New Figure to go with R403.5	Decrease, See RB166-22	NO	
-------------	----------	------------------------------	--	----	--



For SI: 1 inch = 25.4 mm, 1 foot = 304.5 mm.

FIGURE R403.5(1)

CRUSHED STONE FOOTINGS FOR CAST-IN-PLACE CONCRETE FOUNDATIONS IN SEISMIC DESIGN CATEGORIES A, B, AND C AND WIND EXPOSURE CATEGORIES B, C, AND D: CAST-IN-PLACE CONCRETE FOUNDATION WALL WITH WOOD CRIPPLE WALL

2024 Code Section	TITLE OR SUBJECT	Reviewer Comments	Cost Yes/No	Amendment Needed Yes/No	TAG Comments/ Recommendation
F R403.5(2)	Footings	New Figure to go with R403.5	Decrease, See RB166-22	NO	

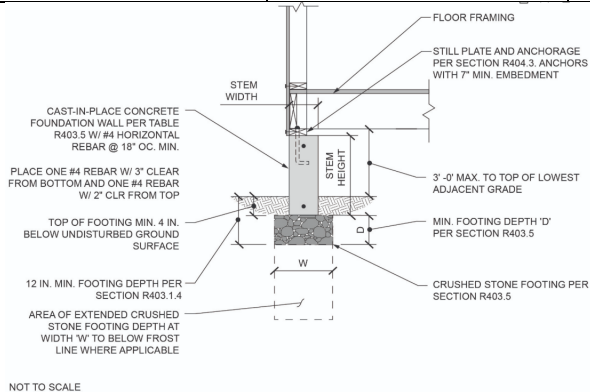

For SI: 1 inch = 25.4 mm, 1 foot = 304.5 mm.

FIGURE R403.5(2)

CRUSHED STONE FOOTINGS FOR CAST-IN-PLACE CONCRETE FOUNDATIONS IN SEISMIC DESIGN CATEGORIES A, B, AND C AND WIND EXPOSURE CATEGORIES B, C, AND D: CONCRETE SLAB-ON-GROUND WITH TURNED DOWN FOUNDATION CAST-IN-PLACE CONCRETE FOUNDATION WALL WITH NO CRIPPLE WALL ABOVE

F R403.5(3)	Footings	New Figure to go with R403.5	Decrease, See RB166-22	NO	
-------------	----------	------------------------------	---	----	--

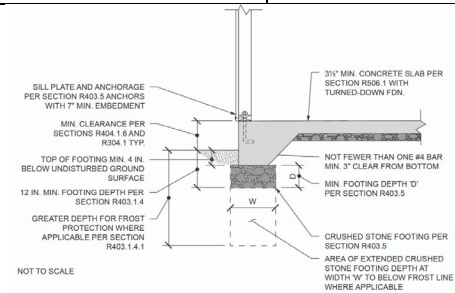

For SI: 1 inch = 25.4 mm, 1 foot = 304.5 mm.

FIGURE R403.5(3)

2024 Code Section	TITLE OR SUBJECT	Reviewer Comments	Cost Yes/No	Amendment Needed Yes/No	TAG Comments/ Recommendation
CRUSHED STONE FOOTINGS FOR CAST-IN-PLACE CONCRETE FOUNDATIONS IN SEISMIC DESIGN CATEGORIES A, B, AND C AND WIND EXPOSURE CATEGORIES B, C, AND D: CONCRETE SLAB-ON-GROUND WITH TURNED DOWN FOUNDATION					
T R403.5	Footings	Addresses the out-of-plane resistance concern raised by FEMA	Decrease, See RB166-22	NO	

2024 Code Section	TITLE OR SUBJECT	Reviewer Comments	Cost Yes/No	Amendment Needed Yes/No	TAG Comments/ Recommendation
-------------------	------------------	-------------------	-------------	-------------------------	------------------------------

TABLE R403.5

MINIMUM CAST-IN-PLACE CONCRETE FOUNDATION WALL DIMENSIONS, REINFORCEMENT AND MAXIMUM BRACED WALL LINE SPACING

WIND EXPOSURE CATEOGRY	ULTIMATE DESIGN WIND SPEED (miles per hour)	MINIMUM STEM WALL WIDTH (inches)	MINIMUM STEM WALL HEIGHT (inches)	MINIMUM HORIZONTAL REBAR	MAXIMUM BRACED WALL LINE SPACING (feet)
B	< 140	6	12	(2) - #4	28
C and D	< 140	8	18	(3) - #4	25

For SI: 1 inch = 25.4 mm, 1 foot = 304.8 mm, 1 mph = 0.447 m/s.

CHAPTER 5 FLOORS

R502.3.3	Wood Floor Framing	Editorial. Moving text from Footnote	No	NO	
----------	--------------------	--------------------------------------	----	----	--

2024 Code Section	TITLE OR SUBJECT	Reviewer Comments	Cost Yes/No	Amendment Needed Yes/No	TAG Comments/ Recommendation
<p>R502.3.3 Floor cantilevers. Floor cantilever spans shall not exceed the nominal depth of the wood floor joist. Floor cantilevers constructed in accordance with Table R502.3.3(1) shall be permitted where supporting a light-frame bearing wall and roof only. Floor cantilevers constructed in accordance with Table R502.3.3(2) shall be permitted where supporting an exterior balcony. A full-depth rim joist shall be provided at the unsupported end of the cantilever joists. Solid blocking shall be provided at the support for the cantilever. Where the cantilever length is 24 inches (610 mm) or less and the building is assigned to Seismic Design Category A, B or C, solid blocking at the support for the cantilever shall not be required.</p>					
R502.11	Wood Floor Framing	Prohibits the use of I-joists and trusses <i>as edge framing members supporting guards except where the effects of the guard loads are specifically considered in the design of the edge member.</i>	Decrease, See RB173-22	NO	
<p>R502.11 Floor framing supporting guards. The framing at the open edge of a floor supporting a required guard assembly shall be constructed in accordance with Section R502.11.1 or R502.11.2 for guard assemblies not exceeding 44 inches (1118 mm) in height, or shall be designed in accordance with accepted engineering practice to support the guard assembly. Where trusses and I-joists are used as edge framing members supporting guards, the effects of the guard loads shall be specifically considered in the design of the edge member.</p>					
R502.11.1	Wood Floor Framing	Describes the minimal thickness to resist withdrawal of fasteners	Decrease, See RB173-22	NO	
<p>R502.11.1 Conventional edge framing. Where a roll brace is aligned with each guard post, the framing at the edge of the floor shall consist of a solid or built-up member of lumber, structural glued-laminated timber or structural composite lumber having a net width of not less than 3 inches (76 mm) and a net depth of not less than 9¹/₄ inches (235 mm), and shall be braced to resist rotation by roll bracing as described in Section R502.11.3.</p>					
R502.11.2	Wood Floor Framing	Allows use of a thicker timber or glulam which is sized to resist torsion allowing roll bracing to be spaced at a	Decrease, See RB173-22	NO	

2024 Code Section	TITLE OR SUBJECT	Reviewer Comments	Cost Yes/No	Amendment Needed Yes/No	TAG Comments/ Recommendation
		maximum distance of 48 inches on center to alleviate the need for precise alignment of the post with the roll bracing or a joist.			
<p>R502.11.2 Timber edge framing. Where a roll brace is not aligned with each <i>guard</i> post, the framing at the edge of the floor shall consist of sawn timber not less than 6 inches by 10 inches or structural glued-laminated timber not less than 5¹/₈ inches by 9¹/₄ inches (130 mm × 235 mm) and shall be braced to resist rotation by roll bracing as described in Section R502.11.3 at intervals of 48 inches (1219 mm) or less.</p>					
R501.11.3	Wood Floor Framing	Provides Roll Bracing Specifications	Decrease, See RB173-22	NO	
<p>R502.11.3 Roll bracing. Each roll brace shall be a joist or blocking matching the depth of the edge member and extending perpendicular to the edge member not less than 16 inches (406 mm) from the edge. Blocking shall have end connections with not fewer than six 16d common nails. Floor sheathing shall be continuous for not less than 24 inches (610 mm) from the edge and shall be fastened to each roll brace with not fewer than 12 (twelve) 10d common nails and shall be fastened to the edge member with a minimum of 12 (twelve) 10d common nails within 12 inches (305 mm) of the roll brace.</p>					
R506.2	Concrete Floors (On Ground)	Adds Standard PTI DC10.5 for Post Tensioned Slabs	No	NO	
<p>R506.2 Post-tensioned slab-on-ground floors. Post-tensioned concrete slab-on-ground floors placed on expansive or stable soils shall be designed in accordance with PTI DC10.5</p>					
R506.3.3	Concrete Floors (On Ground)	Returns Vapor Retarder thickness to 2018 Req. 10 mil is intended for	Decrease	NO	

2024 Code Section	TITLE OR SUBJECT	Reviewer Comments	Cost Yes/No	Amendment Needed Yes/No	TAG Comments/ Recommendation
		commercial/Industrial Buildings			
<p>R506.3.3 Vapor retarder. A minimum 6 mil (0.006 inch; 152 µm) polyethylene or approved vapor retarder with joints lapped not less than 6 inches (152 mm) shall be placed between the concrete floor slab and the base course or the prepared subgrade where a base course does not exist. Exception: The vapor retarder is not required for the following: 1. Garages, utility <i>buildings</i> and other unheated <i>accessory structures</i>. 2. For unheated storage rooms having an area of less than 70 square feet (6.5 m²) and carports. 3. Driveways, walks, patios and other flatwork not likely to be enclosed and heated at a later date. 4. Where <i>approved</i> by the <i>building official</i>, based on local site conditions.</p>					
R507.2.3	Exterior Decks	Added language aligns with National Design Specification for Wood Construction Reqs.	No	NO	
<p>R507.2.3 Fasteners and connectors. Metal fasteners and connectors used for all decks shall be in accordance with Section R304.3 and Table R507.2.3. Holes for through bolts shall be drilled to a diameter of 1/32 inch to 1/16 inch larger than the bolt diameter. Connectors shall be installed in accordance with the manufacturer's approved instructions.</p>					
R507.2.4	Exterior Decks	Adds Standard for Self-Adhered Membranes. Already in Ch 7	No	NO	
<p>R507.2.4 Flashing. Flashing shall be corrosion-resistant metal of nominal thickness not less than 0.019 inch (0.48 mm) or <i>approved</i> nonmetallic material that is compatible with the substrate of the structure and the decking materials. Self-adhered membranes used as flashing and counterflashing shall comply with FGIA 711.</p>					
R507.5	Exterior Decks	New clarifying language. See Existing Amendment Report.	No	Incorporate into Existing Amendment	
<p>R507.5 Deck beams.</p>					

2024 Code Section	TITLE OR SUBJECT	Reviewer Comments	Cost Yes/No	Amendment Needed Yes/No	TAG Comments/ Recommendation
<p>Maximum allowable spans for wood deck beams, as shown in Figure R507.5, shall be in accordance with Tables R507.5(1) through R507.5(4) and based on the joist span length and cantilever length as shown in Figure R507.6. Beam plies shall be fastened together with two rows of 10d (3-inch × 0.128-inch) nails minimum at 16 inches (406 mm) on center along each edge. Deck beams of other materials shall be permitted where designed in accordance with accepted engineering practices.</p>					
T R507.5(1-4)	Exterior Decks	Tables Not Adopted	No	NO	
Tables Not Adopted					
R507.5.1	Exterior Decks	Each end of each ply of a multi-ply (“built-up”) beam must be supported on a bearing location.	No	NO	
<p>R507.5.1 Deck beam bearing. Beams and individual beam plies of built-up beams shall be continuous between bearing locations and continuous across bearing locations supporting beam cantilevers. Beams shall be permitted to cantilever beyond bearing locations up to one-fourth of the actual beam span. The ends of beams shall have not less than 1½ inches (38 mm) of bearing length on wood or metal and not less than 3 inches (76 mm) of bearing length on concrete or masonry for the entire width of the beam.</p>					
R50739.1.3	Exterior Decks	Added language aligns with National Design Specification for Wood Construction Reqs.	No	NO	
<p>R507.9.1.3 Ledger to band joist details. Where ledgers are fastened in accordance with Table R507.9.1.3(1), fasteners shall comply with Section R507.2.3 and shall be installed in accordance with Table R507.9.1.3(2) and Figures R507.9.1.3(1) and R507.9.1.3(2). Holes for ½-inch (12.7 mm) lag screws shall be predrilled with two drill bits so that a hole ½ inch (12.7mm) in diameter is drilled through the ledger and sheathing, if present, and a hole 5/16 inch (7.9 mm) to 3/8 inch (9.5mm) in diameter is drilled through the band joist.</p>					
R507.9.1.5	Exterior Decks	Adds Specific Details for Deck Ledger Flashing	Increase, See RB190-22	NO	
R507.9.1.5 Ledger flashing.					

2024 Code Section	TITLE OR SUBJECT	Reviewer Comments	Cost Yes/No	Amendment Needed Yes/No	TAG Comments/ Recommendation
<p>Where ledgers are attached to wood-frame construction, flashing shall be installed above the ledger to prevent the entry of water into the wall cavity or behind the ledger. Flashing shall extend vertically not less than 2 inches (51 mm) above the ledger. Flashing shall extend horizontally not less than 4 inches (102 mm) beyond the ledger face or shall extend to the ledger face and not less than 1/4 inch down the ledger face.</p> <p>Exceptions:</p> <ol style="list-style-type: none"> 1. Where a window or door opening is located less than 2 inches (51 mm) above the ledger, flashing shall extend to the bottom of the wall opening. 2. Flashing is not required where the ledger is spaced horizontally from the <i>exterior wall covering</i> not less than 1/4 inch (6.4 mm) to allow for drainage and ventilation behind the ledger. 					
R507.9.1.6	Exterior Decks	Adds Specific Details for Deck Ledger Flashing	Increase, See RB190-22	NO	
<p>R507.9.1.6 Water-resistive barrier.</p> <p>The water-resistive barrier required by Section R703.2 shall be lapped over a vertical leg of the ledger flashing or counterflashing extending up the wall by not less than 2 inches (51 mm) or the height of the vertical flashing leg, whichever is less. The <i>water-resistive barrier</i> shall continue from the top of the ledger flashing down the wall and behind the ledger flashing and ledger.</p> <p>Exceptions:</p> <ol style="list-style-type: none"> 1. Flashing shall be permitted to be placed against the face of the <i>water-resistive barrier</i> where a self-adhering membrane counterflashing is installed not less than 2 inches (51 mm) over the vertical leg of the flashing and not less than 2 inches (51 mm) onto the <i>water-resistive barrier</i>. 2. Flashing shall be permitted to be placed in front of the <i>water-resistive barrier</i> and behind the <i>exterior wall covering</i> where ledgers are spaced horizontally from the exterior wall not less than 1/4 inch (6.4 mm) to allow for drainage and ventilation behind the ledger. 					
R507.9.1.7	Exterior Decks	Adds Specific Details for Deck Ledger Flashing	Increase, See RB190-22	NO	
<p>R507.9.1.7 Existing walls.</p>					

2024 Code Section	TITLE OR SUBJECT	Reviewer Comments	Cost Yes/No	Amendment Needed Yes/No	TAG Comments/ Recommendation
<p>Where ledgers are attached to existing walls without water-resistive barriers, a <i>water-resistive barrier</i> shall be installed behind the ledger and ledger flashing. The <i>water-resistive barrier</i> shall extend to the top of the ledger flashing vertical leg and not less than 1/2 inch (12.7 mm) beyond the sides and bottom of the ledger. A self-adhering membrane counterflashing shall be installed not less than 2 inches (51 mm) over the vertical leg of the ledger flashing and not less than 2 inches (51 mm) onto the existing sheathing.</p> <p>Exceptions:</p> <ol style="list-style-type: none"> 1. 1.Where a window or door opening is located less than 2 inches (51 mm) above the ledger, flashing shall extend to the bottom of the wall opening. 2. 2.Flashing is not required where the ledger is spaced horizontally from the <i>exterior wall covering</i> not less than 1/4 inch (6.4 mm) to allow for drainage and ventilation behind the ledger. 					
R507.9.1.8	Exterior Decks	Adds Specific Details for Deck Ledger Flashing	Increase, See RB190-22	NO	
<p>R507.9.1.8 Exterior wall coverings.</p> <p><i>Exterior wall coverings</i> shall be terminated above the finished deck surface in accordance with the covering manufacturer's requirements and Chapter 7, as applicable to the type of covering.</p> <p>Exception: <i>Exterior wall coverings</i> shall be permitted behind ledgers in accordance with Section R507.9.1.5 where capable of resisting compression forces from the ledger attachment.</p>					
CHAPTER 6 WALL COVERING					
T R602.3(1) Footnote f.	Wood Wall Framing	Specifies use of RSRS-03 Nail where Roof sheathing is	Increase, See RB193-22	NO	

2024 Code Section	TITLE OR SUBJECT	Reviewer Comments	Cost Yes/No	Amendment Needed Yes/No	TAG Comments/ Recommendation
		attached to framing having a specific gravity greater than 0.35 but less than 0.42.			
f. For wood structural panel roof sheathing attached to gable end roof framing and to intermediate supports within 48 inches of roof edges and ridges, nails shall be spaced at 4 inches on center where the ultimate design wind speed is greater than 130 mph in Exposure B or greater than 110 mph in Exposure C. Fastener spacing applies where roof framing specific gravity is 0.42 or larger. Where roof framing specific gravity is greater than or equal to 0.35 but less than 0.42 in accordance with <u>AWC NDS</u>, fastening of roof sheathing shall be with RSRS-03 (2¹/₂" x 0.131" x 0.281" head) nails.					
T R602.3(2) Footnote g.	Wood Wall Framing	Limits alternate fasteners for roof sheathing to wood species having a specific gravity of 0.42 or greater	No	NO	
g. Alternate fastening is only permitted for roof sheathing where the ultimate design wind speed is less than or equal to 110 mph, and where fasteners are installed 3 inches on center at all supports, and where fastening is to wood framing of a species with specific gravity greater than or equal to 0.42 in accordance with <u>AWC NDS</u>.					
T R602.3(3) Footnote d.	Wood Wall Framing	For WSP maximum nail spacing of 8in when framing wood species has specific gravity of greater than 0.35 but less than 0.42.	Increase, See RB195-22	NO	
d. Fastener spacing applies where wall framing specific gravity is 0.42 or larger. Where wall framing specific gravity is greater than or equal to 0.35 but less than 0.42 in accordance with <u>AWC NDS</u>, maximum nail spacing in the field of the panel shall be 8 inches.					
R602.7.2	Wood Wall Framing	Corrects the number of full-height studs required at the	Increase, See RB197-22	NO	

2024 Code Section	TITLE OR SUBJECT	Reviewer Comments	Cost Yes/No	Amendment Needed Yes/No	TAG Comments/ Recommendation
		edge of openings using rim board headers.			
<p>R602.7.2 Rim board headers. Rim board header size, material and span shall be in accordance with Table R602.7(1). Rim board headers shall be constructed in accordance with Figure R602.7.2 and shall be supported at each end by full-height studs. The number of full-height studs at each end shall be not less than one plus the number of studs displaced by half of the header span based on the maximum stud spacing in accordance with Table R602.3(5). Rim board headers supporting concentrated loads shall be designed in accordance with accepted engineering practice.</p>					
R602.10.3.1	Wood Wall Framing	Clarifies how to determine the vertical dimension of the wall height for wood stud framing. New Figure 602.10.3.1	No	NO	
<p>R602.10.3.1 Wall height for wood framing. For determination of braced wall and panel adjustment factors in accordance with Section R602.10, wall height shall be the vertical distance from the lower edge of the bottom plate to the upper edge of the upper top plate determined in accordance with Figure R602.10.3.1.</p>					
R602.10.6	Wood Wall Framing	Since the full length of the header is taking shear loads out of the top plate, the edge of the portal is the end of the header.	No	NO	
<p>R602.10.6 Construction of Methods ABW, PFH, PFG, CS-PF and BV-WSP. Methods ABW, PFH, PFG, CS-PF and BV-WSP shall be constructed as specified in Sections R602.10.6.1 through R602.10.6.5. For the purposes of determining <i>braced wall panel</i> spacing and end distance, the edge of Methods PFH, PFG and CS-PF shall be defined as the end of the header.</p>					
CHAPTER 7 WALL COVERING					

2024 Code Section	TITLE OR SUBJECT	Reviewer Comments	Cost Yes/No	Amendment Needed Yes/No	TAG Comments/ Recommendation
R702.7	Interior Covering	Coordinates installation of vapor retarders between Part II and Part IV of the IRC. Amendment Needed to remove reference to Chapter 11.	No	YES	
<p>R702.7 Vapor retarders. Vapor retarder materials shall be classified in accordance with Table R702.7(1). A vapor retarder shall be provided on the interior side of frame walls of the class indicated in Table R702.7(2), including compliance with Table R702.7(3) or R702.7(4) where applicable. An <i>approved</i> design using accepted engineering practice for hygrothermal analysis shall be permitted as an alternative. Vapor retarders shall be installed in accordance with Section R702.7.2. The <i>climate zone</i> shall be determined in accordance with Section N1101.7.</p> <p>Exceptions:</p> <ol style="list-style-type: none"> 1. <i>Basement walls.</i> 2. Below-grade portion of any wall. 3. Construction where accumulation, condensation or freezing of moisture will not damage the materials. 4. A vapor retarder shall not be required in <i>Climate Zones</i> 1, 2 and 3. 5. In Climate Zones 4 through 8, a vapor retarder shall not be required where the assembly complies with Table R702.7(5). 					

2024 Code Section	TITLE OR SUBJECT	Reviewer Comments	Cost Yes/No	Amendment Needed Yes/No	TAG Comments/ Recommendation
T R702.7(2)	Interior Covering	Adds responsive / Class I Vapor Retarders to the section	No	NO	

TABLE R702.7(2)VAPOR RETARDER OPTIONS



CLIMATE ZONE	VAPOR RETARDER CLASS		
	CLASS I ^a	CLASS II ^a	CLASS III
1, 2	Not Permitted	Not Permitted	Permitted
3, 4 (except Marine 4)	Not Permitted	Permitted ^c	Permitted
Marine 4, 5, 6, 7, 8	Permitted ^{b, c}	Permitted ^c	See Table R702.7(3)

- a. A responsive vapor retarder shall be allowed on the interior side of any frame wall in all climate zones.
- b. In frame walls, use of a Class I vapor retarder that is not a responsive vapor retarder on the interior side with a Class I vapor retarder on the exterior side shall require an approved design.
- c. Where a Class I or II vapor retarder is used in combination with foam plastic insulating sheathing or insulated siding installed as continuous insulation on the exterior side of frame walls, the continuous insulation shall comply with [Table R702.7\(4\)](#) and the Class I or II vapor retarder shall be a responsive vapor retarder.

T R702.7(4)	Interior Covering	Adds Class I Responsive Vapor Retarders to Table Title	No	NO	
-------------	-------------------	--	----	----	--

TABLE R702.7(4) CONTINUOUS INSULATION WITH CLASS I OR II RESPONSIVE VAPOR RETARDER

CLIMATE ZONE	PERMITTED CONDITIONS ^a
3	Continuous insulation with R -value ≥ 2 .
4, 5 and 6	Continuous insulation with R -value ≥ 3 over 2×4 wall. Continuous insulation with R -value ≥ 5 over 2×6 wall.
7	Continuous insulation with R -value ≥ 5 over 2×4 wall. Continuous insulation with R -value ≥ 7.5 over 2×6 wall.
8	Continuous insulation with R -value ≥ 7.5 over 2×4 wall. Continuous insulation with R -value ≥ 10 over 2×6 wall.

2024 Code Section	TITLE OR SUBJECT	Reviewer Comments	Cost Yes/No	Amendment Needed Yes/No	TAG Comments/ Recommendation
T R702.7(5)	Interior Covering	Adds new option to control water vapor using exterior continuous insulation	No	NO	

TABLE R702.7(5)

CONTINUOUS INSULATION ON WALLS WITHOUT A CLASS I, II OR III INTERIOR VAPOR RETARDER^a

CLIMATE ZONE	PERMITTED CONDITIONS ^{b, c}
4	Continuous insulation with <i>R</i> -value ≥ 4.5
5	Continuous insulation with <i>R</i> -value ≥ 6.5
6	Continuous insulation with <i>R</i> -value ≥ 8.5
7	Continuous insulation with <i>R</i> -value ≥ 11.5
8	Continuous insulation with <i>R</i> -value ≥ 14

- a. The total insulating value of materials to the interior side of the exterior continuous insulation, including any cavity insulation, shall not exceed R-5. Where the *R*-value of materials to the interior side of the exterior continuous insulation exceeds R-5, an approved design shall be required.
- b. A water vapor control material layer having a permeance not greater than 1 perm in accordance with [ASTM E96](#) Procedure A (dry cup) shall be placed on the exterior side of the wall and to the interior side of the exterior continuous insulation. The exterior continuous insulation shall be permitted to serve as the vapor control layer where, at its installed thickness or with a facer on its interior face, the exterior continuous insulation is a Class I or II vapor retarder.
- c. The requirements in this table apply only to insulation used to control moisture in order to allow walls without a Class I, II or III interior vapor retarder. The insulation materials used to satisfy this option also contribute to but do not supersede the thermal envelope requirements of the [International Energy Conservation Code](#).

2024 Code Section	TITLE OR SUBJECT	Reviewer Comments	Cost Yes/No	Amendment Needed Yes/No	TAG Comments/ Recommendation
R702.7.2	Interior Covering	New Section. Clarifies Vapor Retarder Installation. Need to change reference to Ch 11 to WSEC-R	No	YES	
<p>R702.7.2 Vapor retarder installation. Vapor retarders shall be installed in accordance with the manufacturer’s instructions, accepted installation methods or an <i>approved</i> design. Where a vapor retarder also functions as a component of a continuous <i>air barrier</i>, the vapor retarder shall be installed as an <i>air barrier</i> in accordance with Section N1102.5.1.1.</p>					

2024 Code Section	TITLE OR SUBJECT	Reviewer Comments	Cost Yes/No	Amendment Needed Yes/No	TAG Comments/ Recommendation
R703.2	Exterior Wall Covering	Where WRB Serves as Air barrier it must also comply with Energy Provisions. Allow Foam Plastics to be used as WRB. Also adds exception for detached unconditioned accessory structures. Need to change reference to Ch 11 to WSEC-R	No	YES	
<p>R703.2 Water-resistive barrier.</p> <p>Not fewer than one layer of <i>water-resistive barrier</i> shall be applied over studs or sheathing of all exterior walls with flashing as indicated in Section R703.4, in such a manner as to provide a continuous <i>water-resistive barrier</i> behind the exterior wall veneer and behind deck ledgers. The <i>water-resistive barrier</i> material shall be continuous to the top of walls and terminated at penetrations and building appendages in a manner to meet the requirements of the exterior wall envelope as described in Section R703.1. Where the <i>water-resistive barrier</i> also functions as a component of a continuous <i>air barrier</i>, the <i>water-resistive barrier</i> shall be installed as an <i>air barrier</i> in accordance with Section N1102.5.1.1. <i>Water-resistive barrier</i> materials shall comply with one of the following:</p> <ol style="list-style-type: none"> 1.No. 15 felt complying with ASTM D226, Type 1. 2.ASTM E2556, Type 1 or 2. 3.Foam plastic <i>insulating sheathing</i> <i>water-resistive barrier</i> systems complying with Section R703.1.1 and installed in accordance with the manufacturer's installation instructions. 4.ASTM E331 in accordance with Section R703.1.1. 5.Other <i>approved</i> materials in accordance with the manufacturer's installation instructions. <p>No.15 asphalt felt and <i>water-resistive barriers</i> complying with ASTM E2556 shall be applied horizontally, with the upper layer lapped over the lower layer not less than 2 inches (51 mm), and where joints occur, shall be lapped not less than 6 inches (152 mm).</p> <p>Exception: A <i>water-resistive barrier</i> shall not be required in unconditioned detached tool sheds, storage sheds, playhouses, and other similar <i>accessory structures</i> provided all of the following requirements are met:</p> <ol style="list-style-type: none"> 1.<i>Exterior wall covering</i> is limited to siding that is attached direct to studs. 2.Exterior walls are uninsulated. 3.Interior side of exterior walls has no wall covering or wall finishes. 					

2024 Code Section	TITLE OR SUBJECT	Reviewer Comments	Cost Yes/No	Amendment Needed Yes/No	TAG Comments/ Recommendation
R703.3.1	Exterior Wall Covering	This is a common practice but worth noting in the code to ensure proper siding performance and moisture / heat issues.	No	NO	
<p>R703.3.1 Siding clearance at wall and adjacent surfaces. Unless otherwise specified by the cladding manufacturer or this code, polypropylene, insulated vinyl and vinyl <i>claddings</i> shall have clearance of not less than 6 inches (152 mm) from the ground and not less than 1/2 inch (13 mm) from other adjacent surfaces (decks, roofs, slabs).</p>					
R703.6.1	Exterior Wall Covering	Provides an alternative horizontal furring installation that provides a gap for drainage and ventilation for vertical furring installed over a nonpermeable WRB.	Decrease, See RB222-22	NO	
<p>R703.6.1 Application. Wood shakes or shingles shall be applied either single course or double course over nominal 1/2-inch (12.7 mm) wood-based sheathing or to furring strips over 1/2-inch (12.7 mm) nominal nonwood sheathing. A <i>water-resistive barrier</i> shall be provided in accordance with Section R703.2. Where horizontal furring strips are used, they shall be 1 inch by 3 inches or 1 inch by 4 inches (25 mm by 76 mm or 25 mm by 102 mm) and shall be fastened to the studs with minimum 7d or 8d box nails and shall be spaced a distance on center equal to the actual weather exposure of the shakes or shingles, not to exceed the maximum exposure specified in Table R703.6.1. When installing shakes or shingles over a nonpermeable <i>water-resistive barrier</i>, furring strips shall be placed first vertically over the <i>water-resistive barrier</i> and in addition, horizontal furring strips shall be fastened to the vertical furring strips prior to attaching the shakes or shingles to the horizontal furring strips. Alternatively, horizontal furring shall be gapped not less than 3/16 inch from the surface of the water-resistive barrier without the requirement for a vertical furring strip. Where installed over foam plastic insulating sheathing, furring attachments shall comply with Section R703.15, R703.16 or R703.17. The spacing between adjacent shingles to allow for expansion shall be 1/8 inch (3.2 mm) to 1/4 inch (6.4 mm) apart, and between adjacent shakes shall be 3/8 inch (9.5 mm) to 1/2 inch (12.7 mm) apart. The offset spacing between joints in adjacent courses shall be not less than 1 1/2 inches (38 mm).</p>					

2024 Code Section	TITLE OR SUBJECT	Reviewer Comments	Cost Yes/No	Amendment Needed Yes/No	TAG Comments/ Recommendation
R703.7.3	Exterior Wall Covering	This change expands explicit drainage to stucco systems applied over any exterior sheathing and recognizes materials that are not impacted	Increase, See S240-22 PtII	NO	
<p>R703.7.3 Water-resistive barriers. Water-resistive barriers shall be installed as required in Section R703.2 and shall comply with Section R703.7.3.1 or R703.7.3.2. Exception: Sections R703.7.3.1 and R703.7.3.2 shall not apply to construction where accumulation, condensation or freezing of moisture will not damage the materials.</p>					
R703.7.3.1	Exterior Wall Covering	Clarifies the Dry Climate Option 2 to emphasize that a means of drainage is included in the design of the water-resistive barrier system.	No	NO	

2024 Code Section	TITLE OR SUBJECT	Reviewer Comments	Cost Yes/No	Amendment Needed Yes/No	TAG Comments/ Recommendation
<p>R703.7.3.1 Dry climates.</p> <p>In Dry (B) <i>climate zones</i> indicated in Figure N1101.7, <i>water-resistive barriers</i> shall comply with one of the following:</p> <ol style="list-style-type: none"> 1. 1.The <i>water-resistive barrier</i> shall be two layers of 10-minute Grade D paper or have a water resistance equal to or greater than two layers of a <i>water-resistive barrier</i> complying with ASTM E2556, Type I. The individual layers shall be installed independently such that each layer provides a separate continuous plane. Flashing installed in accordance with Section R703.4 and intended to drain to the <i>water-resistive barrier</i> shall be directed between the layers. 2. 2.The <i>water-resistive barrier</i> shall be 60-minute Grade D paper or have a water resistance equal to or greater than one layer of a <i>water-resistive barrier</i> complying with ASTM E2556, Type II. The <i>water-resistive barrier</i> shall be separated from the stucco by a layer of foam plastic <i>insulating sheathing</i>, other non-water-absorbing layer, a drainage space or means of drainage complying with Section R703.7.3.2. Flashing installed in accordance with Section 703.4 and intended to drain to the <i>water-resistive barrier</i> shall be directed to the exterior side of the <i>water-resistive barrier</i>. 					
R703.8.2.2	Exterior Wall Covering	Simplifies the installation of the flashing and the masonry veneer. Also Include 2 new Figures to accompany Section.	Decrease, See RB226-22	NO	

2024 Code Section	TITLE OR SUBJECT	Reviewer Comments	Cost Yes/No	Amendment Needed Yes/No	TAG Comments/ Recommendation
		<p>R703.8.2.2 Support by ledger or roof construction.</p> <p>A steel angle shall be placed directly on top of the ledger or roof construction. The ledger or roof construction supporting the steel angle shall consist of not fewer than three 2-inch by 6-inch (51 mm × 152 mm) wood members for wood construction or three 550S162 cold-formed steel members for cold-formed steel <i>light frame construction</i>. The wood member abutting the vertical wall stud construction shall be anchored with not fewer than three ⁵/₈-inch (15.9 mm) diameter by 5-inch (127 mm) lag screws to every wood stud spacing. Each additional wood roof member shall be anchored by the use of two 10d nails at every wood stud spacing. A cold-formed steel member abutting the vertical wall stud shall be anchored with not fewer than nine No. 8 screws to every cold-formed steel stud. Each additional cold-formed steel roof member shall be anchored to the adjoining roof member using two No. 8 screws at every stud spacing. Not less than two-thirds the width of the masonry veneer thickness shall bear on the steel angle. Flashing and weep holes shall be located in the masonry veneer wythe in accordance with Figure R703.8.2.2(1) or R703.8.2.2(2). The maximum height of the masonry veneer above the steel angle support shall be 12 feet 8 inches (3861 mm). The airspace separating the masonry veneer from the wood backing shall be in accordance with Sections R703.8.4 and R703.8.4.2. The support for the masonry veneer shall be constructed in accordance with Figure R703.8.2.2(1) or R703.8.2.2(2).</p> <p>The maximum slope of a steel angle installed without stops shall be 7:12. A steel angle installed with a slope greater than 7:12 but not more than 12:12 shall have stops of a minimum 3-inch by 3-inch by ¹/₄-inch (76 mm × 76 mm × 6.4 mm) steel plate welded to the angle at 24 inches (610 mm) on center along the angle or as <i>approved</i> by the <i>building official</i>.</p>			
T R703.8.3.1	Exterior Wall Covering	Provides steel angle lintel sizes for brick veneer made of nominal 3-inch wide masonry units	Decrease, See RB227-22	NO	

2024 Code Section	TITLE OR SUBJECT	Reviewer Comments	Cost Yes/No	Amendment Needed Yes/No	TAG Comments/ Recommendation																														
<p>TABLE R703.8.3.1 ALLOWABLE SPANS FOR LINTELS SUPPORTING MASONRY VENEER^{a, b, c, d}</p> <table border="1" data-bbox="216 334 1283 646"> <thead> <tr> <th>SIZE OF STEEL ANGLE^{a, c, d} (inches)</th> <th>NO STORY ABOVE</th> <th>ONE STORY ABOVE</th> <th>TWO STORIES ABOVE</th> <th>NO. OF 1/2-INCH OR EQUIVALENT REINFORCING BARS IN REINFORCED LINTEL^{b, d}</th> </tr> </thead> <tbody> <tr> <td>3 x 3 x 1/4</td> <td>6'-0"</td> <td>4'-6"</td> <td>3'-0"</td> <td>1</td> </tr> <tr> <td>4 x 3 x 1/4</td> <td>8'-0"</td> <td>6'-0"</td> <td>4'-6"</td> <td>1</td> </tr> <tr> <td>5 x 3 x 5/16 or 5 x 3 1/2 x 5/16</td> <td>10'-0"</td> <td>8'-0"</td> <td>6'-0"</td> <td>2</td> </tr> <tr> <td>6 x 3 1/2 x 5/16 or 5 x 3 x 5/16 with two 9-gauge wires between first and second course</td> <td>14'-0"</td> <td>9'-6"</td> <td>7'-0"</td> <td>2</td> </tr> <tr> <td>2-6 x 3 1/2 x 5/16</td> <td>20'-0"</td> <td>12'-0"</td> <td>9'-6"</td> <td>4</td> </tr> </tbody> </table> <p data-bbox="216 667 1283 792"> <small>For SI: 1 inch = 25.4 mm, 1 foot = 304.8 mm. a. Long leg of the angle shall be placed in a vertical position. b. Depth of reinforced lintels shall be not less than 8 inches and all cells of hollow masonry lintels shall be grouted solid. Reinforcing bars shall extend not less than 8 inches into the support. c. Steel members indicated are adequate typical examples; other steel members meeting structural design requirements shall be permitted to be used. d. Use either steel angle or reinforced lintel to span opening.</small> </p>						SIZE OF STEEL ANGLE ^{a, c, d} (inches)	NO STORY ABOVE	ONE STORY ABOVE	TWO STORIES ABOVE	NO. OF 1/2-INCH OR EQUIVALENT REINFORCING BARS IN REINFORCED LINTEL ^{b, d}	3 x 3 x 1/4	6'-0"	4'-6"	3'-0"	1	4 x 3 x 1/4	8'-0"	6'-0"	4'-6"	1	5 x 3 x 5/16 or 5 x 3 1/2 x 5/16	10'-0"	8'-0"	6'-0"	2	6 x 3 1/2 x 5/16 or 5 x 3 x 5/16 with two 9-gauge wires between first and second course	14'-0"	9'-6"	7'-0"	2	2-6 x 3 1/2 x 5/16	20'-0"	12'-0"	9'-6"	4
SIZE OF STEEL ANGLE ^{a, c, d} (inches)	NO STORY ABOVE	ONE STORY ABOVE	TWO STORIES ABOVE	NO. OF 1/2-INCH OR EQUIVALENT REINFORCING BARS IN REINFORCED LINTEL ^{b, d}																															
3 x 3 x 1/4	6'-0"	4'-6"	3'-0"	1																															
4 x 3 x 1/4	8'-0"	6'-0"	4'-6"	1																															
5 x 3 x 5/16 or 5 x 3 1/2 x 5/16	10'-0"	8'-0"	6'-0"	2																															
6 x 3 1/2 x 5/16 or 5 x 3 x 5/16 with two 9-gauge wires between first and second course	14'-0"	9'-6"	7'-0"	2																															
2-6 x 3 1/2 x 5/16	20'-0"	12'-0"	9'-6"	4																															
R703.11.1.1	Exterior Wall Covering	Starter strips, a critical installation element for vinyl siding sometime ignored by installers. Includes Figure to accompany Section.	No	NO																															
<p>R703.11.1.1 Starter strip. The first course of horizontal siding shall be secured using a starter strip as specified in the manufacturer's installation instructions. See Figure R703.11.1.1(1). Where the first course of siding has to be cut or trimmed, the bottom edge shall be secured with utility trim and snap locks as specified by the manufacturer's installation instructions.</p>																																			
R703.11.1.2	Exterior Wall Covering	Utility trim, a critical installation element for vinyl siding wind performance system is sometime ignored	No	NO																															

2024 Code Section	TITLE OR SUBJECT	Reviewer Comments	Cost Yes/No	Amendment Needed Yes/No	TAG Comments/ Recommendation
		by installers. Includes 2 Figures to accompany Section.			
<p>R703.11.1.2 Utility trim. Where horizontal siding has to be cut or trimmed below windows and at the top of walls, the top edge of the siding shall be secured with utility trim and snap locks or as specified by the manufacturer's installation instructions. See Figures R703.11.1.2(1) and R703.11.1.2(2).</p>					
R703.14.1.1.1	Exterior Wall Covering	Cleans up the section on polypropylene siding.	No	NO	
<p>R703.14.1.1.1 Starter strip. Horizontal siding shall be installed with a starter strip at the initial course at any location. Where the installation of a starter strip is not possible, other approved equivalents shall be permitted.</p>					
R703.14.1.1.2	Exterior Wall Covering	Cleans up the section on polypropylene siding. Includes New Figure	No	NO	
<p>R703.14.1.1.2 Under windows and top of walls. Where the nail hem is removed, such as under windows and at the top of walls, nail slot punch or predrilled holes shall be constructed as shown in Figure R703.14.1.1.2 (1).</p>					
R703.14.1.2	Exterior Wall Covering	Cleans up the section on polypropylene siding.	No	NO	
<p>R703.14.1.2 Fastener requirements. Unless otherwise specified in the manufacturer's installation instructions, nails shall be corrosion resistant, with a minimum 0.120-inch (3 mm) shank and minimum 0.313-inch (8 mm) head diameter. Nails shall be a minimum of 1¹/₄ inches (32 mm) long or as necessary to penetrate sheathing or <i>nailable substrate</i> not less than ³/₄ inch (19.1 mm). Where the nail fully penetrates the sheathing or <i>nailable substrate</i>, the end of the fastener shall extend not less than ¹/₄ inch (6.4 mm) beyond the opposite face of the sheathing or <i>nailable substrate</i>. Spacing of fasteners shall be installed in accordance with the manufacturer's installation instructions</p>					
T R703.15.1	Exterior Wall Covering	Clarifies Table with additional footnotes.	No	NO	

2024 Code Section	TITLE OR SUBJECT	Reviewer Comments	Cost Yes/No	Amendment Needed Yes/No	TAG Comments/ Recommendation
-------------------	------------------	-------------------	-------------	-------------------------	------------------------------

TABLE R703.15.1

CLADDING MINIMUM FASTENING REQUIREMENTS FOR DIRECT ATTACHMENT OVER FOAM PLASTIC SHEATHING TO SUPPORT CLADDING WEIGHT^a

CLADDING FASTENER MINIMUM PENETRATION INTO WOOD WALL FRAMING ^b	CLADDING FASTENER TYPE AND MINIMUM SIZE ^c	CLADDING FASTENER VERTICAL SPACING ^d (inches)	MAXIMUM THICKNESS OF FOAM SHEATHING ^e (inches)									
			16" o.c. Fastener Horizontal Spacing					24" o.c. Fastener Horizontal Spacing				
			Cladding Weight: ^f					Cladding Weight: ^f				
			3 psf	11 psf	15 psf	18 psf	25 psf	3 psf	11 psf	15 psf	18 psf	25 psf
1 1/4 inch	0.113" diameter nail	6	2.00	1.45	1.00	0.75	DR	2.00	0.85	0.55	DR	DR
		8	2.00	1.00	0.65	DR	DR	2.00	0.55	DR	DR	DR
		12	2.00	0.55	DR	DR	DR	1.85	DR	DR	DR	DR
	0.120" diameter nail	6	3.00	1.70	1.15	0.90	0.55	3.00	1.05	0.65	0.50	DR
		8	3.00	1.20	0.80	0.60	DR	3.00	0.70	DR	DR	DR
		12	3.00	0.70	DR	DR	DR	2.15	DR	DR	DR	DR
	0.131" diameter nail	6	4.00	2.15	1.50	1.20	0.75	4.00	1.35	0.90	0.70	DR
		8	4.00	1.55	1.05	0.80	DR	4.00	0.90	0.55	DR	DR
		12	4.00	0.90	0.55	DR	DR	2.70	0.50	DR	DR	DR
	0.162" diameter nail	6	4.00	3.55	2.50	2.05	1.40	4.00	2.25	1.55	1.25	0.80
		8	4.00	2.55	1.80	1.45	0.95	4.00	1.60	1.10	0.85	0.50
		12	4.00	1.60	1.10	0.85	0.50	4.00	0.95	0.60	DR	DR

For SI: 1 inch = 25.4 mm, 1 pound per square foot = 0.0479 kPa, 1 pound per square inch = 6.895 kPa.
DR = Design Required.
o.c. = On Center.

- a. Wood framing shall be Spruce-pine-fir or any wood species with a specific gravity of 0.42 or greater in accordance with [AWC NDS](#).
- b. The thickness of wood structural panels complying with the specific gravity requirement of Note a shall be permitted to be included in satisfying the minimum penetration into framing. For cladding connections to wood structural panels, refer to [Table R703.3.3](#). For brick veneer tie connections to wood structural panels, refer to [Table R703.8.4\(2\)](#).
- c. Nail fasteners shall comply with ASTM F1667, except nail length shall be permitted to exceed ASTM F1667 standard lengths.
- d. Fastener vertical spacing is an average spacing associated with the following nail count per foot: 6-inch spacing is associated with two nails per foot, 8-inch spacing is associated with 1.5 nails per foot, and 12-inch spacing is associated with one nail per foot.
- e. Foam sheathing shall have a minimum compressive strength of 15 psi in accordance with [ASTM C578](#) or [ASTM C1289](#).
- f. Cladding weight is the maximum weight of cladding materials in pounds per square foot of wall area. The 3 psf category typically applies to panel and lap siding materials; the 11 psf category typically applies to conventional three-coat stucco of 7/8-inch thickness; and 15 psf to 25 psf categories typically apply to adhered masonry veneers.

T R703.15.2 Footnote g.	Exterior Wall Covering	Clarifies Weight Categories	No	NO	
----------------------------	---------------------------	-----------------------------	----	----	--

2024 Code Section	TITLE OR SUBJECT	Reviewer Comments	Cost Yes/No	Amendment Needed Yes/No	TAG Comments/ Recommendation
-------------------	------------------	-------------------	-------------	-------------------------	------------------------------

TABLE R703.15.2
FURRING MINIMUM FASTENING REQUIREMENTS FOR APPLICATION OVER FOAM PLASTIC SHEATHING TO SUPPORT CLADDING WEIGHT^{a, b}

FURRING MATERIAL	FRAMING MEMBER	FASTENER TYPE AND MINIMUM SIZE	MINIMUM PENETRATION INTO WALL FRAMING (inches) ^c	FASTENER SPACING IN FURRING (inches)	MAXIMUM THICKNESS OF FOAM SHEATHING ^e (inches)										
					16" o.c. Furring ^f					24" o.c. Furring ^f					
					Siding Weight: ^g										
					3 psf	11 psf	15 psf	18 psf	25 psf	3 psf	11 psf	15 psf	18 psf	25 psf	
Minimum 1× wood furring ^d	Minimum 2× wood stud	0.131" diameter nail	1 1/4	8	4.00	2.45	1.75	1.45	0.95	4.00	1.60	1.10	0.85	DR	
				12	4.00	1.60	1.10	0.85	DR	4.00	0.95	0.55	DR	DR	
				16	4.00	1.10	0.70	DR	DR	3.05	0.60	DR	DR	DR	
		0.162" diameter nail	1 1/4	8	4.00	4.00	3.05	2.45	1.60	4.00	2.75	1.85	1.45	0.85	DR
				12	4.00	2.75	1.85	1.45	0.85	4.00	1.65	1.05	0.75	DR	
				16	4.00	1.90	1.25	0.95	DR	4.00	1.05	0.60	DR	DR	
	No.10 wood screw	1	12	4.00	2.30	1.60	1.20	0.70	4.00	1.40	0.85	0.60	DR		
			16	4.00	1.65	1.05	0.75	DR	4.00	0.90	DR	DR	DR		
			24	4.00	0.90	DR	DR	DR	2.85	DR	DR	DR	DR		
	1/4" lag screw	1 1/2	12	4.00	2.65	1.90	1.50	0.90	4.00	1.65	1.05	0.80	DR		
			16	4.00	1.95	1.25	0.95	0.50	4.00	1.10	0.65	DR	DR		
			24	4.00	1.10	0.65	DR	DR	3.25	0.50	DR	DR	DR		

For SI: 1 inch = 25.4 mm, 1 pound per square foot = 0.0479 kPa, 1 pound per square inch = 6.895 kPa.

DR = Design Required.

o.c. = On Center.

- a. Wood framing and furring shall be Spruce-pine-fir or any wood species with a specific gravity of 0.42 or greater in accordance with [AWC NDS](#).
- b. Nail fasteners shall comply with ASTM F1667, except nail length shall be permitted to exceed ASTM F1667 standard lengths.
- c. The thickness of wood structural panels complying with the specific gravity requirements of Note a shall be permitted to be included in satisfying the minimum required penetration into framing.
- d. Where the required cladding fastener penetration into wood material exceeds 3/4 inch and is not more than 1 1/2 inches, a minimum 2× wood furring or an approved design shall be used.
- e. Foam sheathing shall have a minimum compressive strength of 15 psi in accordance with [ASTM C578](#) or [ASTM C1289](#).
- f. Furring shall be spaced not more than 24 inches on center, in a vertical or horizontal orientation. In a vertical orientation, furring shall be located over wall studs and attached with the required fastener spacing. In a horizontal orientation, the indicated 8-inch and 12-inch fastener spacing in furring shall be achieved by use of two fasteners into studs at 16 inches and 24 inches on center, respectively.
- g. Cladding weight is the maximum weight of cladding materials in pounds per square foot of wall area. The 3 psf category typically applies to panel and lap siding materials; the 11 psf category typically applies to conventional three-coat stucco of 7/8-inch thickness, and 15 psf to 25 psf categories typically apply to adhered masonry veneers.

R703.18	Exterior Wall Covering	Exterior use of cement board is now permitted by the C1325 standard	No	NO	
---------	------------------------	---	----	----	--

2024 Code Section	TITLE OR SUBJECT	Reviewer Comments	Cost Yes/No	Amendment Needed Yes/No	TAG Comments/ Recommendation
<p>R703.18 Fiber-mat reinforced cementitious backer units. Fiber-mat reinforced cementitious backer units used on exterior walls as a substrate for the application of exterior finish materials shall comply with ASTM C1325. Installation shall be in accordance with the manufacturer's installation instructions. Backer units shall be installed using corrosion-resistant fasteners. Finish materials shall be installed in accordance with the manufacturer's instructions.</p>					
T R704.3.4	Exterior Soffits and Facias	Addresses the use of soffit framing of wood species having lower specific gravity than the value of 0.42 associated with prescribed spacing of nails.	No	NO	
<p>e. Fastener spacing applies where wood exterior soffit framing member-specific gravity is 0.42 or larger. Where the specific gravity of exterior soffit framing members is greater than or equal to 0.35 but less than 0.42 in accordance with AWC NDS, the fastener spacing shall be multiplied by 0.67 or the same fastener spacing as prescribed for galvanized steel nails shall be permitted to be used where RSRs-01 (2-inch by 0.099-inch by 0.266-inch head) nails replace 6d box nails and RSRs-03 (2½-inch × 0.131-inch × 0.281-inch head) nails replace 8d common nails or 10d box nails. RSRs is a Roof Sheathing Ring Shank nail meeting the specifications in ASTM F1667. Framing members shall be minimum 2 × 3 nominal with the larger dimension in the cross section aligning with the length of fasteners to provide sufficient embedment depths.</p>					
R704.4	Exterior Soffits and Facias	Provide specific direction for the installation of fascia at the eaves and rakes.	Increase, See RB237-22	NO	
<p>R704.4 Fascia. Fascia shall be installed in accordance with the manufacturer's installation instructions.</p>					
R704.4.1	Exterior Soffits and Facias	Provide specific direction for the installation of fascia at the eaves and rakes.	Increase, See RB237-22	NO	
<p>R704.4.1 Aluminum fascia. Aluminum fascia shall be installed in accordance with the manufacturer's installation instructions and comply with Section R704.4.1.1 or R704.4.1.2.</p>					
R704.4.1.1	Exterior Soffits and Facias	Provide specific direction for the installation of fascia at the eaves and rakes.	Increase, See RB237-22	NO	

2024 Code Section	TITLE OR SUBJECT	Reviewer Comments	Cost Yes/No	Amendment Needed Yes/No	TAG Comments/ Recommendation
<p>R704.4.1.1 Fascia installation where the design wind pressure is 30 psf or less. Where the design wind pressure is 30 pounds per square foot (1.44 kPa) or less, aluminum fascia shall be attached with one finish nail [1 1/4 inches by 0.57 inch by 0.177 inch head diameter (32 mm × 14.5 mm × 4.5 mm)] in the return leg spaced a maximum of 24 inches (610 mm) on center, and the fascia shall be inserted under the drip edge with at least 1 inch (305 mm) of fascia material covered by the drip edge. Where the fascia can not be inserted under the drip edge, the top edge of the fascia shall be secured using one finish nail [1 1/4 inches by 0.57 inch by 0.177 inch head diameter (32 mm × 14.5 mm × 4.5 mm)] located not more than 1 inch (25 mm) below the drip edge and spaced a maximum of 24 inches (610 mm) on center.</p>					
R704.4.1.2	Exterior Soffits and Facias	Provide specific direction for the installation of fascia at the eaves and rakes.	Increase, See RB237-22	NO	
<p>R704.4.1.2 Fascia installation where the design wind pressure exceeds 30 psf. Where the design wind pressure is greater than 30 pounds per square foot (1.44 kPa), aluminum fascia shall be attached with one finish nail [1 1/4 inches by 0.57 inch by 0.177 inch head diameter (32 mm × 14.5 mm × 4.5 mm)] in the return leg spaced a maximum of 16 inches (406 mm) on center and one finish nail located not more than 1 inch (25 mm) below the drip edge spaced a maximum of 16 inches (406 mm) on center. As an alternative, the top edge of the fascia is permitted to be secured using utility <i>trim</i> installed beneath the drip edge with snap locks punched into the fascia spaced not more than 6 inches (152 mm) on center.</p>					
R705.1	BIPV Systems For Exterior Wall Coverings and Fenestration	Requires that BIPV systems be listed and labeled in accordance with the applicable UL standards when used as exterior wall covering.	No	NO	
<p>SECTION R705 BIPV SYSTEMS FOR EXTERIOR WALL COVERINGS AND FENESTRATION R705.1 Listing required. In addition to complying with other provisions of this code, building-integrated photovoltaic (BIPV) systems used as <i>exterior wall coverings</i> or fenestration shall be <i>listed</i> and <i>labeled</i> in accordance with UL 1703 or both UL 61730-1 and UL 61730-2.</p>					
CHAPTER 8 ROOF-CEILING CONSTRUCTION					

2024 Code Section	TITLE OR SUBJECT	Reviewer Comments	Cost Yes/No	Amendment Needed Yes/No	TAG Comments/ Recommendation
R802.11	Wood Roof Framing	Addresses the potential use of wall framing of wood species having lower specific gravity than the value of 0.42	Increase, See RB247-22	NO	

R802.11 Roof tie uplift resistance.

Roof assemblies shall have uplift resistance in accordance with [Sections R802.11.1](#) and [R802.11.2](#).

Exceptions: Rafters or trusses shall be permitted to be attached to their supporting wall assemblies in accordance with [Table R602.3\(1\)](#) where either of the following occur:

1. 1.Where [the specific gravity of the wood species used for wall framing is greater than or equal to 0.42 in accordance with AWC NDS](#) and the uplift force per rafter or truss does not exceed 200 pounds (90.8 kg) as determined by [Table R802.11](#).
2. 2.Where the *basic wind speed* does not exceed 115 miles per hour (51.4 m/s), the wind exposure category is B, the roof pitch is 5 units vertical in 12 units horizontal (42-percent slope) or greater, the roof span is 32 feet (9754 mm) or less, and rafters and trusses are spaced not more than 24 inches (610 mm) on center.

2024 Code Section	TITLE OR SUBJECT	Reviewer Comments	Cost Yes/No	Amendment Needed Yes/No	TAG Comments/ Recommendation
R902.1	Fire Classification	Clarifies the section	No	NO	
<p>R902.1 Roof assemblies. Roof decks shall be covered with materials as set forth in Section R904 or with roof coverings as set forth in Section R905. Class A, B or C roof assemblies shall be installed in <i>jurisdictions</i> designated by law as requiring their use or where the edge of the roof deck is less than 3 feet (914 mm) from a <i>lot line</i>. Where Class A, B or C roof assemblies are required, they shall be tested in accordance with ASTM E108 or UL 790. Where required, the roof assembly shall be listed and identified as to class by an approved testing agency.</p> <p>Exceptions:</p> <ol style="list-style-type: none"> 1. 1.Class A roof assemblies include those with coverings of brick, masonry and exposed concrete roof deck. 2. 2.Class A roof assemblies include ferrous or copper shingles or sheets, metal sheets and shingles, clay or concrete roof tile, or slate installed on noncombustible roof decks. 3. 3.Class A roof assemblies include minimum 16 ounces per square foot (4.882 kg/m²) copper sheets installed over combustible roof decks. 4. 4.Class A roof assemblies include slate installed over underlayment over combustible roof decks. 					
R905.1.1	Requirements for Roof Coverings	Clarification and clean-up of Section R905.1.1 and Table R905.1.1(1) . BIPV are also added.	No	NO	
<p>R905.1.1 Underlayment. Underlayment in accordance with this section is required for asphalt shingles, clay and concrete tile, metal roof shingles, mineral-surfaced roll roofing, slate and slate-type shingles, wood shingles, wood shakes, metal roof panels and building-integrated photovoltaic (BIPV) roof coverings shall conform to the applicable standards listed in this chapter. Underlayment materials required to comply with ASTM D226; D1970; D2626; D4869; D6380, Class M; D6757; or D8257 shall bear a label indicating compliance to the standard designation and, if applicable, type classification indicated in Table R905.1.1(1). Underlayment shall be applied in accordance with Table R905.1.1(2). Underlayment shall be in accordance with Table R905.1.1(3). Exception: Structural metal panels that do not require a substrate or underlayment.</p>					

2024 Code Section	TITLE OR SUBJECT	Reviewer Comments	Cost Yes/No	Amendment Needed Yes/No	TAG Comments/ Recommendation
T R905.1.1	Requirements for Roof Coverings	Clarification and clean-up of Section R905.1.1 and Table R905.1.1(1) . BIPV are also added.	No	NO	

TABLE R905.1.1(1) UNDERLAYMENT TYPES

ROOF COVERING	SECTION	AREAS WHERE WIND DESIGN IS NOT REQUIRED IN ACCORDANCE WITH FIGURE R301.2.1.1	AREAS WHERE WIND DESIGN IS REQUIRED IN ACCORDANCE WITH FIGURE R301.2.1.1
Asphalt shingles	R905.2	ASTM D226 Type I or II ASTM D1970 ASTM D4869 Type I, II, III or IV ASTM D6757 ASTM D8257	ASTM D226 Type II ASTM D1970 ASTM D4869 Type III or IV ASTM D8257
Clay and concrete tile	R905.3	ASTM D226 Type II ASTM D1970 ASTM D2626 ASTM D6380 Class M ASTM D8257	ASTM D226 Type II ASTM D1970 ASTM D8257
Metal roof shingles	R905.4	ASTM D226 Type I or II ASTM D1970 ASTM D4869 Type I, II, III or IV ASTM D8257	ASTM D226 Type II ASTM D1970 ASTM D4869 Type III or IV ASTM D8257
Mineral-surfaced roll roofing	R905.5	ASTM D226 Type I or II ASTM D1970 ASTM D4869 Type I, II, III or IV ASTM D8257	ASTM D226 Type II ASTM D1970 ASTM D4869 Type III or IV ASTM D8257
Slate and slate-type shingles	R905.6	ASTM D226 Type I ASTM D1970 ASTM D4869 Type I, II, III or IV ASTM D8257	ASTM D226 Type II ASTM D1970 ASTM D4869 Type III or IV ASTM D8257
Wood shingles	R905.7	ASTM D226 Type I or II ASTM D4869 Type I, II, III or IV	ASTM D226 Type II ASTM D4869 Type III or IV
Wood shakes on solid sheathing	R905.8	ASTM D226 Type I or II ASTM D4869 Type I, II, III or IV	ASTM D226 Type II ASTM D4869 Type III or IV
Metal panels on solid sheathing	R905.10	ASTM D226 Type I or II ASTM D4869 Type I, II III or IV	ASTM D226 Type II ASTM D1970 ASTM D4869 Type III or IV ASTM D8257
BIPV roof coverings	R905.15	ASTM D226 Type I or II ASTM D1970 ASTM D4869 Type I, II, III or IV ASTM D6757 ASTM D8257	ASTM D226 Type II ASTM D1970 ASTM D4869 Type III or IV ASTM D8257

For St: 1 mile per hour = 0.447 m/s.

2024 Code Section	TITLE OR SUBJECT	Reviewer Comments	Cost Yes/No	Amendment Needed Yes/No	TAG Comments/ Recommendation
T R905.1.1(2)	Requirements for Roof Coverings	Modifies the language that is applicable to installation of a 2-layer underlayment system clarifying the Underlayment Lapping and Fastening in such a way that it reduces waste	No	NO	

TABLE R905.1.1(2) UNDERLAYMENT APPLICATION

ROOF COVERING	SECTION	AREAS WHERE WIND DESIGN IS NOT REQUIRED IN ACCORDANCE WITH FIGURE R901.2.1.1	AREAS WHERE WIND DESIGN IS REQUIRED IN ACCORDANCE WITH FIGURE R901.2.1.1
Asphalt shingles	R905.2	<p>Underlayment shall be one of the following:</p> <ol style="list-style-type: none"> For roof slopes from 2 units vertical in 12 units horizontal (2:12), up to 4 units vertical in 12 units horizontal (4:12), underlayment shall be two layers applied in the following manner: apply a strip of underlayment that is half the width of a full sheet parallel to and starting at the eaves, fastened sufficiently to hold in place. Starting at the eave, apply full-width sheets of underlayment, overlapping successive sheets half the width of a full sheet plus 2 inches. Distortions in the underlayment shall not interfere with the ability of the shingles to seal. End laps shall be 4 inches and shall be offset by 6 feet. For roof slopes of 4 units vertical in 12 units horizontal (4:12) or greater, underlayment shall be one layer applied in the following manner: underlayment shall be applied shingle fashion, parallel to and starting from the eave and lapped 2 inches. Distortions in the underlayment shall not interfere with the ability of the shingles to seal. End laps shall be 4 inches and shall be offset by 6 feet. A single layer of self-adhering polymer modified bitumen underlayment complying with ASTM D1970, installed in accordance with the underlayment and roof covering manufacturer's installation instructions for the deck material, roof ventilation configuration and climate exposure of the roof covering. 	<p>Underlayment shall be one of the following:</p> <ol style="list-style-type: none"> Two layers of mechanically fastened underlayment applied in the following manner: Apply a strip of underlayment that is half the width of a full sheet parallel to and starting at the eaves, fastened sufficiently to hold in place. Starting at the eave, apply full-width sheets of underlayment, overlapping successive sheets half the width of a full sheet plus 2 inches. Distortions in the underlayment shall not interfere with the ability of the shingles to seal. End laps shall be 4 inches and shall be offset by 6 feet. A minimum 4-inch-wide strip of self-adhering polymer modified bitumen underlayment complying with ASTM D1970, installed in accordance with the manufacturer's installation instructions for the deck material, shall be applied over all joints in the roof decking. An approved underlayment complying with Table R905.1.1(1) for the applicable roof covering shall be applied over the entire roof over the 4-inch-wide membrane strips. A single layer of self-adhering polymer modified bitumen underlayment complying with ASTM D1970, installed in accordance with the underlayment and roof covering manufacturer's installation instructions for the deck material, roof ventilation configuration and climate exposure of the roof covering.
Clay and concrete tile	R905.3	<p>Underlayment shall be one of the following:</p> <ol style="list-style-type: none"> For roof slopes from 2/3 units vertical in 12 units horizontal (2 2/3:12), up to 4 units vertical in 12 units horizontal (4:12), underlayment shall be two layers applied in the following manner: apply a strip of underlayment that is half the width of a full sheet parallel to and starting at the eaves, fastened sufficiently to hold in place. Starting at the eave, apply full-width sheets of underlayment, overlapping successive sheets half the width of a full sheet plus 2 inches. End laps shall be 4 inches and shall be offset by 6 feet. For roof slopes of 4 units vertical in 12 units horizontal (4:12) or greater, underlayment shall be one layer applied in the following manner: underlayment shall be applied shingle fashion, parallel to and starting from the eave and lapped 2 inches. End laps shall be 4 inches and shall be offset by 6 feet. A single layer of self-adhering polymer modified bitumen underlayment complying with ASTM D1970, installed in accordance with the underlayment and roof covering manufacturer's installation instructions for the deck material, roof ventilation configuration and climate exposure of the roof covering. 	<p>Underlayment shall be one of the following:</p> <ol style="list-style-type: none"> Two layers of mechanically fastened underlayment applied in the following manner: Apply a strip of underlayment felt that is half the width of a full sheet parallel to and starting at the eaves, fastened sufficiently to hold in place. Starting at the eave, apply full width sheets of underlayment, overlapping successive sheets half the width of a full sheet plus 2 inches. Distortions in the underlayment shall not interfere with the ability of the shingles to seal. End laps shall be 4 inches and shall be offset by 6 feet. A minimum 4-inch-wide strip of self-adhering polymer modified bitumen underlayment complying with ASTM D1970, installed in accordance with the manufacturer's installation instructions for the deck material, shall be applied over all joints in the roof decking. An approved underlayment complying with Table R905.1.1(1) for the applicable roof covering shall be applied over the entire roof over the 4-inch-wide membrane strips. A single layer of self-adhering polymer modified bitumen underlayment complying with ASTM D1970, installed in accordance with the underlayment and roof covering manufacturer's installation instructions for the deck material, roof ventilation configuration and climate exposure of the roof covering.

2024 Code Section	TITLE OR SUBJECT	Reviewer Comments	Cost Yes/No	Amendment Needed Yes/No	TAG Comments/ Recommendation
T R905.1.1(2) continued	Requirements for Roof Coverings	Modifies the language that is applicable to installation of a 2-layer underlayment system clarifying the Underlayment Lapping and Fastening in such a way that it reduces waste	No	NO	

2024 Code Section		TITLE OR SUBJECT	Reviewer Comments	Cost Yes/No	Amendment Needed Yes/No	TAG Comments/ Recommendation
Metal roof shingles	R905.4	Apply in accordance with the manufacturer's installation instructions.	Underlayment shall be one of the following: 1. Two layers of mechanically fastened underlayment applied in the following manner: Apply a strip of underlayment that is half the width of a full sheet parallel to and starting at the eaves, fastened sufficiently to hold in place. Starting at the eave, apply full width sheets of underlayment, overlapping successive sheets half the width of a full sheet plus 2 inches. End laps shall be 4 inches and shall be offset by 6 feet. 2. A minimum 4-inch-wide strip of self-adhering polymer modified bitumen underlayment complying with ASTM D1970 , installed in accordance with the manufacturer's installation instructions for the deck material, shall be applied over all joints in the roof decking. An approved underlayment complying with Table R905.1.1(1) for the applicable roof covering shall be applied over the entire roof over the 4-inch wide membrane strips. 3. A single layer of self-adhering polymer modified bitumen underlayment complying with ASTM D1970 , installed in accordance with the underlayment and roof covering manufacturer's installation instructions for the deck material, roof ventilation configuration and climate exposure of the roof covering.			
Mineral-surfaced roll roofing	R905.5					
Slate and slate-type shingles	R905.6					
Wood shingles	R905.7					
Wood shakes	R905.8					
Metal panels	R905.10					
BIPV roof coverings	R905.15	Underlayment shall be one of the following: 1. For roof slopes from 2 units vertical in 12 units horizontal (2:12), up to 4 units vertical in 12 units horizontal (4:12), underlayment shall be two layers applied in the following manner: apply a strip of underlayment that is half the width of a full sheet parallel to and starting at the eaves, fastened sufficiently to hold in place. Starting at the eave, apply full width sheets of underlayment, overlapping successive sheets half the width of a full sheet plus 2 inches. Distortions in the underlayment shall not interfere with the ability of the shingles to seal. End laps shall be 4 inches and shall be offset by 6 feet. 2. For roof slopes of 4 units vertical in 12 units horizontal (4:12) or greater, underlayment shall be one layer applied in the following manner: underlayment shall be applied shingle fashion, parallel to and starting from the eave and lapped 2 inches. Distortions in the underlayment shall not interfere with the ability of the shingles to seal. End laps shall be 4 inches and shall be offset by 6 feet. 3. A single layer of self-adhering polymer modified bitumen underlayment complying with ASTM D1970 , installed in accordance with the underlayment and roof covering manufacturer's installation instructions for the deck material, roof ventilation configuration and climate exposure of the roof covering.	Underlayment shall be one of the following: 1. Two layers of mechanically fastened underlayment applied in the following manner: Apply a strip of underlayment that is half the width of a full sheet parallel to and starting at the eaves, fastened sufficiently to hold in place. Starting at the eave, apply full width sheets of underlayment, overlapping successive sheets half the width of a full sheet plus 2 inches. Distortions in the underlayment shall not interfere with the ability of the shingles to seal. End laps shall be 4 inches and shall be offset by 6 feet. 2. A minimum 4-inch-wide strip of self-adhering polymer modified bitumen underlayment complying with ASTM D1970 , installed in accordance with the manufacturer's installation instructions for the deck material, shall be applied over all joints in the roof decking. An approved underlayment complying with Table R905.1.1(1) for the applicable roof covering shall be applied over the entire roof over the 4-inch wide membrane strips. 3. A single layer of self-adhering polymer modified bitumen underlayment complying with ASTM D1970 , installed in accordance with the underlayment and roof covering manufacturer's installation instructions for the deck material, roof ventilation configuration and climate exposure of the roof covering.			
For SI: 1 inch = 25.4 mm, 1 foot = 304.8 mm, 1 mile per hour = 0.447 m/s.						
T R905.1.1(3)		Requirements for Roof Coverings	Adds reference to manufacturers Installation reqs for self-adhering polymer modified bitumen underlayment	No	NO	

2024 Code Section	TITLE OR SUBJECT	Reviewer Comments	Cost Yes/No	Amendment Needed Yes/No	TAG Comments/ Recommendation																										
<p>TABLE R905.1.1(3) UNDERLAYMENT ATTACHMENT</p> <table border="1" data-bbox="212 329 1268 1011"> <thead> <tr> <th data-bbox="212 329 327 448">ROOF COVERING</th> <th data-bbox="327 329 411 448">SECTION</th> <th data-bbox="411 329 604 448">AREAS WHERE WIND DESIGN IS NOT REQUIRED IN ACCORDANCE WITH FIGURE R301.2.1.1</th> <th data-bbox="604 329 1268 448">AREAS WHERE WIND DESIGN IS REQUIRED IN ACCORDANCE WITH FIGURE R301.2.1.1</th> </tr> </thead> <tbody> <tr> <td data-bbox="212 448 327 532">Asphalt shingles</td> <td data-bbox="327 448 411 532">R905.2</td> <td data-bbox="411 448 604 699" rowspan="3">Fastened sufficiently to hold in place</td> <td data-bbox="604 448 1268 699" rowspan="3"> <p>Mechanically fastened underlayment shall be fastened with corrosion-resistant fasteners in a grid pattern of 12 inches between side laps with a 6-inch spacing at side and end laps. Underlayment shall be attached using annular ring or deformed shank nails with 1-inch-diameter metal or plastic caps. Metal caps shall have a thickness of not less than 32-gage sheet metal. Power-driven metal caps shall have a minimum thickness of 0.010 inch. Minimum thickness of the outside edge of plastic caps shall be 0.035 inch. The cap nail shank shall be not less than 0.083 inch. The cap nail shank shall have a length sufficient to penetrate through the roof sheathing or not less than $\frac{3}{4}$ inch into the roof sheathing.</p> <p>Self-adhering polymer modified bitumen underlayment shall be installed in accordance with the underlayment and roof covering manufacturers' installation instructions for the deck material, roof ventilation configuration, and climate exposure of the roof covering.</p> </td> </tr> <tr> <td data-bbox="212 532 327 617">Clay and concrete tile</td> <td data-bbox="327 532 411 617">R905.3</td> </tr> <tr> <td data-bbox="212 617 327 699"><i>BIPV roof covering</i></td> <td data-bbox="327 617 411 699">R905.15</td> </tr> <tr> <td data-bbox="212 699 327 751">Metal roof shingles</td> <td data-bbox="327 699 411 751">R905.4</td> <td data-bbox="411 699 604 1011" rowspan="6">Manufacturer's installation instructions.</td> <td data-bbox="604 699 1268 878" rowspan="6"> <p>Mechanically fastened underlayment shall be fastened with corrosion-resistant fasteners in a grid pattern of 12 inches between side laps with a 6-inch spacing at side and end laps. Underlayment shall be attached using annular ring or deformed shank nails with 1-inch-diameter metal or plastic caps. Metal caps shall have a thickness of not less than 32-gage sheet metal. Power-driven metal caps shall have a minimum thickness of 0.010 inch. Minimum thickness of the outside edge of plastic caps shall be 0.035 inch. The cap nail shank shall be not less than 0.083 inch. The cap nail shank shall have a length sufficient to penetrate through the roof sheathing or not less than $\frac{3}{4}$ inch into the roof sheathing.</p> <p>Self-adhering polymer modified bitumen underlayment shall be installed in accordance with the underlayment and roof covering manufacturers' installation instructions for the deck material, roof ventilation configuration and climate exposure of the roof covering.</p> </td> </tr> <tr> <td data-bbox="212 751 327 836">Mineral-surfaced roll roofing</td> <td data-bbox="327 751 411 836">R905.5</td> </tr> <tr> <td data-bbox="212 836 327 904">Slate and slate-type shingles</td> <td data-bbox="327 836 411 904">R905.6</td> </tr> <tr> <td data-bbox="212 904 327 956">Wood shingles</td> <td data-bbox="327 904 411 956">R905.7</td> </tr> <tr> <td data-bbox="212 956 327 982">Wood shakes</td> <td data-bbox="327 956 411 982">R905.8</td> </tr> <tr> <td data-bbox="212 982 327 1011">Metal panels</td> <td data-bbox="327 982 411 1011">R905.10</td> </tr> </tbody> </table> <p data-bbox="212 1036 527 1055">For SI: 1 inch = 25.4 mm, 1 mile per hour = 0.447 m/s.</p>						ROOF COVERING	SECTION	AREAS WHERE WIND DESIGN IS NOT REQUIRED IN ACCORDANCE WITH FIGURE R301.2.1.1	AREAS WHERE WIND DESIGN IS REQUIRED IN ACCORDANCE WITH FIGURE R301.2.1.1	Asphalt shingles	R905.2	Fastened sufficiently to hold in place	<p>Mechanically fastened underlayment shall be fastened with corrosion-resistant fasteners in a grid pattern of 12 inches between side laps with a 6-inch spacing at side and end laps. Underlayment shall be attached using annular ring or deformed shank nails with 1-inch-diameter metal or plastic caps. Metal caps shall have a thickness of not less than 32-gage sheet metal. Power-driven metal caps shall have a minimum thickness of 0.010 inch. Minimum thickness of the outside edge of plastic caps shall be 0.035 inch. The cap nail shank shall be not less than 0.083 inch. The cap nail shank shall have a length sufficient to penetrate through the roof sheathing or not less than $\frac{3}{4}$ inch into the roof sheathing.</p> <p>Self-adhering polymer modified bitumen underlayment shall be installed in accordance with the underlayment and roof covering manufacturers' installation instructions for the deck material, roof ventilation configuration, and climate exposure of the roof covering.</p>	Clay and concrete tile	R905.3	<i>BIPV roof covering</i>	R905.15	Metal roof shingles	R905.4	Manufacturer's installation instructions.	<p>Mechanically fastened underlayment shall be fastened with corrosion-resistant fasteners in a grid pattern of 12 inches between side laps with a 6-inch spacing at side and end laps. Underlayment shall be attached using annular ring or deformed shank nails with 1-inch-diameter metal or plastic caps. Metal caps shall have a thickness of not less than 32-gage sheet metal. Power-driven metal caps shall have a minimum thickness of 0.010 inch. Minimum thickness of the outside edge of plastic caps shall be 0.035 inch. The cap nail shank shall be not less than 0.083 inch. The cap nail shank shall have a length sufficient to penetrate through the roof sheathing or not less than $\frac{3}{4}$ inch into the roof sheathing.</p> <p>Self-adhering polymer modified bitumen underlayment shall be installed in accordance with the underlayment and roof covering manufacturers' installation instructions for the deck material, roof ventilation configuration and climate exposure of the roof covering.</p>	Mineral-surfaced roll roofing	R905.5	Slate and slate-type shingles	R905.6	Wood shingles	R905.7	Wood shakes	R905.8	Metal panels	R905.10
ROOF COVERING	SECTION	AREAS WHERE WIND DESIGN IS NOT REQUIRED IN ACCORDANCE WITH FIGURE R301.2.1.1	AREAS WHERE WIND DESIGN IS REQUIRED IN ACCORDANCE WITH FIGURE R301.2.1.1																												
Asphalt shingles	R905.2	Fastened sufficiently to hold in place	<p>Mechanically fastened underlayment shall be fastened with corrosion-resistant fasteners in a grid pattern of 12 inches between side laps with a 6-inch spacing at side and end laps. Underlayment shall be attached using annular ring or deformed shank nails with 1-inch-diameter metal or plastic caps. Metal caps shall have a thickness of not less than 32-gage sheet metal. Power-driven metal caps shall have a minimum thickness of 0.010 inch. Minimum thickness of the outside edge of plastic caps shall be 0.035 inch. The cap nail shank shall be not less than 0.083 inch. The cap nail shank shall have a length sufficient to penetrate through the roof sheathing or not less than $\frac{3}{4}$ inch into the roof sheathing.</p> <p>Self-adhering polymer modified bitumen underlayment shall be installed in accordance with the underlayment and roof covering manufacturers' installation instructions for the deck material, roof ventilation configuration, and climate exposure of the roof covering.</p>																												
Clay and concrete tile	R905.3																														
<i>BIPV roof covering</i>	R905.15																														
Metal roof shingles	R905.4	Manufacturer's installation instructions.	<p>Mechanically fastened underlayment shall be fastened with corrosion-resistant fasteners in a grid pattern of 12 inches between side laps with a 6-inch spacing at side and end laps. Underlayment shall be attached using annular ring or deformed shank nails with 1-inch-diameter metal or plastic caps. Metal caps shall have a thickness of not less than 32-gage sheet metal. Power-driven metal caps shall have a minimum thickness of 0.010 inch. Minimum thickness of the outside edge of plastic caps shall be 0.035 inch. The cap nail shank shall be not less than 0.083 inch. The cap nail shank shall have a length sufficient to penetrate through the roof sheathing or not less than $\frac{3}{4}$ inch into the roof sheathing.</p> <p>Self-adhering polymer modified bitumen underlayment shall be installed in accordance with the underlayment and roof covering manufacturers' installation instructions for the deck material, roof ventilation configuration and climate exposure of the roof covering.</p>																												
Mineral-surfaced roll roofing	R905.5																														
Slate and slate-type shingles	R905.6																														
Wood shingles	R905.7																														
Wood shakes	R905.8																														
Metal panels	R905.10																														
R905.3.6	Requirements For Roof Coverings	Intended to clarify the wind limitations in the IRC. Section R301.2.1.1 intends to limit the applicability of the IRC to	No	NO																											

2024 Code Section	TITLE OR SUBJECT	Reviewer Comments	Cost Yes/No	Amendment Needed Yes/No	TAG Comments/ Recommendation
		areas where wind design is not required.			
<p>R905.3.6 Wind resistance of concrete and clay tile. In regions where wind design is required in accordance with Figure R301.2.1.1, wind loads on concrete and clay tile shall be determined in accordance with Section 1504.3 of the <i>International Building Code</i>. In regions where wind design is not required in accordance with Figure R301.2.1.1, concrete and clay tiles shall be attached in accordance with Sections R905.3.8 and R905.3.9.</p>					
R905.5.6	Requirements For Roof Coverings	Intended to clarify the wind limitations in the IRC.	No	NO	
<p>R905.5.6 Wind resistance of mineral-surfaced roll roofing. Mineral-surfaced roll roofing shall be installed to resist the component and cladding loads specified in Table R301.2.1(1), adjusted for height and exposure in accordance with Table R301.2.1(2).</p>					
R905.6.5	Requirements For Roof Coverings	Intended to clarify the wind limitations in the IRC.	No	NO	
<p>R905.6.5 Wind resistance of slate shingles. Slate shingles shall be tested in accordance with ASTM D3161. Slate shingle packaging shall bear a <i>label</i> indicating compliance with ASTM D3161 and the required classification in Table R905.6.5.</p>					
T R905.6.5	Requirements For Roof Coverings	Provides building officials and users of the code guidance regarding the wind	No	NO	

2024 Code Section	TITLE OR SUBJECT	Reviewer Comments	Cost Yes/No	Amendment Needed Yes/No	TAG Comments/ Recommendation
		resistance of slate roof covings.			

TABLE R905.6.5 CLASSIFICATION OF SLATE SHINGLES TESTED IN ACCORDANCE WITH ASTM D3161

MAXIMUM ULTIMATE DESIGN WIND SPEED, V_{ult} , FROM FIGURE R301.2(2) (mph)	MAXIMUM BASIC WIND SPEED, V_{asdt} , FROM TABLE R301.2.1.3 (mph)	ASTM D3161 CLASSIFICATION
110	85	A, D or F
116	90	A, D or F
129	100	A, D or F
142	110	F
155	120	F
168	130	F
181	140	F
194	150	F

For SI: 1 mph=0.447 m/s

R905.7.1	Requirements For Roof Coverings	Some of the underlayment drying process occurs toward the interior. The exposure of this surface to the ventilation space is necessary to facilitate this process.	No	NO	
----------	---------------------------------	--	----	----	--

R905.7.1 Sheathing requirements.

Wood shingles shall be fastened to wood structural panels, solid lumber sheathing or spaced lumber sheathing. Where spaced lumber sheathing is used, sheathing boards shall be not less than 1-inch by 4-inch (25 mm by 102 mm) nominal dimensions and shall be spaced on centers equal to the weather exposure to coincide with the placement of fasteners. Where 1-inch by 4-inch (25 mm by 102 mm) spaced sheathing is installed at 10 inches (254 mm) or greater, additional 1-inch by 4-inch (25 mm by 102 mm) boards shall be installed between the sheathing boards. Where wood shingles are installed over spaced sheathing and the underside of the shingles are exposed to the attic space, the attic shall be ventilated in accordance with Sections R806.1, R806.2, R806.3 and R806.4. The shingles shall not be backed with materials that will occupy the required air gap space and prevent the free movement of air on the interior side of the spaced sheathing.

2024 Code Section	TITLE OR SUBJECT	Reviewer Comments	Cost Yes/No	Amendment Needed Yes/No	TAG Comments/ Recommendation
R905.7.5	Requirements For Roof Coverings	Intended to clarify the wind limitations in the IRC. Section R301.2.1.1 intends to limit the applicability of the IRC to areas where wind design is not required.	No	NO	
<p>R905.7.5 Wind resistance of wood shingles. In regions where wind design is required in accordance with Figure R301.2.1.1, wood shingles shall be installed to resist the component and cladding loads specified in Table R301.2.1(1), adjusted for height and exposure in accordance with Table R301.2.1(2). In regions where wind design is not required in accordance with Figure R301.2.1.1, wood shingles are permitted to be attached in accordance with Section R905.7.6.</p>					
R905.8.1	Requirements For Roof Coverings	Some of the underlayment drying process occurs toward the interior. The exposure of this surface to the ventilation space is necessary to facilitate this process.	No	NO	

2024 Code Section	TITLE OR SUBJECT	Reviewer Comments	Cost Yes/No	Amendment Needed Yes/No	TAG Comments/ Recommendation
<p>R905.8.1 Sheathing requirements. Wood shakes shall be fastened to wood structural panels, solid lumber sheathing or spaced lumber sheathing. Where spaced lumber sheathing is used, sheathing boards shall be not less than 1-inch by 4-inch (25 mm by 102 mm) nominal dimensions and shall be spaced on centers equal to the weather exposure to coincide with the placement of fasteners. Where 1-inch by 4-inch (25 mm by 102 mm) spaced lumber sheathing is installed at 10 inches (254 mm) on center, additional 1-inch by 4-inch (25 mm by 102 mm) boards shall be installed between the sheathing boards. Where wood shakes are installed over spaced sheathing and the underside of the shakes are exposed to the attic space, the attic shall be ventilated in accordance with Sections R806.1, R806.2, R806.3 and R806.4. The shakes shall not be backed with materials that will occupy the required air gap space and prevent the free movement of air on the interior side of the spaced sheathing.</p>					
R905.8.6	Requirements For Roof Coverings	Intended to clarify the wind limitations in the IRC. Section R301.2.1.1 intends to limit the applicability of the IRC to areas where wind design is not required.	No	NO	
<p>R905.8.6 Wind resistance of wood shakes. In regions where wind design is required in accordance with Figure R301.2.1.1, Wood shakes shall be installed to resist the component and cladding loads specified in Table R301.2.1(1), adjusted for height and exposure in accordance with Table R301.2.1(2). In regions where wind design is not required in accordance with Figure R301.2.1.1, wood shakes are permitted to be attached in accordance with Section R905.8.8.</p>					
R905.9.4	Requirements For Roof Coverings	Intended to clarify the wind limitations in the IRC.	No	NO	
<p>R905.9.4 Wind resistance of built-up roofs. Built-up roof coverings shall be tested in accordance with FM 4474, UL 580 or UL 1897 and installed to resist the component and cladding loads specified in Table R301.2.1(1), adjusted for height and exposure in accordance with Table R301.2.1(2).</p>					

2024 Code Section	TITLE OR SUBJECT	Reviewer Comments	Cost Yes/No	Amendment Needed Yes/No	TAG Comments/ Recommendation												
R905.10.5	Requirements For Roof Coverings	Intended to clarify the wind limitations in the IRC.	No	NO													
<p>R905.10.5 Wind resistance of metal roof panels. <i>Metal roof panels</i> shall be installed to resist the component and cladding loads specified in Table R301.2.1(1), adjusted for height and exposure in accordance with Table R301.2.1(2). <i>Metal roof panels</i> applied to a solid or closely fitted deck shall be tested for wind resistance in accordance with FM 4474, UL 580, or UL 1897. Structural standing seam metal panel roof systems shall be tested for wind resistance in accordance with ASTM E1592 or FM 4474. Structural through-fastened metal panel roof systems shall be tested for wind resistance in accordance with ASTM E1592, FM 4474 or UL 580.</p> <p>Exceptions:</p> <ol style="list-style-type: none"> 1. Metal roofs constructed of cold-formed steel shall be permitted to be designed and tested in accordance with the applicable referenced structural design standard in Section 2208.1 of the <i>International Building Code</i>. 2. Metal roofs constructed of aluminum shall be permitted to be designed and tested in accordance with the applicable referenced structural design standard in Section 2002.1 of the <i>International Building Code</i>. 																	
R905.11.4	Requirements For Roof Coverings	Intended to clarify the wind limitations in the IRC.	No	NO													
<p>R905.11.4 Wind resistance of modified bitumen roofing. Modified bitumen roofing shall be tested in accordance with FM 4474, UL 580 or UL 1897 and installed to resist the component and cladding loads specified in Table R301.2.1(1), adjusted for height and exposure in accordance with Table R301.2.1(2).</p>																	
T R905.12	Requirements For Roof Coverings	combines two existing sections, R905.12/R905.13 into a new section	No	NO													
<p>TABLE R905.12 SINGLE-PLY ROOFING MATERIAL STANDARDS</p> <table border="1"> <thead> <tr> <th>MATERIAL</th> <th>STANDARD</th> </tr> </thead> <tbody> <tr> <td>Chlorosulfanated polyethylene (CSPE) or polyisobutylene (PIB)</td> <td>ASTM D5019</td> </tr> <tr> <td>Ethylene propylene diene monomer (EPDM)</td> <td>ASTM D4637</td> </tr> <tr> <td>Ketone Ethylene Ester (KEE)</td> <td>ASTM D6754</td> </tr> <tr> <td>Polyvinyl chloride (PVC) or (PVC/KEE)</td> <td>ASTM D4434</td> </tr> <tr> <td>Thermoplastic polyolefin (TPO)</td> <td>ASTM D6878</td> </tr> </tbody> </table>						MATERIAL	STANDARD	Chlorosulfanated polyethylene (CSPE) or polyisobutylene (PIB)	ASTM D5019	Ethylene propylene diene monomer (EPDM)	ASTM D4637	Ketone Ethylene Ester (KEE)	ASTM D6754	Polyvinyl chloride (PVC) or (PVC/KEE)	ASTM D4434	Thermoplastic polyolefin (TPO)	ASTM D6878
MATERIAL	STANDARD																
Chlorosulfanated polyethylene (CSPE) or polyisobutylene (PIB)	ASTM D5019																
Ethylene propylene diene monomer (EPDM)	ASTM D4637																
Ketone Ethylene Ester (KEE)	ASTM D6754																
Polyvinyl chloride (PVC) or (PVC/KEE)	ASTM D4434																
Thermoplastic polyolefin (TPO)	ASTM D6878																

2024 Code Section	TITLE OR SUBJECT	Reviewer Comments	Cost Yes/No	Amendment Needed Yes/No	TAG Comments/ Recommendation
R905.12.4	Requirements For Roof Coverings	Intended to clarify the wind limitations in the IRC.	No	NO	
<p>R905.12.4 Wind resistance of single-ply roofing. Single-ply roofing shall be tested in accordance with FM 4474, UL 580 or UL 1897 and installed to resist the component and cladding loads specified in Table R301.2.1(1), adjusted for height and exposure in accordance with Table R301.2.1(2).</p>					
R905.13.4	Requirements For Roof Coverings	Intended to clarify the wind limitations in the IRC.	No	NO	
<p>R905.13.4 Wind resistance of sprayed polyurethane foam roofing. Sprayed polyurethane foam roofing shall be tested in accordance with FM 4474, UL 580 or UL 1897 and installed to resist the component and cladding loads specified in Table R301.2.1(1), adjusted for height and exposure in accordance with Table R301.2.1(2).</p>					
R905.14.4	Requirements For Roof Coverings	Intended to clarify the wind limitations in the IRC.	No	NO	
<p>R905.14.4 Wind resistance of liquid-applied roofing. Liquid-applied roofing shall be tested in accordance with FM 4474, UL 580 or UL 1897 and installed to resist the component and cladding loads specified in Table R301.2.1(1), adjusted for height and exposure in accordance with Table R301.2.1(2).</p>					
R905.16.7	Requirements For Roof Coverings	Intended to clarify the wind limitations in the IRC.	No	NO	
<p>R905.16.7 Wind resistance of BIPV roof panels. <i>BIPV roof panels</i> shall be tested in accordance with UL 7103 and installed to resist the component and cladding loads specified in Table R301.2.1(1), adjusted for height and exposure in accordance with Table R301.2.1(2).</p>					
R908.3	Reroofing	Provides specific requirements on acceptable methods for dealing with existing self-adhered membranes during a roof replacement.	Decrease, See RB281-22	NO	

2024 Code Section	TITLE OR SUBJECT	Reviewer Comments	Cost Yes/No	Amendment Needed Yes/No	TAG Comments/ Recommendation
	<p>R908.3 Roof replacement. <i>Roof replacement</i> shall include the removal of existing layers of <i>roof coverings</i> down to the <i>roof deck</i>.</p> <p>Exceptions:</p> <ol style="list-style-type: none"> 1. 1.Where the existing <i>roof assembly</i> includes an ice barrier membrane that is adhered to the <i>roof deck</i> and the existing sheathing is not water soaked or deteriorated to the point that it is not adequate as a base for additional roofing, the existing ice barrier membrane shall be permitted to remain in place and covered with an additional layer of ice barrier membrane in accordance with Section R905 where permitted by the roof covering manufacturer and new ice barrier underlayment manufacturer. 2. 2.Where the existing roof includes a self-adhered <i>underlayment</i> and the existing sheathing is not water soaked or deteriorated to the point that it is not adequate as a base for additional roofing, the existing self-adhered <i>underlayment</i> shall be permitted to remain in place and covered with an <i>underlayment</i> complying with Table R905.1.1(1), Table R905.1.1(2) and Table R905.1.1(3). 3. 3.Where the existing roof includes one layer of self-adhered <i>underlayment</i> and the existing layer cannot be removed without damaging the <i>roof deck</i>, a second layer of self-adhered <i>underlayment</i> is permitted to be installed over the existing self-adhered <i>underlayment</i> provided that the following conditions are met: <ol style="list-style-type: none"> 1. 3.1.It is permitted by the roof covering manufacturer and new self-adhered underlayment manufacturer. 2. 3.2.The existing sheathing is not water soaked or deteriorated to the point that it is not adequate as a base for additional roofing. 3. 3.3.The second layer of self-adhered <i>underlayment</i> is installed such that buildup of material at walls, valleys, roof edges, end laps, and side laps does not exceed two layers. 				
R908.4	Reroofing	Intended to Clarify Existing Code	No	NO	
	<p>R908.4 Roof recover. The installation of a new <i>roof covering</i> over an existing <i>roof covering</i> shall be permitted where any of the following conditions occur:</p> <ol style="list-style-type: none"> 1. 1.Where the new <i>roof covering</i> is installed in accordance with the roof covering manufacturer's <i>approved</i> instructions. 2. 2.Complete and separate roofing systems, such as standing-seam metal roof systems, that are designed to transmit the roof loads directly to the <i>building's</i> structural system and do not rely on existing roofs and <i>roof coverings</i> for support, shall not require the removal of existing <i>roof coverings</i>. 3. 3.Metal panel, metal shingle and concrete and clay tile <i>roof coverings</i> shall be permitted to be installed over existing wood shake roofs where applied in accordance with Section R908.4.1. 				

2024 Code Section	TITLE OR SUBJECT	Reviewer Comments	Cost Yes/No	Amendment Needed Yes/No	TAG Comments/ Recommendation
<p>4. 4.The application of a new protective <i>roof coating</i> over an existing protective <i>roof coating</i>, <i>metal roof panel</i>, <i>metal roof shingle</i>, mineral surfaced roll roofing, built-up roof, modified bitumen roofing, thermoset and thermoplastic single-ply roofing and spray polyurethane foam roofing system shall be permitted without tear-off of existing <i>roof coverings</i>.</p> <p>Exceptions: A <i>roof recover</i> shall not be permitted where any of the following conditions occur:</p> <ol style="list-style-type: none"> 1. 1.Where the existing roof or <i>roof covering</i> is water soaked or has deteriorated to the point that the existing roof or <i>roof covering</i> is not adequate as a base for the additional roofing. 2. 2.Where the existing <i>roof covering</i> is slate, clay, cement or asbestos-cement tile. 3. 3.Where the existing roof has two or more applications of any type of <i>roof covering</i>. 					
R909.1	Roof Coatings	provide specific requirements regarding the use of roof coating materials.	No	NO	
<p>SECTION R909 ROOF COATINGS R909.1 General. The installation of a <i>roof coating</i> on a <i>roof covering</i> shall comply with the requirements of Section R902, Section R904 and this section. <i>Roof coatings</i> shall be installed in accordance with the manufacturer's installation instructions.</p>					
R909.2	Roof Coatings	provide specific requirements regarding the use of roof coating materials.	No	NO	
<p>R909.2 Material standards. Roof coating materials shall comply with one of the standards in Table R909.2.</p>					
T R909.2	Roof Coatings	provide specific requirements regarding the use of roof coating materials.	No	NO	

2024 Code Section	TITLE OR SUBJECT	Reviewer Comments	Cost Yes/No	Amendment Needed Yes/No	TAG Comments/ Recommendation
-------------------	------------------	-------------------	----------------	-------------------------------	---------------------------------

TABLE R909.2 ROOF COATING MATERIAL STANDARDS

COATING MATERIAL	STANDARD
Acrylic coating	ASTM D6083
Asphaltic emulsion coating	ASTM D1227
Asphalt coating	ASTM D2823
Asphalt roof coating	ASTM D4479
Aluminum-pigmented asphalt coating	ASTM D2824
Silicone coating	ASTM D6694
Moisture-cured polyurethane coating	ASTM D6947

2024 Code Section	TITLE OR SUBJECT	Reviewer Comments	Cost Yes/No	Amendment Needed Yes/No	TAG Comments/ Recommendation
R1001.11	Masonry Fireplaces	A change in required dimensions	No	NO	

R1001.11 Fireplace clearance.

Wood beams, joists, studs and other *combustible material* shall have a clearance of not less than 2 inches (51 mm) from the front faces and sides of masonry fireplaces and not less than 4 inches (102 mm) from the back faces of masonry fireplaces. The airspace shall not be filled, except for [noncombustible material](#) or to provide *fireblocking* in accordance with [Section R1001.12](#).

Exceptions:

1. Masonry fireplaces *listed* and *labeled* for use in contact with combustibles in accordance with [UL 127](#) and installed in accordance with the manufacturer's instructions are permitted to have *combustible material* in contact with their exterior surfaces.
2. Where masonry fireplaces are part of masonry or concrete walls, *combustible materials* shall not be in contact with the masonry or concrete walls less than 12 inches (306 mm) from the inside surface of the nearest firebox lining.
3. Exposed combustible *trim* and the edges of sheathing materials such as wood siding, flooring and *gypsum board* shall be permitted to abut the masonry fireplace sidewalls and hearth extension in accordance with [Figure R1001.11](#), provided that such combustible *trim* or sheathing is not less than 8 inches (203 mm) from the inside surface of the nearest firebox lining. [Where the fireplace opening is 6 square feet \(0.6 m²\) or larger, such combustible trim or sheathing shall be permitted to abut the masonry fireplace sidewalls and hearth extension provided that such combustible trim or sheathing is not less than 12 inches \(305 mm\) from the inside surface of the nearest firebox lining.](#)
4. Exposed combustible mantels or *trim* is permitted to be placed directly on the masonry fireplace front surrounding the fireplace opening providing such *combustible materials* are not placed within 6 inches (152 mm) of a fireplace opening. *Combustible material* within 12 inches (306 mm) of the fireplace opening shall not project more than 1/8 inch (3 mm) for each 1-inch (25 mm) distance from such an opening.

2024 Code Section	TITLE OR SUBJECT	Reviewer Comments	Cost Yes/No	Amendment Needed Yes/No	TAG Comments/ Recommendation
R1003.18	Masonry Chimneys	Change from 12" to 8" in Exception 3 supported by 2013 Engineering Study	No	NO	

R1003.18 Chimney clearances.

Any portion of a *masonry chimney* located in the interior of the *building* or within the exterior wall of the *building* shall have a minimum airspace clearance to combustibles of 2 inches (51 mm). Chimneys located entirely outside the exterior walls of the *building*, including chimneys that pass through the soffit or cornice, shall have a minimum airspace clearance of 1 inch (25 mm). The airspace shall not be filled, except to provide fire blocking in accordance with [Section R1003.19](#).

Exceptions:

1. 1. *Masonry chimneys* equipped with a chimney lining system *listed* and *labeled* for use in chimneys in contact with combustibles in accordance with [UL 1777](#) and installed in accordance with the manufacturer's instructions are permitted to have *combustible material* in contact with their exterior surfaces.
2. 2. Where *masonry chimneys* are constructed as part of masonry or concrete walls, *combustible materials* shall not be in contact with the masonry or concrete wall less than **8 inches (203 mm)** from the inside surface of the nearest flue lining.
3. 3. *Combustible materials* shall be permitted to abut the *masonry chimney* side walls, in accordance with [Figure R1003.18](#), provided such combustible **material** is not less than 8 inches (203 mm) from the inside surface of the nearest flue lining.

2024 Code Section	TITLE OR SUBJECT	Reviewer Comments	Cost Yes/No	Amendment Needed Yes/No	TAG Comments/ Recommendation
CHAPTER 11 ENERGY EFFICIENCY					
Chapter 11 Not Adopted. Energy Code is Regulated by WAC 51-11R WSEC-R					

2024 Code Section	TITLE OR SUBJECT	Reviewer Comments	Cost Yes/No	Amendment Needed Yes/No	TAG Comments/ Recommendation
CHAPTER 12 MECHANICAL ADMINISTRATION					
No Significant Changes					

2024 Code Section	TITLE OR SUBJECT	Reviewer Comments	Cost Yes/No	Amendment Needed Yes/No	TAG Comments/ Recommendation
CHAPTER 13 GENERAL MECHANICAL SYSTEM REQUIREMENTS					
R1308.2.1	Mechanical Systems Installation	Reducing setback to 1 ¼ before a shield plate is required still keeps the pipes safely out of range of drywall screws up to 1-1/2 inches long	No	NO	
<p>M1308.2.1 Piping through bored holes or notches. Where <i>piping</i> is installed through holes or notches in framing members and is located less than 1¼ inches (32 mm) from the framing member face to which wall, ceiling or floor membranes will be attached, the pipe shall be protected by shield plates that cover the width of the pipe and the framing member and that extend 2 inches (51 mm) to each side of the framing member. Where the framing member that the piping passes through is a bottom plate, bottom track, top plate or top track, the shield plates shall cover the framing member and extend 2 inches (51 mm) above the bottom framing member and 2 inches (51 mm) below the top framing member.</p>					
R1308.2.2	Mechanical Systems Installation	Reducing setback to 1 ¼ before a shield plate is required still keeps the pipes safely out of range of drywall screws up to 1-1/2 inches long	No	NO	

2024 Code Section	TITLE OR SUBJECT	Reviewer Comments	Cost Yes/No	Amendment Needed Yes/No	TAG Comments/ Recommendation
<p>M1308.2.2 Piping in other locations. Where piping is located within a framing member and is less than 1¹/₄ inches (32 mm) from the framing member face to which wall, ceiling or floor membranes will be attached, the piping shall be protected by shield plates that cover the width and length of the piping. Where piping is located outside of a framing member and is located less than 1¹/₂ inches (38 mm) from the nearest edge of the face of the framing member to which the membrane will be attached, the piping shall be protected by shield plates that cover the width and length of the piping.</p>					
CHAPTER 14 HEATING AND COOLING EQUIPMENT AND APPLIANCES					
M1402.1	Central Furnaces	Updates Standards to most Current	No	NO	
<p>M1402.1 General. Oil-fired central furnaces shall <i>be listed and labeled in accordance with UL 727</i>. Electric <i>furnaces</i> shall <i>be listed and labeled in accordance with UL 1995 or UL/CSA 60335-2-40</i>.</p>					
M1404.1	Refrigeration Cooling Equipment	Adds Appropriate Standards that Regulate refrigeration cooling equipment	No	NO	
<p>M1404.1 Compliance. Refrigeration cooling <i>equipment</i> shall <i>be listed and labeled in accordance with UL 484, UL 1995 or UL/CSA 60335-2-40</i> .</p>					
M1411.2	Heating and Cooling Equipment	Adds requirements consistent with the provisions in ASHRAE 15.2.	No	NO	
<p>M1411.2 Refrigeration system listing. Refrigeration systems using Group A2L refrigerants shall <i>be listed and labeled to UL/CSA 60335-2-40</i>. Refrigeration systems using Group A1 refrigerants shall <i>be listed to UL/CSA 60335-2-40 or UL 1995</i>. The equipment shall be installed in accordance with the listing.</p>					

2024 Code Section	TITLE OR SUBJECT	Reviewer Comments	Cost Yes/No	Amendment Needed Yes/No	TAG Comments/ Recommendation
M1411.3	Heating and Cooling Equipment	Adds requirements consistent with the provisions in ASHRAE 15.2.	No	NO	
<p>M 1411.3 Refrigeration system installation. Refrigeration systems shall be installed in accordance with the manufacturer's installation instructions. After installation, the manufacturer's installation instructions, owner's manuals, service manuals and any other product literature provided with the equipment shall be attached to the indoor unit or left with the homeowner.</p>					
M1411.4	Heating and Cooling Equipment	Adds requirements consistent with the provisions in ASHRAE 15.2.	No	NO	
<p>M1411.4 Field-installed accessories. Field-installed accessories shall be installed in accordance with the accessory and equipment manufacturer's installation instructions. Accessories installed in the ductwork of Group A2L refrigeration systems shall not contain electric heating elements, open flames, or devices switching electrical loads greater than 2.5 kVA.</p>					
M1411.5	Heating and Cooling Equipment	Adds requirements consistent with the provisions in ASHRAE 15.2.	No	NO	
<p>M1411.5 Signs and identification. Each refrigeration system using Group A2L refrigerant shall have the following information legibly and permanently indicated on a markable label provided by the equipment manufacturer.</p> <ol style="list-style-type: none"> 1.Contact information of the responsible company that installed the refrigeration system. 2.The system refrigerant charge and the refrigerant number. 					
M1411.6	Heating and Cooling Equipment	Adds requirements consistent with the provisions in ASHRAE 15.2.	No	NO	
<p>M1411.6 Refrigerant charge. Refrigeration systems shall have refrigerant charge in compliance with the equipment manufacturer's installation instructions and the requirements of the listing. Group A2L refrigerant charge for an individual refrigeration system shall not exceed 34.5 pounds (15.7 kg).</p>					

2024 Code Section	TITLE OR SUBJECT	Reviewer Comments	Cost Yes/No	Amendment Needed Yes/No	TAG Comments/ Recommendation
M1411.7	Heating and Cooling Equipment	Adds requirements consistent with the provisions in ASHRAE 15.2.	No	NO	
<p>M1411.7 Group A2L refrigerant piping testing. The piping system containing Group A2L refrigerant shall be tested in accordance with the manufacturer's installation instructions and the requirements of the listing.</p>					
CHAPTER 15 EXHAUST SYSTEMS					
M1502.6	Clothes Dryer Exhaust	Establishes minimum and reasonable requirements for clothes dryer makeup air.	No	NO	
<p>M1502.6 Makeup air. Installations exhausting more than 200 cubic feet per minute (0.09 m³/s) shall be provided with makeup air.</p>					
M1502.6.1	Clothes Dryer Exhaust	Clarifies that transfer air can be used to meet makeup air requirements for clothes dryers in closets or that makeup air could be directly ducted from the outdoors to the clothes dryer closet.	No	NO	
<p>M1502.6.1 Closet installation.</p>					

2024 Code Section	TITLE OR SUBJECT	Reviewer Comments	Cost Yes/No	Amendment Needed Yes/No	TAG Comments/ Recommendation
<p>Where a <i>closet</i> is designed for the installation of a clothes dryer, makeup air shall be provided in accordance with the dryer manufacturer's installation instructions. If the manufacturer's installation instructions do not include specifications for provision of makeup air, one or more permanent openings having a total area of not less than 100 square inches (645 mm²) shall be provided in the <i>closet enclosure</i>, or makeup air shall be provided by other <i>approved means</i>.</p>					
M1503.5	Domestic Cooking Exhaust Equipment	Editorial, local exhaust rates for kitchens and bathrooms moved out from whole house mechanical ventilation	No	YES, Modify Existing Amendment	
<p>M1503.5 Kitchen exhaust rates. Where domestic <i>kitchen cooking appliances</i> are equipped with ducted range hoods or down-draft exhaust systems, <i>the exhaust rate shall equal or exceed the airflow required in Table M1505.5 at one or more speed settings.</i></p>					
M1503.6	Domestic Cooking Exhaust Equipment	Clarifies a minimum of one outdoor air duct is required in a kitchen makeup air system.	No	NO	
<p>M1503.6 Makeup air required. Where one or more gas, liquid or solid fuel-burning <i>appliance</i> that is neither direct-vent nor uses a <i>mechanical draft</i> venting system is located within a <i>dwelling unit's air barrier</i>, each exhaust system capable of exhausting in excess of 400 cubic feet per minute (0.19 m³/s) shall be mechanically or passively provided with makeup air at a rate approximately equal to the exhaust air rate. Such makeup air systems shall be equipped with not fewer than one <i>outdoor air duct and damper</i> complying with <i>Section M1503.6.2</i>. Exception: Makeup air is not required for exhaust systems installed for the exclusive purpose of space cooling and intended to be operated only when windows or other air inlets are open.</p>					
M15003.6.1	Domestic Cooking Exhaust Equipment	Clarifies a minimum of one outdoor air duct is required in a kitchen makeup air system.	No	NO	

2024 Code Section	TITLE OR SUBJECT	Reviewer Comments	Cost Yes/No	Amendment Needed Yes/No	TAG Comments/ Recommendation
<p>M1503.6.1 Location. <i>Kitchen</i> exhaust makeup air that is ducted from the outdoors shall be discharged into the same room in which the exhaust system is located or into rooms or <i>duct systems</i> that communicate through one or more permanent openings with the room in which such exhaust system is located. Such permanent openings shall have a net cross-sectional area not less than the required area of the makeup air supply openings.</p>					
M1504.3	Exhaust Ducts and Exhaust Openings	Clarifies location for combination Intake/Exhaust vents. Reduces materials and labor expense required to offset exhaust duct terminations away from windows.	Decrease, See RM13-21	NO	
<p>M1504.3 Exhaust openings. Air exhaust openings shall terminate as follows:</p> <ol style="list-style-type: none"> 1. Not less than 3 feet (914 mm) from property lines. 2. Not less than 3 feet (914 mm) from gravity air intake openings, operable windows and doors except where the exhaust opening is located not less than 1 foot (305 mm) above the gravity air intake opening, operable windows and doors. 3. Not less than 10 feet (3048 mm) from mechanical air intake openings except where either of the following apply: <ol style="list-style-type: none"> 3.1. The exhaust opening is located not less than 3 feet (914 mm) above the air intake opening. 					

2024 Code Section	TITLE OR SUBJECT	Reviewer Comments	Cost Yes/No	Amendment Needed Yes/No	TAG Comments/ Recommendation
<p style="text-align: center;">3.2.The exhaust opening is part of a factory-built intake/exhaust combination termination fitting installed in accordance with the fan manufacturer's instructions, and the exhaust air is drawn from a <i>living space</i>.</p> <p style="text-align: center;">4.In accordance with Sections R303.5.2 and R303.6.</p>					
M1505.5	Mechanical Ventilation	Footnote a. moved to the main section from T R1505.5 To ensure that builders are selecting fans that can be expected to achieve the required 50 cfm in the field.	No	NO	
<p>M1505.5 Local exhaust rates. <i>Local exhaust</i> systems shall be designed to have the capacity to exhaust the minimum airflow rate determined in accordance with Table M1505.5 at one or more speed settings. The <i>listed</i> exhaust airflow rate for a bathroom or toilet room exhaust fan shall equal or exceed the exhaust airflow rate in Table M1505.5 at a minimum static pressure of 0.25 inch wc at one or more speed settings in accordance with Section M1505.3.</p>					
CHAPTER 16 DUCT SYSTEMS					
M 1602.2	Return Air	Allowing a limited amount of return air provides a means of controlling closet moisture levels.	Increase, See RM19-21	NO	

2024 Code Section	TITLE OR SUBJECT	Reviewer Comments	Cost Yes/No	Amendment Needed Yes/No	TAG Comments/ Recommendation
	<p>M1602.2 Return air openings.</p> <p>Return air openings for heating, <i>ventilation</i> and air-conditioning systems shall comply with all of the following:</p> <ol style="list-style-type: none"> 1. Openings shall not be located less than 10 feet (3048 mm) measured in any direction from an open combustion chamber or draft hood of another <i>appliance</i> located in the same room or space. 2. The amount of return air taken from any room or space except mechanical rooms, boiler rooms or furnace rooms shall be not greater than the flow rate of supply air delivered to such room or space. Return air taken from mechanical rooms, boiler rooms or furnace rooms shall serve only the mechanical room and shall be permitted to be taken from mechanical rooms that have no dedicated supply duct. 3. Return and transfer openings shall be sized in accordance with the <i>appliance</i> or equipment manufacturer's installation instructions, <u>Manual D</u> or the design of the <i>registered design professional</i>. 4. Where return air is taken from a mechanical room, boiler room or furnace room with combustion appliances, only sealed combustion appliances shall be permitted within the mechanical room. 5. Where return air is taken from a mechanical room, boiler room or furnace room, the pressure differential across the mechanical room, boiler room or furnace room door shall be limited to 0.01 inch wc (2.5 pascals) or less by undercutting the door, or installing a louvered door or transfer grille, or by some other means. 6. Where return air is taken from a closet, the return air shall be not more than 30 cubic feet per minute (15 l/s), shall serve only the closet and shall not require a dedicated supply duct, and the closet door shall be undercut not less than 1.5 inches (38 mm) or the closet shall include a louvered door or transfer grille with a net free area of not less than 30 square inches (194 cm²). 7. Return air shall not be taken from a <i>closet</i>, toilet room, <i>kitchen</i>, garage, or unconditioned <i>attic</i>. <p>Exceptions:</p> <ol style="list-style-type: none"> 1. Taking return air from a <i>kitchen</i> is not prohibited where such return air openings serve the <i>kitchen</i> only, and are located not less than 10 feet (3048 mm) from the cooking <i>appliances</i>. 2. Dedicated forced-air systems serving only the garage shall not be prohibited from obtaining return air from the garage. 3. Return air taken from closets shall serve only the closet and shall be permitted to be taken from closets that have no dedicated supply duct. 8. For other than dedicated HVAC systems, return air shall not be taken from indoor swimming pool enclosures and associated deck areas except where the air in such spaces is dehumidified. 9. Taking return air from an unconditioned <i>crawl space</i> shall not be accomplished through a direct connection to the return side of a forced-air furnace. Transfer openings in the <i>crawl space</i> enclosure shall not be prohibited. 10. Return air from one dwelling unit shall not be discharged into another dwelling unit. 				
CHAPTER 17 COMBUSTION AIR					

2024 Code Section	TITLE OR SUBJECT	Reviewer Comments	Cost Yes/No	Amendment Needed Yes/No	TAG Comments/ Recommendation
No Significant Changes in Chapter 17					

2024 Code Section	TITLE OR SUBJECT	Reviewer Comments	Cost Yes/No	Amendment Needed Yes/No	TAG Comments/ Recommendation
CHAPTER 18 CHIMNEYS AND VENTS					
No Significant Changes in Chapter 18					

2024 Code Section	TITLE OR SUBJECT	Reviewer Comments	Cost Yes/No	Amendment Needed Yes/No	TAG Comments/ Recommendation
CHAPTER 19 SPECIAL APPLIANCES, EQUIPMENT AND SYSTEMS					
No Significant Changes in Chapter 19					

2024 Code Section	TITLE OR SUBJECT	Reviewer Comments	Cost Yes/No	Amendment Needed Yes/No	TAG Comments/ Recommendation
CHAPTER 20 BOILERS AND WATER HEATERS					
M2002.4.1	Water Heaters Used for Space Heating	Correlates discharge piping reqs in the IMC	No	NO	
<p>M2002.4.1 Requirements for discharge pipe.</p> <p>The discharge piping serving a pressure relief valve, temperature relief valve or combination valve shall:</p> <ol style="list-style-type: none"> 1. 1. Not be directly connected to the drainage system. 2. 2. Discharge through an <i>air break</i> located in the same room as the boiler. 3. 3. Not be smaller than the diameter of the outlet of the valve served and shall discharge full size to the air break. 4. 4. Serve a single relief device and shall not connect to piping serving any other relief device or <i>equipment</i>. 5. 5. Discharge to the floor, to the pan serving the boiler or storage tank, to a waste receptor or to the outdoors. 6. 6. Discharge in a manner that does not cause personal injury or structural damage. 7. 7. Discharge to a termination point that is readily observable by the building occupants. 8. 8. Not be trapped. 9. 9. Be installed to flow by gravity. 10. 10. Terminate not more than 6 inches (152 mm) above the floor or waste receptor <i>flood level rim</i>. 11. 11. Not have a threaded connection at the end of the piping. 12. 12. Not have valves or tee fittings. 13. 13. Be constructed of those materials indicated in Section P2906.5 or materials tested, rated and <i>approved</i> for such use in accordance with ASME A112.4.1. 					

2024 Code Section	TITLE OR SUBJECT	Reviewer Comments	Cost Yes/No	Amendment Needed Yes/No	TAG Comments/ Recommendation
CHAPTER 21 HYDRONIC PIPING					
T M2101.1	Hydronic Piping Systems Installation	Adds Standards for PEX Fittings to Table AASTM F3347 / ASTM F3348	No	NO	

2024 Code Section	TITLE OR SUBJECT	Reviewer Comments	Cost Yes/No	Amendment Needed Yes/No	TAG Comments/ Recommendation
-------------------	------------------	-------------------	-------------	-------------------------	------------------------------

TABLE M2101.1HYDRONIC PIPING AND FITTING MATERIALS

MATERIAL	USE CODE ^a	STANDARD ^b	JOINTS	NOTES
Acrylonitrile butadiene styrene (ABS) plastic pipe	1, 5	ASTM D1527 , ASTM F2806 , ASTM F2969	Solvent cement joints	—
Chlorinated poly (vinyl chloride) (CPVC) pipe and tubing	1, 2, 3	ASTM D2846	Solvent cement joints, compression joints and threaded adapters	—
Copper and copper-alloy pipe	1	ASTM B42 , ASTM B43 , ASTM B302	Brazed, soldered and mechanical fittings threaded, welded and flanged	—
Copper and copper-alloy tubing (Type K, L or M)	1, 2	ASME B16.51 , ASTM B75 , ASTM B88 , ASTM B135 , ASTM B251 , ASTM B306	Brazed, soldered, press-connected and flared mechanical fittings	Joints embedded in concrete shall be brazed
Cross-linked polyethylene (PEX)	1, 2, 3	ASTM F876 , ASTM F3253	(See PEX fittings)	Install in accordance with manufacturer's instructions
Cross-linked polyethylene/aluminum/cross-linked polyethylene (PEX-AL-PEX) pressure pipe	1, 2	ASTM F1281 or CAN/CSA B137.10	Mechanical, crimp/insert	Install in accordance with manufacturer's instructions
PEX fittings	—	ASTM F877 , ASTM F1807 , ASTM F1960 , ASTM F2098 , ASTM F2159 , ASTM F2735 , ASTM F3253 , ASTM F3347 , ASTM F3348	Copper crimp/insert fittings, cold expansion fittings, stainless steel clamp, insert fittings	Install in accordance with manufacturer's instructions
Polybutylene (PB) pipe and tubing	1, 2, 3	ASTM D3309	Heat-fusion, crimp/insert and compression	Joints in concrete shall be heat-fused
Polyethylene/aluminum/polyethylene (PE-AL-PE) pressure pipe	1, 2, 3	ASTM F1282 , CSA B137.9	Mechanical, crimp/insert	—
Polypropylene (PP)	1, 2, 3	ISO 15874 , ASTM F2389	Heat-fusion joints, mechanical fittings, threaded adapters, compression joints	—
Raised temperature polyethylene (PE-RT)	1, 2, 3	ASTM F2623 , ASTM F2769 , CSA B137.18	Copper crimp/insert fitting, stainless steel clamp, insert fittings	—
Raised temperature polyethylene (PE-RT) fittings	1, 2, 3	ASTM D3261 , ASTM F1807 , ASTM F2098 , ASTM F2159 , ASTM F2735 , ASTM F2769 , ASTM F3347 , ASTM F3348 , CSA B137.18	Copper crimp/insert fitting, stainless steel clamp, insert fittings	—
Steel pipe	1, 2	ASTM A53 , ASTM A106	Brazed, welded, threaded, flanged and mechanical fittings	Joints in concrete shall be welded. Galvanized pipe shall not be welded or brazed.
Steel tubing	1	ASTM A254	Mechanical fittings, welded	—

For St: °C = [(°F) - 32]/1.8.

a. Use code:

1. Above ground.
2. Embedded in radiant systems.
3. Temperatures below 180°F only.
4. Low-temperature (below 130°F) applications only.
5. Temperatures below 160°F only.

b. Standards as listed in [Chapter 44](#).

CHAPTER 22 SPECIAL PIPING AND STORAGE SYSTEMS

2024 Code Section	TITLE OR SUBJECT	Reviewer Comments	Cost Yes/No	Amendment Needed Yes/No	TAG Comments/ Recommendation
No Significant Changes in Chapter 22					
CHAPTER 23 SOLAR THERMAL ENERGY SYSTEMS					

2024 Code Section	TITLE OR SUBJECT	Reviewer Comments	Cost Yes/No	Amendment Needed Yes/No	TAG Comments/ Recommendation
No Significant Changes in Chapter 23					
CHAPTER 24 FUEL GAS					

2024 Code Section	TITLE OR SUBJECT	Reviewer Comments	Cost Yes/No	Amendment Needed Yes/No	TAG Comments/ Recommendation
G2407.12	Combustion, Ventilation and Dilution Air	Protects occupants from contaminated air	No	NO	
<p>G2407.12 (304.12)Protection from fumes and gases. Where chemicals that generate corrosive or flammable products such as aerosol sprays are routinely used, one of the following shall apply to fired <i>appliances</i> where these chemicals can enter combustion air:</p> <ol style="list-style-type: none"> 1.Fired appliances shall be located in a mechanical room separate or partitioned off from other areas with provisions for combustion and dilution air from outdoors. 2.The appliances shall be direct vent and installed in accordance with the appliance manufacturer’s installation instructions. 					
G2417.7.3.1	Inspection, Testing and Purging	Prevents hazardous conditions to exist on decommissioned systems	No	NO	
<p>G2417.7.3.1 (406.7.3.1)Abandoned fuel gas piping. Where <i>fuel gas</i> piping is removed from service for an indefinite time period, it shall be <i>purged</i>.</p>					
CHAPTER 25 PLUMBING ADMINISTRATION					

2024 Code Section	TITLE OR SUBJECT	Reviewer Comments	Cost Yes/No	Amendment Needed Yes/No	TAG Comments/ Recommendation
		This Chapter is not adopted per WAC 51-51-003. For Plumbing Provisions, see WAC 51-56 . Adoption and Amendment of the Uniform Plumbing Code.			
CHAPTER 26 GENERAL PLUMBING REQUIREMENTS					
		This Chapter is not adopted per WAC 51-51-003. For Plumbing Provisions, see WAC 51-56 . Adoption and Amendment of the Uniform Plumbing Code.			
CHAPTER 27 PLUMBING FIXTURES					
		This Chapter is not adopted per WAC 51-51-003. For Plumbing Provisions, see WAC 51-56 . Adoption and Amendment of the Uniform Plumbing Code.			
CHAPTER 28 WATER HEATERS					
		This Chapter is not adopted per WAC 51-51-003. For Plumbing Provisions, see WAC 51-56 . Adoption and Amendment of the Uniform Plumbing Code.			
CHAPTER 29 WATER SUPPLY AND DISTRIBUTION					
		This Chapter is not adopted per WAC 51-51-003. For Plumbing Provisions, see WAC 51-56 . Adoption and Amendment of the Uniform Plumbing Code.			
CHAPTER 30 SANITARY DRAINAGE					
		This Chapter is not adopted per WAC 51-51-003. For Plumbing Provisions, see WAC 51-56 . Adoption and Amendment of the Uniform Plumbing Code.			
CHAPTER 31 VENTS					
		This Chapter is not adopted per WAC 51-51-003. For Plumbing Provisions, see WAC 51-56 . Adoption and Amendment of the Uniform Plumbing Code.			
CHAPTER 32 TRAPS					
		This Chapter is not adopted per WAC 51-51-003. For Plumbing Provisions, see WAC 51-56 . Adoption and Amendment of the Uniform Plumbing Code.			
CHAPTER 33 STORM DRAINAGE					
		This Chapter is not adopted per WAC 51-51-003. For Plumbing Provisions, see WAC 51-56 . Adoption and Amendment of the Uniform Plumbing Code.			
CHAPTER 34 GENERAL REQUIREMENTS					
		This Chapter is not adopted per WAC 51-51-003. For Electrical Provisions, see WAC 296-46B . Adoption of the National Electric Code.			
CHAPTER 35 ELECTRICAL DEFINITIONS					
		This Chapter is not adopted per WAC 51-51-003. For Electrical Provisions, see WAC 296-46B . Adoption of the National Electric Code.			
CHAPTER 36 SERVICES					
		This Chapter is not adopted per WAC 51-51-003. For Electrical Provisions, see WAC 296-46B . Adoption of the National Electric Code.			
CHAPTER 37 BRANCH CIRCUIT AND FEEDER REQUIREMENTS					
		This Chapter is not adopted per WAC 51-51-003. For Electrical Provisions, see WAC 296-46B . Adoption of the National Electric Code.			

2024 Code Section	TITLE OR SUBJECT	Reviewer Comments	Cost Yes/No	Amendment Needed Yes/No	TAG Comments/ Recommendation
CHAPTER 38 WIRING METHODS					
This Chapter is not adopted per WAC 51-51-003. For Electrical Provisions, see WAC 296-46B . Adoption of the National Electric Code.					
CHAPTER 39 POWER AND LIGHTING DISTRIBUTION					
This Chapter is not adopted per WAC 51-51-003. For Electrical Provisions, see WAC 296-46B . Adoption of the National Electric Code.					
CHAPTER 40 DEVICES AND LUMINARIES					
This Chapter is not adopted per WAC 51-51-003. For Electrical Provisions, see WAC 296-46B . Adoption of the National Electric Code.					
CHAPTER 41 APPLIANCE INSTALLATION					
This Chapter is not adopted per WAC 51-51-003. For Electrical Provisions, see WAC 296-46B . Adoption of the National Electric Code.					
CHAPTER 42 SWIMMING POOLS					
This Chapter is not adopted per WAC 51-51-003. For Electrical Provisions, see WAC 296-46B . Adoption of the National Electric Code.					
CHAPTER 43 CLASS 2 REMOTE-CONTROL, SIGNALING AND POWER-LIMITED CIRCUITS					

2024 Code Section	TITLE OR SUBJECT	Reviewer Comments	Cost Yes/No	Amendment Needed Yes/No	TAG Comments/ Recommendation
<p>This Chapter is not adopted per WAC 51-51-003. For Electrical Provisions, see WAC 296-46B. Adoption of the National Electric Code.</p>					
CHAPTER 44 REFERENCED STANDARDS					
ABTG	APPLIED BUILDING TECHNOLOGY GROUP			NO	
<p>ABTG <i>Applied Building Technology Group LLC 6300 Enterprise Lane Madison, WI 53719</i> ANSI/ABTG FS 100—2012 (R2018): Standard Requirements for Wind Pressure Resistance of Foam Plastic Insulation Sheathing Used in Exterior Wall Covering Assemblies R303.8</p>					
ACCA	Air Conditioning Contractors of Amer.			NO	

2024 Code Section	TITLE OR SUBJECT	Reviewer Comments	Cost Yes/No	Amendment Needed Yes/No	TAG Comments/ Recommendation
ACCA <i>Air Conditioning Contractors of America 1330 Braddock Place, Suite 350 Alexandria, VA 22314</i> ANSI/ACCA 1 Manual D—2023: Residential Duct Systems N1103.3.1 , Table R301.2 , M1601.1, M1602.2 ANSI/ACCA 2 Manual J—2016: Residential Load Calculation Table R301.2 , N1103.7 , M1401.3 ANSI/ACCA 3 Manual S—2023: Residential Equipment Selection N1103.7 , M1401.3, ANSI/ACCA 5 QI—2010: HVAC Quality Installation Specification N1108.2.4					
AHRI	Air Condition, Heating & Refrigeration			NO	
AHRI <i>Air-Conditioning, Heating, & Refrigeration Institute 2111 Wilson Blvd, Suite 500 Arlington, VA 22201</i> AHRI 1380—2019: Demand Response through Variable Capacity HVAC Systems in Residential and Small Commercial Applications N1108.2.8.2					
ALI	Automotive Lift Inst.			NO	
ALI <i>Automotive Lift Institute, Inc. PO Box 85 Cortland, NY 13045</i> ALI ALCTV—2017: Standard for Automotive Lifts—Safety Requirements for Construction, Testing and Validation (ANSI) R317.7					
AMCA	Air Movement and Control Assoc.			NO	
AMCA <i>Air Movement and Control Association International 30 West University Drive Arlington Heights, IL 60004</i> ANSI/AMCA 210- Laboratory Methods of Testing Fans for Aerodynamic Performance Rating ANSI/ASHRAE 51—23 Table N1103.6.2 , Table M1504.2 , M1505.3					
ANSI	American National Standards Inst.	See Existing Amendment Report		Modify Existing Amendment	
A108.1A—17 Installation of Ceramic Tile in the Wet-Set Method, with Portland Cement Mortar					

2024 Code Section	TITLE OR SUBJECT	Reviewer Comments	Cost Yes/No	Amendment Needed Yes/No	TAG Comments/ Recommendation
R702.4.1 A108.1B—2017	Installation of Ceramic Tile on a Cured Portland Cement Mortar Setting Bed with Dry-Set or Latex Portland Cement Mortar				
R702.4.1 A108.4—19	Installation of Ceramic Tile with Organic Adhesives or Water-cleanable Tile-setting Epoxy Adhesive				
R702.4.1 A108.5—21	Setting of Ceramic Tile with Dry-Set Cement Mortar, Modified Dry-Set Cement Mortar, EGP (Exterior Glue Plywood) Modified Dry-Set Cement Mortar, or Improved Modified Dry-Set Cement Mortar				
R702.4.1 A108.6—99 (R2019)	Installation of Ceramic Tile with Chemical Resistant, Water Cleanable Tile-Setting and -Grouting Epoxy				
R702.4.1 A108.11—18	Interior Installation of Cementitious Backer Units				
R702.4.1 A118.1—19	American National Standard Specifications for Dry-Set Portland Cement Mortar				
R702.4.1 A118.3—21	American National Standard Specifications for Chemical-Resistant, Water-Cleanable Tile-Setting and -Grouting Epoxy and Water Cleanable Tile-Setting Epoxy Adhesive				
R702.4.1 A118.4—19	American National Standard Specifications for Modified Dry-Set Cement Mortar				
R606.2.11 A118.10—14 (2019)	Standard Specification for Load-Bearing, Bonded, Waterproof Membranes for Thin-Set Ceramic Tile and Dimension Stone Installation				
P2709.2P2709.2.4 A136.1—20	American National Standard Specifications for Organic Adhesives for Installation of Ceramic Tile				

2024 Code Section	TITLE OR SUBJECT	Reviewer Comments	Cost Yes/No	Amendment Needed Yes/No	TAG Comments/ Recommendation
	<p>R702.4.1 A137.1—22 American National Standard Specifications for Ceramic Tile</p> <p>R702.4.1 ANSI 40.11—1996 (R2017)/CGA 2.91—M96 (R2017) Gas-Fired, Heat-Activated Air-Conditioning and Heat Pump Appliances</p> <p>G2449.1 ANSI 117—2020 Standard Specification for Structural Glued Laminated Timber of Softwood Species</p> <p>R502.1.3R602.1.3R802.1.3 ANSI Z21.5.1—2017/CSA 7.1—17 Gas Clothes Dryers—Volume I—Type 1 Clothes Dryers</p> <p>G2438.1 ANSI Z21.8—1994 (R2017) Installation of Domestic Gas Conversion Burners</p> <p>G2443.1 ANSI Z21.13—2017/CSA 4.9—17 Gas-Fired Low-Pressure Steam and Hot Water Boilers</p> <p>G2452.1 ANSI Z21.20—2005 (R2016) Automatic Gas Ignition Systems and Components</p> <p>N1103.13N1104.1.5 ANSI Z21.22—2015 (R2020)/CSA 4.4—15 (R2020) Relief Valves for Hot Water Supply Systems</p> <p>P2804.2P2804.7 ANSI Z21.24—2015 (R2020)/CSA 6.10—15 (R2020) Connectors for Gas Appliances</p> <p>G2422.1G2422.2 ANSI Z21.40.1—1996 (R2017)/CGA 2.91—M96 (R2017) Gas-Fired Heat Activated Air Conditioning and Heat Pump Appliances</p> <p>G2449.2 A108.1A—17</p>				

2024 Code Section	TITLE OR SUBJECT	Reviewer Comments	Cost Yes/No	Amendment Needed Yes/No	TAG Comments/ Recommendation
	Installation of Ceramic Tile in the Wet-Set Method, with Portland Cement Mortar R702.4.1 A108.1B—2017				
	Installation of Ceramic Tile on a Cured Portland Cement Mortar Setting Bed with Dry-Set or Latex Portland Cement Mortar R702.4.1 A108.4—19				
	Installation of Ceramic Tile with Organic Adhesives or Water-cleanable Tile-setting Epoxy Adhesive R702.4.1 A108.5—21				
	Setting of Ceramic Tile with Dry-Set Cement Mortar, Modified Dry-Set Cement Mortar, EGP (Exterior Glue Plywood) Modified Dry-Set Cement Mortar, or Improved Modified Dry-Set Cement Mortar R702.4.1 A108.6—99 (R2019)				
	Installation of Ceramic Tile with Chemical Resistant, Water Cleanable Tile-Setting and -Grouting Epoxy R702.4.1 A108.11—18				
	Interior Installation of Cementitious Backer Units R702.4.1 A118.1—19				
	American National Standard Specifications for Dry-Set Portland Cement Mortar R702.4.1 A118.3—21				
	American National Standard Specifications for Chemical-Resistant, Water-Cleanable Tile-Setting and -Grouting Epoxy and Water Cleanable Tile-Setting Epoxy Adhesive R702.4.1 A118.4—19				
	American National Standard Specifications for Modified Dry-Set Cement Mortar R606.2.11 A118.10—14 (2019)				
	Standard Specification for Load-Bearing, Bonded, Waterproof Membranes for Thin-Set Ceramic Tile and Dimension Stone Installation P2709.2P2709.2.4 A136.1—20				

2024 Code Section	TITLE OR SUBJECT	Reviewer Comments	Cost Yes/No	Amendment Needed Yes/No	TAG Comments/ Recommendation
	<p>American National Standard Specifications for Organic Adhesives for Installation of Ceramic Tile R702.4.1 A137.1—22 American National Standard Specifications for Ceramic Tile R702.4.1 ANSI 40.11—1996 (R2017)/CGA 2.91—M96 (R2017) Gas-Fired, Heat-Activated Air-Conditioning and Heat Pump Appliances G2449.1 ANSI 117—2020 Standard Specification for Structural Glued Laminated Timber of Softwood Species R502.1.3R602.1.3R802.1.3 ANSI Z21.5.1—2017/CSA 7.1—17 Gas Clothes Dryers—Volume I—Type 1 Clothes Dryers G2438.1 ANSI Z21.8—1994 (R2017) Installation of Domestic Gas Conversion Burners G2443.1 ANSI Z21.13—2017/CSA 4.9—17 Gas-Fired Low-Pressure Steam and Hot Water Boilers G2452.1 ANSI Z21.20—2005 (R2016) Automatic Gas Ignition Systems and Components N1103.13N1104.1.5 ANSI Z21.22—2015 (R2020)/CSA 4.4—15 (R2020) Relief Valves for Hot Water Supply Systems P2804.2P2804.7 ANSI Z21.24—2015 (R2020)/CSA 6.10—15 (R2020) Connectors for Gas Appliances G2422.1G2422.2 ANSI Z21.40.1—1996 (R2017)/CGA 2.91—M96 (R2017) Gas-Fired Heat Activated Air Conditioning and Heat Pump Appliances G2449.2</p>				

2024 Code Section	TITLE OR SUBJECT	Reviewer Comments	Cost Yes/No	Amendment Needed Yes/No	TAG Comments/ Recommendation
	<p>ANSI Z21.41—(R2019)/CSA 6.9—(R2019) Quick Disconnect Devices for Use with Gas Fuel Appliances G2422.1</p> <p>ANSI Z21.50—2019/CSA 2.22—19 Vented Decorative Gas Fireplaces G2434.1</p> <p>ANSI Z21.60—2017/CSA 2.26—17 Decorative Gas Appliances for Installation in Solid-Fuel-Burning Fireplaces G2432.1</p> <p>ANSI Z21.69—2015 (2020)/CSA 6.16—15 (R2020) Connectors for Moveable Gas Appliances G2422.1.5</p> <p>ANSI Z21.75—2016/CSA 6.27—16 (R2020) Connectors for Outdoor Gas Appliances and Manufactured Homes G2422.1</p> <p>ANSI Z21.84—2017 Standard for Manually Lighted, Natural Gas, Decorative Gas Appliances for Installation in Solid-Fuel-Burning Appliances G2432.1G2432.2</p> <p>ANSI Z21.86—2016/CSA 2.32—16 Vented Gas-Fired Space Heating Appliances G2436.1G2437.1G2446.1</p> <p>ANSI Z21.93—2017/CSA 6.30—17 Excess Flow Valves for Natural Gas and Propane Gas with Pressures Up to 5 psig G2421.4</p> <p>ANSI Z21.97—2017/CSA 2.41—17 Outdoor Decorative Gas Appliances G2453.1</p> <p>ANSI Z83.8—2016/CSA 2.6—16 Gas Unit Heater, Gas Packaged Heaters, Gas Utility Heaters and Gas-Fired Duct Furnaces G2444.1</p> <p>ANSI Z83.19—2017/CSA 2.35—17 Gas-Fired High-Intensity Infrared Heaters</p>				

2024 Code Section	TITLE OR SUBJECT	Reviewer Comments	Cost Yes/No	Amendment Needed Yes/No	TAG Comments/ Recommendation
	<p>G2451.1 ANSI Z83.20—2016/CSA 2.34—16 Gas-Fired Tubular and Low-Intensity Infrared Heaters</p> <p>G2451.1 ANSI/ASHRAE 140—2017 (R2020) Standard Method of Test for the Evaluation of Building Energy Analysis Computer Programs</p> <p>N1105.5.2N1106.7.1 ANSI/CTA 2045-B—February 2021 Modular Communications Interface for Energy Management</p> <p>N1108.2.8.1 CSA/ANSI FC 1—21/CSA C22.2 NO. 62282-3-100—21 Fuel Cell Technologies—Part 3-100: Stationary Fuel Cell Power Systems—Safety</p> <p>M1903.1 CSA/ANSI LC 1—19/CSA 6.26—19 Fuel Gas Piping Systems Using Corrugated Stainless Steel Tubing (CSST)</p> <p>G2411.3G2414.4.4G2415.5 CSA/ANSI LC 4—23/CSA 6.32—23 Press-Connect Metallic Fittings and Valves for Use in Fuel Gas Distribution Systems</p> <p>G2414.9.1G2414.9.2G2414.9.3G2415.5 CSA/ANSI Z21.10.1—19/CSA 4.1—19 Gas Water Heaters, Volume I, Storage Water Heaters with Input Ratings of 75,000 Btu per hour or Less</p> <p>G2448.1 A108.1A—17 Installation of Ceramic Tile in the Wet-Set Method, with Portland Cement Mortar</p> <p>R702.4.1 A108.1B—2017 Installation of Ceramic Tile on a Cured Portland Cement Mortar Setting Bed with Dry-Set or Latex Portland Cement Mortar</p> <p>R702.4.1 A108.4—19 Installation of Ceramic Tile with Organic Adhesives or Water-cleanable Tile-setting Epoxy Adhesive</p> <p>R702.4.1 A108.5—21</p>				

2024 Code Section	TITLE OR SUBJECT	Reviewer Comments	Cost Yes/No	Amendment Needed Yes/No	TAG Comments/ Recommendation
	<p data-bbox="203 284 1848 349">Setting of Ceramic Tile with Dry-Set Cement Mortar, Modified Dry-Set Cement Mortar, EGP (Exterior Glue Plywood) Modified Dry-Set Cement Mortar, or Improved Modified Dry-Set Cement Mortar</p> <p data-bbox="203 357 317 386">R702.4.1</p> <p data-bbox="203 394 453 423">A108.6—99 (R2019)</p> <p data-bbox="203 431 1482 461">Installation of Ceramic Tile with Chemical Resistant, Water Cleanable Tile-Setting and -Grouting Epoxy</p> <p data-bbox="203 469 317 498">R702.4.1</p> <p data-bbox="203 506 365 535">A108.11—18</p> <p data-bbox="203 544 816 573">Interior Installation of Cementitious Backer Units</p> <p data-bbox="203 581 317 610">R702.4.1</p> <p data-bbox="203 618 348 647">A118.1—19</p> <p data-bbox="203 656 1197 685">American National Standard Specifications for Dry-Set Portland Cement Mortar</p> <p data-bbox="203 693 317 722">R702.4.1</p> <p data-bbox="203 730 348 760">A118.3—21</p> <p data-bbox="203 768 1812 833">American National Standard Specifications for Chemical-Resistant, Water-Cleanable Tile-Setting and -Grouting Epoxy and Water Cleanable Tile-Setting Epoxy Adhesive</p> <p data-bbox="203 841 317 870">R702.4.1</p> <p data-bbox="203 878 348 907">A118.4—19</p> <p data-bbox="203 915 1201 945">American National Standard Specifications for Modified Dry-Set Cement Mortar</p> <p data-bbox="203 953 331 982">R606.2.11</p> <p data-bbox="203 990 449 1019">A118.10—14 (2019)</p> <p data-bbox="203 1027 1869 1057">Standard Specification for Load-Bearing, Bonded, Waterproof Membranes for Thin-Set Ceramic Tile and Dimension Stone Installation</p> <p data-bbox="203 1065 436 1094">P2709.2P2709.2.4</p> <p data-bbox="203 1102 348 1131">A136.1—20</p> <p data-bbox="203 1140 1407 1169">American National Standard Specifications for Organic Adhesives for Installation of Ceramic Tile</p> <p data-bbox="203 1177 317 1206">R702.4.1</p> <p data-bbox="203 1214 348 1243">A137.1—22</p> <p data-bbox="203 1252 951 1281">American National Standard Specifications for Ceramic Tile</p> <p data-bbox="203 1289 317 1318">R702.4.1</p> <p data-bbox="203 1326 846 1356">ANSI 40.11—1996 (R2017)/CGA 2.91—M96 (R2017)</p> <p data-bbox="203 1364 1089 1393">Gas-Fired, Heat-Activated Air-Conditioning and Heat Pump Appliances</p> <p data-bbox="203 1401 310 1430">G2449.1</p> <p data-bbox="203 1438 411 1468">ANSI 117—2020</p>				

2024 Code Section	TITLE OR SUBJECT	Reviewer Comments	Cost Yes/No	Amendment Needed Yes/No	TAG Comments/ Recommendation
	<p>Standard Specification for Structural Glued Laminated Timber of Softwood Species R502.1.3R602.1.3R802.1.3 ANSI Z21.5.1—2017/CSA 7.1—17 Gas Clothes Dryers—Volume I—Type 1 Clothes Dryers G2438.1 ANSI Z21.8—1994 (R2017) Installation of Domestic Gas Conversion Burners G2443.1 ANSI Z21.13—2017/CSA 4.9—17 Gas-Fired Low-Pressure Steam and Hot Water Boilers G2452.1 ANSI Z21.20—2005 (R2016) Automatic Gas Ignition Systems and Components N1103.13N1104.1.5 ANSI Z21.22—2015 (R2020)/CSA 4.4—15 (R2020) Relief Valves for Hot Water Supply Systems P2804.2P2804.7 ANSI Z21.24—2015 (R2020)/CSA 6.10—15 (R2020) Connectors for Gas Appliances G2422.1G2422.2 ANSI Z21.40.1—1996 (R2017)/CGA 2.91—M96 (R2017) Gas-Fired Heat Activated Air Conditioning and Heat Pump Appliances G2449.2 ANSI Z21.41—(R2019)/CSA 6.9—(R2019) Quick Disconnect Devices for Use with Gas Fuel Appliances G2422.1 ANSI Z21.50—2019/CSA 2.22—19 Vented Decorative Gas Fireplaces G2434.1 ANSI Z21.60—2017/CSA 2.26—17 Decorative Gas Appliances for Installation in Solid-Fuel-Burning Fireplaces G2432.1</p>				

2024 Code Section	TITLE OR SUBJECT	Reviewer Comments	Cost Yes/No	Amendment Needed Yes/No	TAG Comments/ Recommendation
	<p>ANSI Z21.69—2015 (2020)/CSA 6.16—15 (R2020) Connectors for Moveable Gas Appliances G2422.1.5</p> <p>ANSI Z21.75—2016/CSA 6.27—16 (R2020) Connectors for Outdoor Gas Appliances and Manufactured Homes G2422.1</p> <p>ANSI Z21.84—2017 Standard for Manually Lighted, Natural Gas, Decorative Gas Appliances for Installation in Solid-Fuel-Burning Appliances G2432.1G2432.2</p> <p>ANSI Z21.86—2016/CSA 2.32—16 Vented Gas-Fired Space Heating Appliances G2436.1G2437.1G2446.1</p> <p>ANSI Z21.93—2017/CSA 6.30—17 Excess Flow Valves for Natural Gas and Propane Gas with Pressures Up to 5 psig G2421.4</p> <p>ANSI Z21.97—2017/CSA 2.41—17 Outdoor Decorative Gas Appliances G2453.1</p> <p>ANSI Z83.8—2016/CSA 2.6—16 Gas Unit Heater, Gas Packaged Heaters, Gas Utility Heaters and Gas-Fired Duct Furnaces G2444.1</p> <p>ANSI Z83.19—2017/CSA 2.35—17 Gas-Fired High-Intensity Infrared Heaters G2451.1</p> <p>ANSI Z83.20—2016/CSA 2.34—16 Gas-Fired Tubular and Low-Intensity Infrared Heaters G2451.1</p> <p>ANSI/ASHRAE 140—2017 (R2020) Standard Method of Test for the Evaluation of Building Energy Analysis Computer Programs N1105.5.2N1106.7.1</p> <p>ANSI/CTA 2045-B—February 2021 Modular Communications Interface for Energy Management</p>				

2024 Code Section	TITLE OR SUBJECT	Reviewer Comments	Cost Yes/No	Amendment Needed Yes/No	TAG Comments/ Recommendation
N1108.2.8.1	CSA/ANSI FC 1—21/CSA C22.2 NO. 62282-3-100—21 Fuel Cell Technologies—Part 3-100: Stationary Fuel Cell Power Systems—Safety				
M1903.1	CSA/ANSI LC 1—19/CSA 6.26—19 Fuel Gas Piping Systems Using Corrugated Stainless Steel Tubing (CSST)				
G2411.3G2414.4.4G2415.5	CSA/ANSI LC 4—23/CSA 6.32—23 Press-Connect Metallic Fittings and Valves for Use in Fuel Gas Distribution Systems				
G2414.9.1G2414.9.2G2414.9.3G2415.5	CSA/ANSI Z21.10.1—19/CSA 4.1—19 Gas Water Heaters, Volume I, Storage Water Heaters with Input Ratings of 75,000 Btu per hour or Less				
G2448.1	CSA/ANSI Z21.10.3—19/CSA 4.3—19 Gas Water Heaters—Volume III—Storage Water Heaters with Input Ratings above 75,000 Btu per Hour, Circulating and Instantaneous				
G2448.1	CSA/ANSI Z21.11.2—19 Gas-Fired Room Heaters, Volume II, Unvented Room Heaters				
G2445.1	CSA/ANSI Z21.15—22/CSA 9.1—22 Manually Operated Gas Valves for Appliances, Appliance Connector Valves and Hose End Valves				
Table G2420.1.1	CSA/ANSI Z21.42—13 (R2018) Gas-Fired Illuminating Appliances				
G2450.1	CSA/ANSI Z21.54—19/CSA 8.4—19 Gas Hose Connectors for Portable Outdoor Gas-Fired Appliances				
G2422.1	CSA/ANSI Z21.56—19/CSA 4.7—19 Gas-Fired Pool Heaters				
G2441.1	A108.1A—17				

2024 Code Section	TITLE OR SUBJECT	Reviewer Comments	Cost Yes/No	Amendment Needed Yes/No	TAG Comments/ Recommendation
	<p>Installation of Ceramic Tile in the Wet-Set Method, with Portland Cement Mortar R702.4.1 A108.1B—2017 Installation of Ceramic Tile on a Cured Portland Cement Mortar Setting Bed with Dry-Set or Latex Portland Cement Mortar R702.4.1 A108.4—19 Installation of Ceramic Tile with Organic Adhesives or Water-cleanable Tile-setting Epoxy Adhesive R702.4.1 A108.5—21 Setting of Ceramic Tile with Dry-Set Cement Mortar, Modified Dry-Set Cement Mortar, EGP (Exterior Glue Plywood) Modified Dry-Set Cement Mortar, or Improved Modified Dry-Set Cement Mortar R702.4.1 A108.6—99 (R2019e) Installation of Ceramic Tile with Chemical Resistant, Water Cleanable Tile-Setting and -Grouting Epoxy R702.4.1 A108.11—18 Interior Installation of Cementitious Backer Units R702.4.1 A118.1—19 American National Standard Specifications for Dry-Set Portland Cement Mortar R702.4.1 A118.3—21 American National Standard Specifications for Chemical-Resistant, Water-Cleanable Tile-Setting and -Grouting Epoxy and Water Cleanable Tile-Setting Epoxy Adhesive R702.4.1 A118.4—19 American National Standard Specifications for Modified Dry-Set Cement Mortar R606.2.11 A118.10—14 (2019) Standard Specification for Load-Bearing, Bonded, Waterproof Membranes for Thin-Set Ceramic Tile and Dimension Stone Installation P2709.2P2709.2.4 A136.1—20</p>				

2024 Code Section	TITLE OR SUBJECT	Reviewer Comments	Cost Yes/No	Amendment Needed Yes/No	TAG Comments/ Recommendation
	<p>American National Standard Specifications for Organic Adhesives for Installation of Ceramic Tile R702.4.1 A137.1—22 American National Standard Specifications for Ceramic Tile R702.4.1 ANSI 40.11—1996 (R2017)/CGA 2.91—M96 (R2017) Gas-Fired, Heat-Activated Air-Conditioning and Heat Pump Appliances G2449.1 ANSI 117—2020 Standard Specification for Structural Glued Laminated Timber of Softwood Species R502.1.3R602.1.3R802.1.3 ANSI Z21.5.1—2017/CSA 7.1—17 Gas Clothes Dryers—Volume I—Type 1 Clothes Dryers G2438.1 ANSI Z21.8—1994 (R2017) Installation of Domestic Gas Conversion Burners G2443.1 ANSI Z21.13—2017/CSA 4.9—17 Gas-Fired Low-Pressure Steam and Hot Water Boilers G2452.1 ANSI Z21.20—2005 (R2016) Automatic Gas Ignition Systems and Components N1103.13N1104.1.5 ANSI Z21.22—2015 (R2020)/CSA 4.4—15 (R2020) Relief Valves for Hot Water Supply Systems P2804.2P2804.7 ANSI Z21.24—2015 (R2020)/CSA 6.10—15 (R2020) Connectors for Gas Appliances G2422.1G2422.2 ANSI Z21.40.1—1996 (R2017)/CGA 2.91—M96 (R2017) Gas-Fired Heat Activated Air Conditioning and Heat Pump Appliances G2449.2</p>				

2024 Code Section	TITLE OR SUBJECT	Reviewer Comments	Cost Yes/No	Amendment Needed Yes/No	TAG Comments/ Recommendation
	<p>ANSI Z21.41—(R2019)/CSA 6.9—(R2019) Quick Disconnect Devices for Use with Gas Fuel Appliances G2422.1</p> <p>ANSI Z21.50—2019/CSA 2.22—19 Vented Decorative Gas Fireplaces G2434.1</p> <p>ANSI Z21.60—2017/CSA 2.26—17 Decorative Gas Appliances for Installation in Solid-Fuel-Burning Fireplaces G2432.1</p> <p>ANSI Z21.69—2015 (2020)/CSA 6.16—15 (R2020) Connectors for Moveable Gas Appliances G2422.1.5</p> <p>ANSI Z21.75—2016/CSA 6.27—16 (R2020) Connectors for Outdoor Gas Appliances and Manufactured Homes G2422.1</p> <p>ANSI Z21.84—2017 Standard for Manually Lighted, Natural Gas, Decorative Gas Appliances for Installation in Solid-Fuel-Burning Appliances G2432.1G2432.2</p> <p>ANSI Z21.86—2016/CSA 2.32—16 Vented Gas-Fired Space Heating Appliances G2436.1G2437.1G2446.1</p> <p>ANSI Z21.93—2017/CSA 6.30—17 Excess Flow Valves for Natural Gas and Propane Gas with Pressures Up to 5 psig G2421.4</p> <p>ANSI Z21.97—2017/CSA 2.41—17 Outdoor Decorative Gas Appliances G2453.1</p> <p>ANSI Z83.8—2016/CSA 2.6—16 Gas Unit Heater, Gas Packaged Heaters, Gas Utility Heaters and Gas-Fired Duct Furnaces G2444.1</p> <p>ANSI Z83.19—2017/CSA 2.35—17 Gas-Fired High-Intensity Infrared Heaters</p>				

2024 Code Section	TITLE OR SUBJECT	Reviewer Comments	Cost Yes/No	Amendment Needed Yes/No	TAG Comments/ Recommendation
	<p>G2451.1 ANSI Z83.20—2016/CSA 2.34—16 Gas-Fired Tubular and Low-Intensity Infrared Heaters</p> <p>G2451.1 ANSI/ASHRAE 140—2017 (R2020) Standard Method of Test for the Evaluation of Building Energy Analysis Computer Programs</p> <p>N1105.5.2N1106.7.1 ANSI/CTA 2045-B—February 2021 Modular Communications Interface for Energy Management</p> <p>N1108.2.8.1 CSA/ANSI FC 1—21/CSA C22.2 NO. 62282-3-100—21 Fuel Cell Technologies—Part 3-100: Stationary Fuel Cell Power Systems—Safety</p> <p>M1903.1 CSA/ANSI LC 1—19/CSA 6.26—19 Fuel Gas Piping Systems Using Corrugated Stainless Steel Tubing (CSST)</p> <p>G2411.3G2414.4.4G2415.5 CSA/ANSI LC 4—23/CSA 6.32—23 Press-Connect Metallic Fittings and Valves for Use in Fuel Gas Distribution Systems</p> <p>G2414.9.1G2414.9.2G2414.9.3G2415.5 CSA/ANSI Z21.10.1—19/CSA 4.1—19 Gas Water Heaters, Volume I, Storage Water Heaters with Input Ratings of 75,000 Btu per hour or Less</p> <p>G2448.1 CSA/ANSI Z21.10.3—19/CSA 4.3—19 Gas Water Heaters—Volume III—Storage Water Heaters with Input Ratings above 75,000 Btu per Hour, Circulating and Instantaneous</p> <p>G2448.1 CSA/ANSI Z21.11.2—19 Gas-Fired Room Heaters, Volume II, Unvented Room Heaters</p> <p>G2445.1 CSA/ANSI Z21.15—22/CSA 9.1—22 Manually Operated Gas Valves for Appliances, Appliance Connector Valves and Hose End Valves</p> <p>Table G2420.1.1 CSA/ANSI Z21.42—13 (R2018)</p>				

2024 Code Section	TITLE OR SUBJECT	Reviewer Comments	Cost Yes/No	Amendment Needed Yes/No	TAG Comments/ Recommendation
	Gas-Fired Illuminating Appliances G2450.1 CSA/ANSI Z21.54—19/CSA 8.4—19				
	Gas Hose Connectors for Portable Outdoor Gas-Fired Appliances G2422.1 CSA/ANSI Z21.56—19/CSA 4.7—19				
	Gas-Fired Pool Heaters G2441.1 CSA/ANSI Z21.58—22/CSA 1.6—22				
	Outdoor Cooking Gas Appliances G2447.1 CSA/ANSI Z21.80—19/CSA 6.22—19				
	Line Pressure Regulators G2421.1 CSA/ANSI Z21.88—19/CSA 2.33—19				
	Vented Gas Fireplace Heaters N1103.13.1G2435.1 CSA/ANSI Z21.90—19/CSA 6.24—19				
	Gas Convenience Outlets and Optional Enclosures G2422.1 CSA/ANSI Z21.91—20				
	Ventless Firebox Enclosures for Gas-Fired Unvented Decorative Room Heaters G2445.7.1 CSA/Z21.40.2/CGA 2.92—96 (R2017)				
	Gas-Fired Work Activated Air-Conditioning and Heat Pump Appliances (Internal Combustion) G2449.1 CSA/Z21.47—21/CSA 2.3—21				
	Gas-Fired Central Furnaces G2442.1 Z21.1/CSA 1.1—2018				
	Household Cooking Gas Appliances M1503.2G2447.1				

2024 Code Section	TITLE OR SUBJECT	Reviewer Comments	Cost Yes/No	Amendment Needed Yes/No	TAG Comments/ Recommendation
Z21.8—94 (R2017) Installation of Domestic Gas Conversion Burners G2443.1 Z21.50—19/CSA 2.22—2019 Vented Decorative Gas Appliances N1103.13.1 Z83.6—90 (R1998) Gas-Fired Infrared Heaters G2451.1 Z83.20—2016 Gas-Fired Tubular Low-Intensity Infrared Heaters G2451.1 Z97.1—2015 (R2020) Safety Glazing Materials Used in Buildings—Safety Performance Specifications and Methods of Test R324.1.1 R324.3.1					
APA	The Engineered Wood Association			NO	
ANSI/APA A190.1—2022 Product Standard for Structural Glued-laminated Timber R502.1.3 R602.1.3 R802.1.2 ANSI/APA PRG 320—2019 Standard for Performance-rated Cross Laminated Timber R502.1.6 R602.1.6 R802.1.5 ANSI/APA PRP 210—2019 Standard for Performance-rated Engineered Wood Siding R604.1 Table R703.3(1) R703.3.4 ANSI/APA PRR 410—2021 Standard for Performance-rated Engineered Wood Rim Boards R502.1.7 R602.1.7 R802.1.6 ANSI/APA PRS 610.1—2023 Standard for Performance-Rated Structural Insulated Panels in Wall Applications					

2024 Code Section	TITLE OR SUBJECT	Reviewer Comments	Cost Yes/No	Amendment Needed Yes/No	TAG Comments/ Recommendation
R602.1.11 R610.3 R610.4 APA E30—19 Engineered Wood Construction Guide Table R503.2.1.1(1) R503.2.2 R803.2.2 R803.2.3					
ASCE/SEI	American Society of Civil Engineers			NO	
7—2022 Minimum Design Loads and Associated Criteria for Buildings and Other Structures R301.2.1.1 R301.2.1.2 R301.2.1.5 R301.2.1.5.1 Table R608.6(1) Table R608.6(2) Table R608.6(3) Table R608.6(4) Table R608.7.1.1(1) Table R608.7.1.1(2) Table R608.7.1.1(3) R608.9.2 R608.9.3 R609.2 R609.6.2 24—14 Flood Resistant Design and Construction R301.2.4 R301.2.4.1 R306.1 R306.1 R306.1.1 R306.1.6 R306.1.9 R306.2.2 R306.3.3 32—01 Design and Construction of Frost-protected Shallow Foundations R403.1.4.1					
ASHRAE	ASHREAE			YES	State Amendment adds 62.2-2019. A 2022 version is available.
ANSI/ASHRAE/IES 90.1—2022 Energy Standard for Sites and Buildings Except Low-Rise Residential Buildings N1102.1.5 ASHRAE 34—2022 Designation Classification of Refrigerants M1411.1 ASHRAE 193—2010(RA 2014) Method of Test for Determining the Airtightness of HVAC Equipment N1103.3.6.1 ASHRAE—2001					

2024 Code Section	TITLE OR SUBJECT	Reviewer Comments	Cost Yes/No	Amendment Needed Yes/No	TAG Comments/ Recommendation
	2001 ASHRAE Handbook of Fundamentals N1105.4.2Table N1105.4.2(1)N1102.1.5N1103.3.1 ASHRAE—2017 ASHRAE Handbook of Fundamentals N1102.1.5P3001.2P3101.4				
ASME	American Society of Mechanical Engineers			NO	
	A18.1—2023 Safety Standard for Platforms and Stairway Chair Lifts R323.2 A112.1.2—2012(R2017) Air Gaps in Plumbing Systems (For Plumbing Fixtures and Water Connected Receptors) P2717.1Table P2902.3P2902.3.1 A112.1.3—2000 (R2024) Air Gap Fittings for Fixtures, Appliances and Appurtenances Table P2701.1P2717.1Table P2902.3P2902.3.1 A112.3.1—2007 (R2017) Stainless Steel Drainage Systems for Sanitary, DWV, Storm and Vacuum Applications Above and Below Ground Table P3002.1(1)Table P3002.1(2)Table P3002.2Table P3002.3Table P3302.1 A112.3.4—2022/CSA B45.9—2022 Macerating Toilet Systems and Related Components Table P2701.1P3007.5 A112.4.1—2024 Water Heater Relief Valve Drain Tubes P2804.6.1 A112.4.3—2024 Plastic Fittings for Connecting Water Closets to the Sanitary Drainage System P3003.14 A112.4.4—2022 Plastic Push-Fit Drain, Waste, and Vent (DWV) Fittings				

2024 Code Section	TITLE OR SUBJECT	Reviewer Comments	Cost Yes/No	Amendment Needed Yes/No	TAG Comments/ Recommendation
	<p>Table P3002.3P3003.9.4 A112.4.14—2022/CSA B125.14—2022 Manually Operated Valves for Use in Plumbing Systems Table P2903.10.4 A112.6.2—2017 (R2022) Framing-affixed Supports (Carriers) for Off-the-Floor Water Closets with Concealed Tanks Table P2701.1P2702.4 A112.6.3—2022 Floor and Trench Drains Table P2701.1 A112.14.1—2003 (R2022) Backwater Valves P3008.3 A112.18.1—2023/CSA B125.1—2023 Plumbing Supply Fittings Table P2701.1P2708.5P2722.1P2722.3P2902.2Table P2903.10.4 A112.18.2—2023/CSA B125.2—2023 Plumbing Waste Fittings Table P2701.1P2702.2 A112.18.3—2002 (R2022) Performance Requirements for Backflow Protection Devices and Systems in Plumbing Fixture Fittings P2708.5P2722.3 A112.18.6—2021/CSA B125.6—21 Flexible Water Connectors P2906.7 A112.19.1—2022/CSA B45.2—2022 Enameled Cast-iron and Enameled Steel Plumbing Fixtures Table P2701.1P2711.1 A112.19.2—2021/CSA B45.1—2021 Ceramic Plumbing Fixtures Table P2701.1P2705.1P2711.1P2712.1P2712.2P2712.9 A112.19.3—2021/CSA B45.4—2021</p>				

2024 Code Section	TITLE OR SUBJECT	Reviewer Comments	Cost Yes/No	Amendment Needed Yes/No	TAG Comments/ Recommendation
	<p>Stainless Steel Plumbing Fixtures Table P2701.1P2705.1P2711.1P2712.1 A112.19.5—2022/CSA B45.15—2022 Flush Valves and Spuds for Water-closets, Urinals and Tanks Table P2701.1 A112.19.7—2023/CSA B45.10—2023 Hydromassage Bathtub Systems Table P2701.1 A112.19.12—2024 Wall-mounted and Pedestal-mounted, Adjustable, Elevating, Tilting, and Pivoting Lavatory and Sink, and Shampoo Bowl Carrier Systems and Drain Waste Systems Table P2701.1P2711.4P2714.2 A112.19.14—2013 (R2023) Six-Liter Water Closets Equipped with Dual Flushing Device P2712.1 A112.19.15—2012 (R2022) Bathtub/Whirlpool Bathtubs with Pressure-sealed Doors Table P2701.1P2713.2 A112.36.2M—1991 (R2022) Cleanouts P3005.2.10.2 ASME A17.1—2022/CSA B44—2022 Safety Code for Elevators and Escalators R323.1 ASME A112.4.2—2021/CSA B45.16—2021 Personal Hygiene Devices for Water Closets P2722.5 ASSE 1002—2020/ASME A112.1002—2020/CSA B125.12—20 Anti-Siphon Fill Valves for Water Closet Tanks Table P2701.1Table P2902.3P2902.4.1 ASSE 1016—2021/ASME A112.1016—2021/CSA B125.16—2021 Performance Requirements for Automatic Compensating Valves for Individual Showers and Tub/Shower Combinations</p>				

2024 Code Section	TITLE OR SUBJECT	Reviewer Comments	Cost Yes/No	Amendment Needed Yes/No	TAG Comments/ Recommendation
	<p>Table P2701.1P2708.4P2722.2 ASSE 1070—2020/ASME A112.1070—2020/CSA B125.1070—20 Performance Requirements for Water Temperature Limiting Devices P2713.3P2721.2 B1.20.1—2023 Pipe Threads, General Purpose (Inch) G2414.9P3003.3.3P3003.6.4P3003.7.1P3003.9.3 B16.3—2016 Malleable Iron Threaded Fittings, Classes 150 & 300 Table P2906.6 B16.4—2016 Gray Iron Threaded Fittings Classes 125 and 250 Table P2906.6Table P3002.3 B16.9—2023 Factory-made Wrought Steel Buttwelding Fittings Table P2906.6 B16.11—2021 Forged Fittings, Socket-welding and Threaded Table P2906.6 B16.12—2024 Cast Iron Threaded Drainage Fittings Table P3002.3 B16.15—2023 Cast Alloy Threaded Fittings: Classes 125 and 250 Table P2906.6Table P3002.3 B16.18—2023 Cast Copper Alloy Solder Joint Pressure Fittings Table P2906.6Table P3002.3 B16.22—2023 Wrought Copper and Copper Alloy Solder-Joint Pressure Fittings Table P2906.6Table P3002.3 B16.23—2016</p>				

2024 Code Section	TITLE OR SUBJECT	Reviewer Comments	Cost Yes/No	Amendment Needed Yes/No	TAG Comments/ Recommendation
	<p>Cast Copper Alloy Solder Joint Drainage Fittings DWV Table P3002.3 B16.26—2023</p> <p>Cast Copper Alloy Fittings for Flared Copper Tubes Table P2906.6Table P3002.3 B16.28—1994</p> <p>Wrought Steel Buttwelding Short Radius Elbows and Returns Table P2906.6 B16.29—2022</p> <p>Wrought Copper and Wrought Copper Alloy Solder Joint Drainage Fittings (DWV) Table P3002.3 B16.33—2022</p> <p>Manually Operated Metallic Gas Valves for Use in Gas Piping Systems up to 125 psig (Sizes 1/2 through 2) Table G2420.1.1 B16.34—2023</p> <p>Valves—Flanged, Threaded and Welding End Table P2903.10.4 B16.44—2022</p> <p>Manually Operated Metallic Gas Valves for Use in Aboveground Piping Systems up to 5 psi Table G2420.1.1 B16.51—2018</p> <p>Copper and Copper Alloy Press-Connect Pressure Fittings Table M2101.1M2103.3Table P2906.6 B36.10M—2023</p> <p>Welded and Seamless Wrought Steel Pipe G2414.4.2 BPVC—2023</p> <p>ASME Boiler and Pressure Vessel Code (Sections I, II, IV, V, VI and VIII) M2001.1.1G2452.1 CSD-1—2024</p> <p>Controls and Safety Devices for Automatically Fired Boilers M2001.1.1G2452.1</p>				

2024 Code Section	TITLE OR SUBJECT	Reviewer Comments	Cost Yes/No	Amendment Needed Yes/No	TAG Comments/ Recommendation
ASSE	ASSE International			NO	
<p>1001—2017 Performance Requirements for Atmospheric-type Vacuum Breakers Table P2902.3P2902.3.2</p> <p>1003—2020 Performance Requirements for Water-pressure-reducing Valves for Domestic Water Distribution Systems P2903.3.1</p> <p>1008—2020 Performance Requirements for Plumbing Aspects of Residential Food Waste Disposer Units Table P2701.1</p> <p>1010—2004 Performance Requirements for Water Hammer Arresters P2903.5</p> <p>1011—2017 Performance Requirements for Hose Connection Vacuum Breakers Table P2902.3P2902.3.2</p> <p>1012—2009 Performance Requirements for Backflow Preventers with an Intermediate Atmospheric Vent Table P2902.3P2902.3.3P2902.5.1P2902.5.5.3</p> <p>1013—2021 Performance Requirements for Reduced Pressure Principle Backflow Prevention Assemblies Table P2902.3P2902.3.5P2902.5.1P2902.5.5.3</p> <p>1015—2021 Performance Requirements for Double Check Backflow Prevention Assemblies Table P2902.3P2902.3.6</p> <p>1017—2009 Performance Requirements for Temperature Actuated Mixing Valves for Hot Water Distribution Systems P2724.1P2802.1P2803.2</p> <p>1018—2021 Performance Requirements for Trap Seal Primer Valves—Potable Water Supplied P3201.2.1.1P3201.2.1.2</p>					

2024 Code Section	TITLE OR SUBJECT	Reviewer Comments	Cost Yes/No	Amendment Needed Yes/No	TAG Comments/ Recommendation
1019—2011	Performance Requirements for Wall Hydrant with Backflow Protection and Freeze Resistance Table P2701.1 Table P2902.3 P2902.3.2				
1020—2020	Performance Requirements for Pressure Vacuum Breaker Assembly Table P2902.3 P2902.3.4				
1023—2020	Performance Requirements for Electrically Heated or Cooled Water Dispensers Table P2701.1				
1024—2021	Performance Requirements for Dual Check Backflow Preventers Table P2902.3 P2902.3.7				
1035—2020	Performance Requirements for Laboratory Faucet Backflow Preventers Table P2902.3 P2902.3.2				
1044—2015 (R2020)	Performance Requirements for Trap Seal Primer—Drainage Types and Electric Design Types P3201.2.1.3				
1047—2021	Performance Requirements for Reduced Pressure Detector Fire Protection Backflow Prevention Assemblies Table P2902.3 P2902.3.5				
1048—2021	Performance Requirements for Double Check Detector Fire Protection Backflow Prevention Assemblies Table P2902.3 P2902.3.6				
1050—2021	Performance Requirements for Stack Air Admittance Valves for Sanitary Drainage Systems P3114.1				
1051—2021	Performance Requirements for Individual and Branch Type Air Admittance Valves for Sanitary Drainage Systems P3114.1				
1052—2016	Performance Requirements for Hose Connection Backflow Preventers				

2024 Code Section	TITLE OR SUBJECT	Reviewer Comments	Cost Yes/No	Amendment Needed Yes/No	TAG Comments/ Recommendation
	Table P2701.1 Table P2902.3 P2902.3.2 1056—2013 (R2021) Performance Requirements for Spill Resistant Vacuum Breaker Assemblies Table P2902.3 P2902.3.4 1060—2017 (R2021) Performance Requirements for Outdoor Enclosures for Fluid-conveying Components P2902.6.1 1061—2020 Performance Requirements for Push-Fit Fittings Table P2906.6 P2906.21 1062—2021 Performance Requirements for Temperature-actuated, Flow Reduction (TAFR) Valves for Individual Supply Fittings Table P2701.1 P2724.2 1066—1997 Performance Requirements for Individual Pressure Balancing In-line Valves for Individual Fixture Fittings P2722.4 1072—2020 Performance Requirements for Trap Seal Protection for Floor Drains P3201.2.1.4 1081— 2014 (R2020) Performance Requirements for Backflow Preventers with Integral Pressure Reducing Boiler Feed Valve and Intermediate Atmospheric Vent Style for Domestic and Light Commercial Water Distribution Systems Table P2902.3 P2902.3.3 ASSE 1002—2020/ASME A112.1002—2020/CSA B125.12—20 Anti-Siphon Fill Valves for Water Closet Tanks Table P2701.1 Table P2902.3 P2902.4.1 ASSE 1016—2017/ASME 112.1016—2017/CSA B125.16—2017 Performance Requirements for Automatic Compensating Valves for Individual Showers and Tub/Shower Combinations Table P2701.1 P2708.4 P2722.2 ASSE 1037—2015/ASME A112.1037—2015/CSA B125.37—15 Performance Requirements for Pressurized Flushing Devices for Plumbing Fixtures Table P2701.1				

2024 Code Section	TITLE OR SUBJECT	Reviewer Comments	Cost Yes/No	Amendment Needed Yes/No	TAG Comments/ Recommendation
ASSE 1070—2020/ASME A112.1070—2020/ CSA B125.70—20	Performance Requirements for Water Temperature Limiting Devices P2713.3P2721.2P2724.1				
ASTM	ASTM International			NO	
	A36/A36M—19 Specification for Carbon Structural Steel R608.5.2.2 A53/A53M—2020 Specification for Pipe, Steel, Black and Hot-Dipped, Zinc-Coated Welded and Seamless R407.3Table M2101.1G2414.4.2Table P2906.4Table P2906.5Table P3002.1(1) A74—2021 Specification for Cast Iron Soil Pipe and Fittings Table P3002.1(1)Table P3002.1(2)Table P3002.2Table P3002.3P3005.2.6Table P3302.1 A106/A106M—2019a Specification for Seamless Carbon Steel Pipe for High-Temperature Service Table M2101.1G2414.4.2 A123/A123M—2017 Standard Specification for Zinc (Hot-Dip Galvanized) Coatings on Iron and Steel Products Table R507.2.3 A126—04(2019) Standard Specification for Gray Iron Castings for Valves, Flanges and Pipe Fittings Table P2903.10.4 A153/A153M—2016A Specification for Zinc Coating (Hot-Dip) on Iron and Steel Hardware R304.3Table R507.2.3Table R606.3.4.1R703.6.3R905.7.6R905.8.7 A167—99(2009) Specification for Stainless and Heat-resisting Chromium-Nickel Steel Plate, Sheet and Strip Table R606.3.4.1 A240/A240M—20a Standard Specification for Chromium and Chromium-Nickel Stainless Steel Plate, Sheet and Strip for Pressure Vessels and for General Applications				

2024 Code Section	TITLE OR SUBJECT	Reviewer Comments	Cost Yes/No	Amendment Needed Yes/No	TAG Comments/ Recommendation
	<p>Table R905.10.3(1) A254—A254M—12(2019) Specification for Copper-Brazed Steel Tubing</p> <p>Table M2101.1G2414.5.1 A268/A268M—20 Standard Specification for Seamless and Welded Ferritic and Martensitic Stainless Steel Tubing for General Service</p> <p>G2414.5.2 A269/A269M—15a(2019) Standard Specification for Seamless and Welded Austenitic Stainless Steel Tubing for General Service</p> <p>G2414.5.2 A307—21 Standard Specification for Carbon Steel Bolts, Studs, and Threaded Rod 60,000 PSI Tensile Strength</p> <p>Table R507.2.3R608.5.2.2 A312/A312M—21 Specification for Seamless, Welded and Heavily Cold Worked Austenitic Stainless Steel Pipes</p> <p>Table P2906.4Table P2906.5Table P2906.6P2906.13.2 A463/A463M—15(2020)e1 Standard Specification for Steel Sheet, Aluminum-Coated by the Hot-dip Process</p> <p>Table R905.10.3(2) A539—99 Specification for Electric-Resistance-Welded Coiled Steel Tubing for Gas and Fuel Oil Lines</p> <p>M2202.1 A563/A563M—21a Standard Specification for Carbon and Alloy Steel Nuts</p> <p>Table R507.2.3 A615/A615M—20 Standard Specification for Deformed and Plain Carbon-Steel Bars for Concrete Reinforcement</p> <p>R402.3.1R403.1.3.5.1R404.1.3.3.7.1R608.5.2.1 A641/A641M—19 Specification for Zinc-coated (Galvanized) Carbon Steel Wire</p> <p>Table R507.2.3Table R606.3.4.1R703.6.3R905.7.6R905.8.7 A653/A653M—20</p>				

2024 Code Section	TITLE OR SUBJECT	Reviewer Comments	Cost Yes/No	Amendment Needed Yes/No	TAG Comments/ Recommendation
	<p>Standard Specification for Steel Sheet, Zinc-Coated (Galvanized) or Zinc-Iron Alloy-Coated (Galvannealed) by the Hot-Dip Process R505.2.2Table R507.2.3R603.2.2Table R606.3.4.1R608.5.2.3R804.2.2R804.2.3Table R905.10.3(1)Table R905.10.3(2)M1601.1.1 A706/A706M—2016</p> <p>Standard Specification for Deformed and Plain Low Alloy Bars for Concrete Reinforcement R402.3.1R403.1.3.5.1R404.1.3.3.7.1R608.5.2.1 A755/A755M—18</p> <p>Specification for Steel Sheet, Metallic Coated by the Hot-Dip Process and Prepainted by the Coil-Coating Process for Exterior Exposed Building Products Table R905.10.3(2) A778/A778M—16(2021)</p> <p>Standard Specification for Welded Unannealed Austenitic Stainless Steel Tubular Products Table P2906.4Table P2906.5Table P2906.6 A792/A792M—21a</p> <p>Specification for Steel Sheet, 55% Aluminum-zinc Alloy-Coated by the Hot-Dip Process R505.2.2R603.2.2R608.5.2.3R804.2.2Table R905.10.3(2) A875/A875M—21</p> <p>Specification for Steel Sheet, Zinc-5%, Aluminum Alloy-Coated by the Hot-Dip Process R608.5.2.3Table R905.10.3(2) A888—21a</p> <p>Specification for Hubless Cast Iron Soil Pipe and Fittings for Sanitary and Storm Drain, Waste, and Vent Piping Application Table P3002.1(1)Table P3002.1(2)Table P3002.2Table P3002.3Table P3302.1 A924/A924M—20</p> <p>Standard Specification for General Requirements for Steel Sheet, Metallic-Coated by the Hot-Dip Process Table R905.10.3(1) A996M—2016</p> <p>Specifications for Rail-Steel and Axle-Steel Deformed Bars for Concrete Reinforcement R403.1.3.5.1Table R404.1.3.2(9)R404.1.3.3.7.1R608.5.2.1Table R608.5.4(2) A1003/A1003M—15</p> <p>Standard Specification for Steel Sheet, Carbon, Metallic and Nonmetallic-Coated for Cold-Formed Framing Members R505.2.1R505.2.2R603.2.1R603.2.2R804.2.1R804.2.2 B32—20</p> <p>Specification for Solder Metal</p>				

2024 Code Section	TITLE OR SUBJECT	Reviewer Comments	Cost Yes/No	Amendment Needed Yes/No	TAG Comments/ Recommendation
P3003.6.3	B42—20 Specification for Seamless Copper Pipe, Standard Sizes Table M2101.1Table P2906.4Table P2906.5Table P3002.1(1)				
	B43—20 Specification for Seamless Red Brass Pipe, Standard Sizes Table M2101.1Table P2906.4Table P2906.5Table P3002.1(1)				
	B75/B75M—20 Specification for Seamless Copper Tube Table M2101.1Table P2906.4Table P2906.5Table P3002.1(1)Table P3002.1(2)Table P3002.2				
	B88—20 Specification for Seamless Copper Water Tube Table M2101.1G2414.5.2Table P2906.4Table P2906.5Table P3002.1(1)Table P3002.1(2)Table P3002.2				
	B101—12(2019) Specification for Lead-Coated Copper Sheet and Strip for Building Construction Table R905.2.8.2Table R905.10.3(1)				
	B135/B135M—17 Specification for Seamless Brass Tube Table M2101.1				
	B209—21 Standard Specification for Aluminum and Aluminum-Alloy Sheet and Plate Table R905.10.3(1)				
	B251/B251M—2017 Specification for General Requirements for Wrought Seamless Copper and Copper-Alloy Tube Table M2101.1Table P2906.4Table P2906.5Table P3002.1(1)Table P3002.1(2)Table P3002.2				
	B280—20 Specification for Seamless Copper Tube for Air Conditioning and Refrigeration Field Service G2414.4.3				
	B302—17 Specification for Threadless Copper Pipe, Standard Sizes Table M2101.1Table P2906.4Table P2906.5Table P3002.1(1)				
	B306—20				

2024 Code Section	TITLE OR SUBJECT	Reviewer Comments	Cost Yes/No	Amendment Needed Yes/No	TAG Comments/ Recommendation
	<p>Specification for Copper Drainage Tube (DWV) Table M2101.1Table P3002.1(1)Table P3002.1(2) B370—12(2019)</p> <p>Specification for Copper Sheet and Strip for Building Construction Table R905.2.8.2Table R905.10.3(1)Table P2701.1 B447—12a(2021)</p> <p>Specification for Welded Copper Tube Table P2906.4Table P2906.5 B695—2021</p> <p>Standard Specification for Coatings of Zinc Mechanically Deposited on Iron and Steel Table R507.2.3 B813—2016</p> <p>Specification for Liquid and Paste Fluxes for Soldering of Copper and Copper Alloy Tube Table M2101.1M2103.3P2906.15P3003.6.3 B828—2016</p> <p>Practice for Making Capillary Joints by Soldering of Copper and Copper Alloy Tube and Fittings M2103.3P2906.15P3003.6.3 C4—2004(2018)</p> <p>Specification for Clay Drain Tile and Perforated Clay Drain Tile Table P3302.1 C5—2018</p> <p>Specification for Quicklime for Structural Purposes R702.2.1 C14—20</p> <p>Specification for Nonreinforced Concrete Sewer, Storm Drain and Culvert Pipe Table P3002.2 C22/C22M—00(2021)</p> <p>Specification for Gypsum R702.2.1R702.3.1 C27—1998(2018)</p> <p>Specification for Standard Classification of Fireclay and High-Alumina Refractory Brick R1001.5</p>				

2024 Code Section	TITLE OR SUBJECT	Reviewer Comments	Cost Yes/No	Amendment Needed Yes/No	TAG Comments/ Recommendation
	<p>C28/C28M—10(2020) Specification for Gypsum Plasters R702.2.1 C33/C33M—2018 Specification for Concrete Aggregates R403.4.1 C34—2017 Standard Specification for Structural Clay Loadbearing Wall Tile Table R301.2(1)R606.2.2 C35/C35M—01(2019) Standard Specification for Inorganic Aggregates for Use in Gypsum Plaster R702.2.1 C55—2017 Specification for Concrete Building Brick R202Table R301.2(1)R606.2.1 C56—2013(2017) Standard Specification for Structural Clay Nonloadbearing Tile R606.2.2 C59/C59M—00(2020) Specification for Gypsum Casting Plaster and Molding Plaster R702.2.1 C61/C61M—00(2020) Specification for Gypsum Keene’s Cement R702.2.1 C62—2017 Standard Specification for Building Brick (Solid Masonry Units Made from Clay or Shale) R202Table R301.2(1)R606.2.2 C73—2017 Specification for Calcium Silicate Brick (Sand-Lime Brick) R202Table R301.2(1)R606.2.1 C76—22 Specification for Reinforced Concrete Culvert, Storm Drain and Sewer Pipe</p>				

2024 Code Section	TITLE OR SUBJECT	Reviewer Comments	Cost Yes/No	Amendment Needed Yes/No	TAG Comments/ Recommendation
	<p>Table P3002.2 C90—21 Specification for Loadbearing Concrete Masonry Units</p> <p>Table R301.2(1)R606.2.1 C91/C91M—2018 Specification for Masonry Cement</p> <p>R702.2.2R703.7.2 C94/C94M—21b Standard Specification for Ready-Mixed Concrete</p> <p>R404.1.3.3.2R608.5.1.2 C126—19 Standard Specification for Ceramic Glazed Structural Clay Facing Tile, Facing Brick, and Solid Masonry Units</p> <p>R606.2.2 C129—2017 Specification for Nonload-Bearing Concrete Masonry Units</p> <p>Table R301.2(1) C143/C143M—20 Test Method for Slump of Hydraulic Cement Concrete</p> <p>R404.1.3.3.4R608.5.1.4 C145—85 Specification for Solid Load-Bearing Concrete Masonry Units</p> <p>R202Table R301.2(1) C150/C150M—21 Specification for Portland Cement</p> <p>R608.5.1.1R702.7.2 C199—1984(2016) Test Method for Pier Test for Refractory Mortars</p> <p>R1001.5R1001.8R1003.12 C207—2018 Specification for Hydrated Lime for Masonry Purposes</p> <p>Table R606.2.8 C208—22</p>				

2024 Code Section	TITLE OR SUBJECT	Reviewer Comments	Cost Yes/No	Amendment Needed Yes/No	TAG Comments/ Recommendation
	<p>Specification for Cellulosic Fiber Insulating Board R602.1.10Table R602.3(1)Table R906.2 C212—21</p> <p>Standard Specification for Structural Clay Facing Tile R606.2.2 C216—21</p> <p>Specification for Facing Brick (Solid Masonry Units Made from Clay or Shale) R202Table R301.2(1)R606.2.2 C270—19ae1</p> <p>Specification for Mortar for Unit Masonry R606.2.8Table R606.2.8R606.2.11 C315—2007(2021)</p> <p>Specification for Clay Flue Liners and Chimney Pots R1001.8R1003.11.1Table R1003.14(1)G2425.12 C406/C406M—2015</p> <p>Specification for Roofing Slate R905.6.4 C411—19</p> <p>Test Method for Hot-Surface Performance of High-Temperature Thermal Insulation M1601.3 C425—21</p> <p>Specification for Compression Joints for Vitrified Clay Pipe and Fittings Table P3002.2P3003.10P3003.13 C443—21</p> <p>Specification for Joints for Concrete Pipe and Manholes, Using Rubber Gaskets P3003.5P3003.13 C475/C475M—2017</p> <p>Specification for Joint Compound and Joint Tape for Finishing Gypsum Board R702.3.1 C476—20</p> <p>Specification for Grout for Masonry R606.2.12</p>				

2024 Code Section	TITLE OR SUBJECT	Reviewer Comments	Cost Yes/No	Amendment Needed Yes/No	TAG Comments/ Recommendation
	<p>C503/C503M—2015 Standard Specification for Marble Dimension Stone R606.2.4</p> <p>C514—04(2020) Standard Specification for Nails for the Application of Gypsum Board R702.3.1</p> <p>C552—22 Standard Specification for Cellular Glass Thermal Insulation Table R906.2</p> <p>C557—2003(2017) Specification for Adhesives for Fastening Gypsum Wallboard to Wood Framing R702.3.1.1</p> <p>C564—20a Specification for Rubber Gaskets for Cast Iron Soil Pipe and Fittings P3003.4.2P3003.4.3P3003.13</p> <p>C568M—2015 Standard Specification for Limestone Dimension Stone R606.2.4</p> <p>C578—19 Standard Specification for Rigid, Cellular Polystyrene Thermal Insulation R403.3Table R703.8.4(2)Table R703.15.1Table R703.15.2Table R703.16.1Table R703.16.2Table R906.2</p> <p>C587—2004(2018) Specification for Gypsum Veneer Plaster R702.2.1</p> <p>C595/C595M—21 Specification for Blended Hydraulic Cements R608.5.1.1R702.2.2R703.7.2</p> <p>C615/C615M—2018E1 Standard Specification for Granite Dimension Stone R606.2.4</p> <p>C616/C616M—2015 Standard Specification for Quartz-Based Dimension Stone</p>				

2024 Code Section	TITLE OR SUBJECT	Reviewer Comments	Cost Yes/No	Amendment Needed Yes/No	TAG Comments/ Recommendation
	<p>R606.2.4 C629/C629M—2015 Standard Specification for Slate Dimension Stone</p> <p>R606.2.4 C631—09(2020) Standard Specification for Bonding Compounds for Interior Gypsum Plastering</p> <p>R702.2.1 C645—2018 Specification for Nonstructural Steel Framing Members</p> <p>R702.3.3 C652—21 Specification for Hollow Brick (Hollow Masonry Units Made from Clay or Shale)</p> <p>R202Table R301.2(1)R606.2.2 C685/C685M—2017 Specification for Concrete Made by Volumetric Batching and Continuous Mixing</p> <p>R404.1.3.3.2R608.5.1.2 C700—2018 Specification for Vitrified Clay Pipe, Extra Strength, Standard Strength and Perforated</p> <p>Table P3002.2Table P3002.3Table P3302.1 C726—2017 Standard Specification for Mineral Wool Roof Insulation Board</p> <p>Table R906.2 C728—2017A Standard Specification for Perlite Thermal Insulation Board</p> <p>Table R906.2 C744—2021 Standard Specification for Prefaced Concrete and Calcium Silicate Masonry Units</p> <p>R606.2.1 C836/C836M—2018(2022) Specification for High Solids Content, Cold Liquid-Applied Elastomeric Waterproofing Membrane for Use with Separate Wearing Course</p> <p>R905.14.2 C841—2003(2018)</p>				

2024 Code Section	TITLE OR SUBJECT	Reviewer Comments	Cost Yes/No	Amendment Needed Yes/No	TAG Comments/ Recommendation
	Standard Specification for Installation of Interior Lathing and Furring R702.2.1 C842—05(2021)				
	Standard Specification for Application of Interior Gypsum Plaster R702.2.1 C843—2017				
	Specification for Application of Gypsum Veneer Plaster R702.2.1 C844—2015(2021)				
	Specification for Application of Gypsum Base to Receive Gypsum Veneer Plaster R702.2.1 C847—18				
	Specification for Metal Lath R702.2.1R702.2.2 C887—20				
	Specification for Packaged, Dry, Combined Materials for Surface Bonding Mortar R406.1R606.2.9 C897—15(2020)				
	Specification for Aggregate for Job-Mixed Portland Cement-Based Plasters R702.2.2 C920—2018				
	Standard Specification for Elastomeric Joint Sealants R406.4.1 C926—21				
	Specification for Application of Portland Cement-Based Plaster R702.2.2R702.2.2.1R703.7R703.7.2R703.7.2.1R703.7.4 C933—2018				
	Specification for Welded Wire Lath R702.2.1R702.2.2 C946—2018				
	Standard Practice for Construction of Dry-Stacked, Surface-Bonded Walls R606.2.9				

2024 Code Section	TITLE OR SUBJECT	Reviewer Comments	Cost Yes/No	Amendment Needed Yes/No	TAG Comments/ Recommendation
	<p>C954—2018 Specification for Steel Drill Screws for the Application of Gypsum Panel Products or Metal Plaster Bases to Steel Studs from 0.033 in (0.84 mm) or to 0.112 in. (2.84 mm) in Thickness R505.2.5R603.2.5R702.3.5.1R804.2.5</p> <p>C957/C957M—2017 Specification for High-Solids Content, Cold Liquid-Applied Elastomeric Waterproofing Membrane with Integral Wearing Surface R905.14.2</p> <p>C1002—20 Specification for Steel Self-Piercing Tapping Screws for the Application of Gypsum Panel Products or Metal Plaster Bases to Wood Studs or Steel Studs R702.3.1R702.3.5.1</p> <p>C1029—20 Specification for Spray-Applied Rigid Cellular Polyurethane Thermal Insulation R905.13.2</p> <p>C1032—2018 Specification for Woven Wire Plaster Base R702.2.1R702.2.2</p> <p>C1047—19 Specification for Accessories for Gypsum Wallboard and Gypsum Veneer Base R702.2.1R702.2.2R702.3.1</p> <p>C1063—21 Specification for Installation of Lathing and Furring to Receive Interior and Exterior Portland Cement-Based Plaster R702.2.2R703.7R703.7.1</p> <p>C1088—20 Standard Specification for Thin Veneer Brick Units Made from Clay or Shale R606.2.2</p> <p>C1107/C1107M—20 Standard Specification for Packaged Dry, Hydraulic-Cement Grout (Nonshrink) R402.3.1</p> <p>C1116/C116M—10(2015) Standard Specification for Fiber-Reinforced Concrete and Shotcrete R402.3.1</p>				

2024 Code Section	TITLE OR SUBJECT	Reviewer Comments	Cost Yes/No	Amendment Needed Yes/No	TAG Comments/ Recommendation
	<p>C1157/C1157M—20a Standard Performance Specification for Hydraulic Cement R608.5.1.1R703.7.2 C1167—2011(2017) Specification for Clay Roof Tiles R905.3.4 C1173—2018 Specification for Flexible Transition Couplings for Underground Piping Systems P3003.3.1P3003.5P3003.9.1P3003.10P3003.12.2P3003.13 C1177/C1177M—2017 Specification for Glass Mat Gypsum Substrate for Use as Sheathing R702.3.1Table R906.2 C1178/C1178M—2018 Specification for Glass Mat Water-Resistant Gypsum Backing Panel R702.3.1R702.3.7Table R702.4.2 C1186—2008(2016) Specification for Flat Fiber Cement Sheets R703.10.1R703.10.2 C1261—2013(2017)E1 Specification for Firebox Brick for Residential Fireplaces R1001.5R1001.8 C1277—20 Specification for Shielded Couplings Joining Hubless Cast Iron Soil Pipe and Fittings P3003.4.3 C1278/C1278M—2017 Specification for Fiber-Reinforced Gypsum Panels R702.3.1R702.3.7Table R702.4.2Table R906.2 C1280—18 Specification for Application of Exterior Gypsum Panel Products for Use as Sheathing Table R602.3(1) C1283—2015(2021) Practice for Installing Clay Flue Lining</p>				

2024 Code Section	TITLE OR SUBJECT	Reviewer Comments	Cost Yes/No	Amendment Needed Yes/No	TAG Comments/ Recommendation
R1003.9.1R1003.12 C1288—2017 C1289—22 C1313/C1313M—13(2019) C1325—21 C1328/C1328M—19 C1363—19 C1364—19 C1371—15(2022) C1396/C1396M—2017 C1405—20a C1440—21	<p>Standard Specification for Fiber-Cement Interior Substrate Sheets Table R503.2.1.1(1)Table R503.2.1.1(2)Table R602.3(2)Table R702.4.2</p> <p>Standard Specification for Faced Rigid Cellular Polyisocyanurate Thermal Insulation Board R303.8Table R703.15.1Table R703.15.2Table R703.16.1Table R703.16.2Table R906.2</p> <p>Standard Specification for Sheet Radiant Barriers for Building Construction Applications</p> <p>Standard Specification for Fiber-Mat Reinforced Cementitious Backer Units Table R702.4.2</p> <p>Specification for Plastic (Stucco) Cement R702.2.2R703.7.2</p> <p>The Standard Test Method for Thermal Performance of Building Materials and Envelope Assemblies by Means of a Hot Box Apparatus N1101.10.4.1</p> <p>Standard Specification for Architectural Cast Stone R606.2.5</p> <p>Standard Test Method for Determination of Emittance of Materials Near Room Temperature Using Portable Emissometers Table N1107.2N1108.2.1.3</p> <p>Specification for Gypsum Board Table R602.3(1)R702.2.1R702.2.2R702.3.1R702.3.7</p> <p>Standard Specification for Glazed Brick (Single Fired, Brick Units) R606.2.2</p>				

2024 Code Section	TITLE OR SUBJECT	Reviewer Comments	Cost Yes/No	Amendment Needed Yes/No	TAG Comments/ Recommendation
	<p>Specification for Thermoplastic Elastomeric (TPE) Gasket Materials for Drain, Waste and Vent (DWV), Sewer, Sanitary and Storm Plumbing Systems P3003.13 C1460—21</p> <p>Specification for Shielded Transition Couplings for Use with Dissimilar DWV Pipe and Fittings Above Ground P3003.13 C1461—21</p> <p>Specification for Mechanical Couplings Using Thermoplastic Elastomeric (TPE) Gaskets for Joining Drain, Waste and Vent (DWV) Sewer, Sanitary and Storm Plumbing Systems for Above and Below Ground Use P3003.13 C1492—2003(2016): Specification for Concrete Roof Tile R905.3.5 C1513—2018</p> <p>Standard Specification for Steel Tapping Screws for Cold-Formed Steel Framing Connections R505.2.5R603.2.5R702.3.5.1Table R703.3(2)Table R703.16.1Table R703.16.2R804.2.5 C1540—20</p> <p>Specification for Heavy-Duty Shielded Couplings Joining Hubless Cast Iron Soil Pipe and Fittings P3003.4.3 C1549—16 (2022)</p> <p>Standard Test Method for Determination of Solar Reflectance Near Ambient Temperature Using a Portable Solar Reflectometer Table N1107.2N1108.2.1.3N1108.2.1.3.1 C1634—20</p> <p>Standard Specification for Concrete Facing Brick and Other Concrete Masonry Facing Units R606.2.1 C1658/C1658M—19e1</p> <p>Standard Specification for Glass Mat Gypsum Panels R702.3.1 C1668—20</p> <p>Standard Specification for Externally Applied Reflective Insulation Systems on Rigid Duct in Heating, Ventilation, and Air Conditioning (HVAC) Systems M1601.3</p>				

2024 Code Section	TITLE OR SUBJECT	Reviewer Comments	Cost Yes/No	Amendment Needed Yes/No	TAG Comments/ Recommendation
	<p>C1670/1670M—21b Standard Specification for Adhered Manufactured Stone Masonry Veneer Units R606.2.6</p> <p>C1691—2021 Standard Specification for Unreinforced Autoclaved Aerated Concrete (AAC) Masonry Units R606.2.3</p> <p>C1693—2011(2017) Standard Specification for Autoclaved Aerated Concrete (AAC) R606.2.3</p> <p>C1743—2019 Standard Practice for Installation and Use of Radiant Barrier Systems (RBS) in Residential Building Construction N1101.11.2N1102.3</p> <p>C1766—2015(2019) Standard Specification for Factory-Laminated Gypsum Panel Products R702.3.1</p> <p>C1902—20 Standard Specification for Cellular Glass Insulation Used in Building and Roof Applications TABLE R906.2</p> <p>D41/D41M—2011(2016) Specification for Asphalt Primer Used in Roofing, Dampproofing and Waterproofing Table R905.9.2Table R905.11.2</p> <p>D43/D43M—2000(2018) Specification for Coal Tar Primer Used in Roofing, Dampproofing and Waterproofing Table R905.9.2</p> <p>D226/D226M—2017 Specification for Asphalt-Saturated Organic Felt Used in Roofing and Waterproofing R703.2R905.1.1Table R905.1.1(1)R905.8.4Table R905.9.2</p> <p>D227/D227M—2003(2018) Specification for Coal-Tar-Saturated Organic Felt Used in Roofing and Waterproofing Table R905.9.2</p> <p>D312/D312M—2016a Specification for Asphalt Used in Roofing</p>				

2024 Code Section	TITLE OR SUBJECT	Reviewer Comments	Cost Yes/No	Amendment Needed Yes/No	TAG Comments/ Recommendation
	<p>Table R905.9.2 D422—63(2007)E2 Test Method for Particle-Size Analysis of Soils R403.1.8.1 D449/D449M—03(2021) Specification for Asphalt Used in Dampproofing and Waterproofing R406.2 D450/D450M—2017(2018) Specification for Coal-Tar Pitch Used in Roofing, Dampproofing and Waterproofing Table R905.9.2 D1227—13(2019)e1 Specification for Emulsified Asphalt Used as a Protective Coating for Roofing Table R905.9.2Table R905.11.2R905.14.2Table R909.2 D1248—2016 Specification for Polyethylene Plastics Extrusion Materials for Wire and Cable M1601.1.2 D1527—99(2005) Specification for Acrylonitrile-Butadiene-Styrene (ABS) Plastic Pipe, Schedules 40 and 80 Table P2906.4 D1693—21 Test Method for Environmental Stress-Cracking of Ethylene Plastics Table M2101.1 D1784—20 Standard Classification System and Basis for Rigid Poly(Vinyl Chloride) (PVC) Compounds and Chlorinated Poly(Vinyl Chloride) (CPVC) Compounds M1601.1.2 D1785—21a Specification for Poly (Vinyl Chloride) (PVC) Plastic Pipe, Schedules 40, 80 and 120 Table P2906.4 D1863/D1863M—2005(2018) Specification for Mineral Aggregate Used on Built-Up Roofs Table R905.9.2</p>				

2024 Code Section	TITLE OR SUBJECT	Reviewer Comments	Cost Yes/No	Amendment Needed Yes/No	TAG Comments/ Recommendation
	<p>D1869—15 Specification for Rubber Rings for Fiber-Reinforced Cement Pipe P2906.18P3003.13 D1970/D1970M—21 Specification for Self-adhering Polymer Modified Bitumen Sheet Materials Used as Steep Roof Underlayment for Ice Dam Protection R905.1.1Table R905.1.1(1)Table R905.1.1(2)R905.2.8.2R905.11.2.1 D2104—03 Specification for Polyethylene (PE) Plastic Pipe, Schedule 40 Table P2906.4 D2178/D2178M—15A(2021) Specification for Asphalt Glass Felt Used in Roofing and Waterproofing Table R905.9.2 D2235—2021 Specification for Solvent Cement for Acrylonitrile-Butadiene-Styrene (ABS) Plastic Pipe and Fittings P2906.9.1.1P3003.3.2 D2239—21 Specification for Polyethylene (PE) Plastic Pipe (SIDR-PR) Based on Controlled Inside Diameter Table P2906.4 D2241—20 Specification for Poly (Vinyl Chloride) (PVC) Pressure-Rated Pipe (SDR-Series) Table P2906.4 D2282—99(2005) Specification for Acrylonitrile-Butadiene-Styrene (ABS) Plastic Pipe (SDR-PR) Table P2906.4 D2412—21 Test Method for Determination of External Loading Characteristics of Plastic Pipe by Parallel-Plate Loading M1601.1.2 D2447—03 Specification for Polyethylene (PE) Plastic Pipe Schedules 40 and 80, Based on Outside Diameter Table M2101.1 D2464—15 Standard Specification for Threaded Poly (Vinyl Chloride) (PVC) Plastic Pipe Fittings, Schedule 80</p>				

2024 Code Section	TITLE OR SUBJECT	Reviewer Comments	Cost Yes/No	Amendment Needed Yes/No	TAG Comments/ Recommendation
	<p>Table P2906.6 D2466—21 Standard Specification for Poly (Vinyl Chloride) (PVC) Plastic Pipe Fittings, Schedule 40</p> <p>Table P2906.6 D2467—20 Standard Specification for Poly (Vinyl Chloride) (PVC) Plastic Pipe Fittings, Schedule 80</p> <p>Table P2906.6 D2468—96a Specification for Acrylonitrile-Butadiene-Styrene (ABS) Plastic Pipe Fittings, Schedule 40</p> <p>Table P2906.6 D2513—20 Specification for Polyethylene (PE) Gas Pressure Pipe, Tubing and Fittings</p> <p>Table M2101.1G2414.6G2415.17.2 D2564—20 Specification for Solvent Cements for Poly (Vinyl Chloride) (PVC) Plastic Piping Systems P2906.9.1.4P3003.9.2</p> <p>D2609—21 Specification for Plastic Insert Fittings for Polyethylene (PE) Plastic Pipe</p> <p>Table P2906.6 D2626/D2626M—04 (2020) Specification for Asphalt-Saturated and Coated Organic Felt Base Sheet Used in Roofing R905.1.1Table R905.1.1(1)Table R905.9.2 D2657—2007(2015) Standard Practice for Heat Fusion Joining of Polyolefin Pipe Fittings M2105.11.1P2906.3.1P2906.20.2P3003.12.1</p> <p>D2661—21 Specification for Acrylonitrile-Butadiene-Styrene (ABS) Schedule 40 Plastic Drain, Waste, and Vent Pipe and Fittings</p> <p>Table P3002.1(1)Table P3002.1(2)Table P3002.2Table P3002.3P3003.3.2 D2665—20 Specification for Poly (Vinyl Chloride) (PVC) Plastic Drain, Waste, and Vent Pipe and Fittings Table P3002.1(1)Table P3002.1(2)Table P3002.2Table P3002.3</p> <p>D2672—20e1</p>				

2024 Code Section	TITLE OR SUBJECT	Reviewer Comments	Cost Yes/No	Amendment Needed Yes/No	TAG Comments/ Recommendation
	Standard Specification for Joints for IPS PVC Pipe Using Solvent Cement Table P2906.4 D2680—20				
	Standard Specification for Acrylonitrile-Butadiene-Styrene (ABS) and Poly(Vinyl Chloride) (PVC) Composite Sewer Piping Table P3002.2 D2683—20				
	Standard Specification for Socket-Type Polyethylene Fittings for Outside Diameter-Controlled Polyethylene Pipe and Tubing Table M2105.5M2105.11.1P2906.20.2P3002.3P3010.5 D2729—21				
	Specification for Poly (Vinyl Chloride) (PVC) Sewer Pipe and Fittings P3009.11Table P3302.1 D2737—21				
	Standard Specification for Polyethylene (PE) Plastic Tubing Table P2906.4 D2751—05				
	Specification for Acrylonitrile-Butadiene-Styrene (ABS) Sewer Pipe and Fittings Table P3002.2Table P3002.3 D2822/D2822M—2005(2011)e1				
	Specification for Asphalt Roof Cement, Asbestos Containing Table R905.9.2 D2823/D2823M—05(2011)e1				
	Specification for Asphalt Roof Coatings, Asbestos Containing Table R905.9.2Table R909.2 D2824/D2824M—2018				
	Standard Specification for Aluminum-Pigmented Asphalt Roof Coatings, Nonfibered and Fibered without Asbestos Table R905.9.2Table R905.11.2Table R909.2 D2846/D2846M—19a				
	Standard Specification for Chlorinated Poly (Vinyl Chloride) (CPVC) Plastic Hot- and Cold-Water Distribution Systems Table M2101.1Table P2906.4Table P2906.5Table P2906.6P2906.9.1.2P2906.9.1.3 D2855—20				
	Standard Practice for the Two-Step (Primer and Solvent Cement) Method of Joining Poly (Vinyl Chloride) (PVC) or Chlorinated Poly (Vinyl Chloride) (CPVC) Pipe and Piping Components with Tapered Sockets				

2024 Code Section	TITLE OR SUBJECT	Reviewer Comments	Cost Yes/No	Amendment Needed Yes/No	TAG Comments/ Recommendation
<p>P2906.9.1.3P3003.9.2 D2898—2010(2017) Test Methods for Accelerated Weathering of Fire-Retardant-Treated Wood for Fire Testing R302.15.4R302.15.8 D2949—18 Specification for 3.25-in. Outside Diameter Poly (Vinyl Chloride) (PVC) Plastic Drain, Waste and Vent Pipe and Fittings Table P3002.1(1)Table P3002.1(2)Table P3002.2Table P3002.3 D3019/D3019—2017 Specification for Lap Cement Used with Asphalt Roll Roofing, Nonfibered, Asbestos Fibered and Nonasbestos Fibered Table R905.9.2Table R905.11.2 D3034—21 Specification for Type PSM Poly (Vinyl Chloride) (PVC) Sewer Pipe and Fittings Table P3002.2Table P3002.3 D3035—21 Specification for Polyethylene (PE) Plastic Pipe (DR-PR) Based on Controlled Outside Diameter Table M2105.4 D3138—2021 Standard Specification for Solvent Cements for Transition Joints Between Acrylonitrile-Butadiene-Styrene (ABS) and Poly (Vinyl Chloride) (PVC) Non-Pressure Piping Components P3003.13.4 D3161/D3161M—20 Test Method for Wind Resistance of Steep Slope Roofing Products (Fan-Induced Method) R905.2.4.1Table R905.2.4.1R905.4.4.1R905.6.5Table R905.6.5R905.15.6 D3201/D3201M—20 Test Method for Hygroscopic Properties of Fire-Retardant Wood and Wood-Base Products R302.15.9 D3212—2021 Specification for Joints for Drain and Sewer Plastic Pipes Using Flexible Elastomeric Seals P3003.3.1P3003.9.1P3003.12.2 D3261—2016 Specification for Butt Heat Fusion Polyethylene (PE) Plastic Fittings for Polyethylene (PE) Plastic Pipe and Tubing Table M2101.1Table M2105.5M2105.11.1M2105.13.3P2906.20.2</p>					

2024 Code Section	TITLE OR SUBJECT	Reviewer Comments	Cost Yes/No	Amendment Needed Yes/No	TAG Comments/ Recommendation
	<p>D3309—96a(2002) Specification for Polybutylene (PB) Plastic Hot- and Cold-Water Distribution System Table M2101.1</p> <p>D3311—2017(2021) Specification for Drain, Waste and Vent (DWV) Plastic Fittings Patterns P3002.3</p> <p>D3350—21 Specification for Polyethylene Plastic Pipe and Fitting Materials Table M2101.1</p> <p>D3462/D3462M—19 Specification for Asphalt Shingles Made from Glass Felt and Surfaced with Mineral Granules R905.2.4</p> <p>D3468/D3468M—99 (2020) Specification for Liquid-Applied Neoprene and Chlorosulfonated Polyethylene Used in Roofing and Waterproofing R905.14.2</p> <p>D3679—21 Specification for Rigid Poly (Vinyl Chloride) (PVC) Siding R703.11</p> <p>D3737—2018E1 Practice for Establishing Allowable Properties for Structural Glued Laminated Timber (Glulam) R502.1.3R602.1.3R802.1.2</p> <p>D3747—79(2007) Specification for Emulsified Asphalt Adhesive for Adhering Roof Insulation Table R905.9.2Table R905.11.2</p> <p>D3909/D3909M—14(2021) Specification for Asphalt Roll Roofing (Glass Felt) Surfaced with Mineral Granules R905.2.8.2R905.5.4Table R905.9.2</p> <p>D4022/D4022M—07(2012)e1 Specification for Coal Tar Roof Cement, Asbestos Containing Table R905.9.2</p> <p>D4068—2017(2022) Specification for Chlorinated Polyethylene (CPE) Sheeting for Concealed Water Containment Membrane</p>				

2024 Code Section	TITLE OR SUBJECT	Reviewer Comments	Cost Yes/No	Amendment Needed Yes/No	TAG Comments/ Recommendation
<p>P2709.2P2709.2.2 D4318—2017e1 Test Methods for Liquid Limit, Plastic Limit and Plasticity Index of Soils R403.1.8.1 D4434/D4434M—21 Specification for Poly (Vinyl Chloride) Sheet Roofing Table R905.12 D4479/D4479M—2007(2018) Specification for Asphalt Roof Coatings—Asbestos-Free Table R905.9.2Table R909.2 D4551—2017 Specification for Poly (Vinyl Chloride) (PVC) Plastic Flexible Concealed Water-Containment Membrane P2709.2P2709.2.1 D4586/D4586M—2007(2018) Specification for Asphalt Roof Cement—Asbestos-Free Table R905.9.2 D4601/D4601M—04(2020) Specification for Asphalt-Coated Glass Fiber Base Sheet Used in Roofing Table R905.9.2R905.11.2.1 D4637/D4637M—2015(2021) Specification for EPDM Sheet Used in Single-Ply Roof Membrane Table R905.12 D4829—21 Test Method for Expansion Index of Soils R403.1.8.1 D4869/D4869M—2016A(2021) Specification for Asphalt-Saturated (Organic Felt) Underlayment Used in Steep Slope Roofing R905.1.1Table R905.1.1(1) D4897/D4897M—2016 Specification for Asphalt-Coated Glass-Fiber Venting Base Sheet Used in Roofing Table R905.9.2 D4990—97a(2020)</p>					

2024 Code Section	TITLE OR SUBJECT	Reviewer Comments	Cost Yes/No	Amendment Needed Yes/No	TAG Comments/ Recommendation
	Specification for Coal-Tar Glass Felt Used in Roofing and Waterproofing Table R905.9.2 D5019—07a Specification for Reinforced Nonvulcanized Polymeric Sheet Used in Roofing Membrane Table R905.12 D5055—19e1 Specification for Establishing and Monitoring Structural Capacities of Prefabricated Wood I-Joists R502.1.2R802.1.7 D5456—21e1 Standard Specification for Evaluation of Structural Composite Lumber Products R502.1.5R602.1.5R802.1.4 D5516—2018 Test Method for Evaluating the Flexural Properties of Fire-Retardant-Treated Softwood Plywood Exposed to the Elevated Temperatures R302.15.6 D5643/D5643M—2006(2018) Specification for Coal Tar Roof Cement Asbestos-Free Table R905.9.2 D5664 — 2017 Test Methods for Evaluating the Effects of Fire-Retardant Treatments and Elevated Temperatures on Strength Properties of Fire-Retardant-Treated Lumber R302.15.7 D5665/D5665M—99a(2021) Specification for Thermoplastic Fabrics Used in Cold-Applied Roofing and Waterproofing Table R905.9.2 D5726—98(2020) Specification for Thermoplastic Fabrics Used in Hot-Applied Roofing and Waterproofing Table R905.9.2 D6083/D6083M—2021 Specification for Liquid-Applied Acrylic Coating Used in Roofing Table R905.9.2Table R905.11.2Table R905.13.3R905.14.2TABLE R909.2 D6162/D6162M—2021				

2024 Code Section	TITLE OR SUBJECT	Reviewer Comments	Cost Yes/No	Amendment Needed Yes/No	TAG Comments/ Recommendation
	Specification for Styrene Butadiene Styrene (SBS) Modified Bituminous Sheet Materials Using a Combination of Polyester and Glass Fiber Reinforcements Table R905.11.2 D6163/D6163M—2021 Specification for Styrene Butadiene Styrene (SBS) Modified Bituminous Sheet Materials Using Glass Fiber Reinforcements Table R905.11.2 D6164/D6164M—2021 Specification for Styrene Butadiene Styrene (SBS) Modified Bituminous Sheet Materials Using Polyester Reinforcements Table R905.11.2 D6222/D6222M—2016 Specification for Atactic Polypropylene (APP) Modified Bituminous Sheet Materials Using Polyester Reinforcements Table R905.11.2 D6223/D6223M—2021 Specification for Atactic Polypropylene (APP) Modified Bituminous Sheet Materials Using a Combination of Polyester and Glass Fiber Reinforcements Table R905.11.2 D6298—2016 Specification for Fiberglass Reinforced Styrene-Butadiene-Styrene (SBS) Modified Bituminous Sheets with a Factory Applied Metal Surface Table R905.11.2 D6305—21 Practice for Calculating Bending Strength Design Adjustment Factors for Fire-Retardant-Treated Plywood Roof Sheathing R302.15.6 D6380/D6380M—2003(2018) Standard Specification for Asphalt Roll Roofing (Organic Felt) R905.1.1Table R905.1.1(1)R905.2.8.2R905.5.4 D6464—2003A(2017) Standard Specification for Expandable Foam Adhesives for Fastening Gypsum Wallboard to Wood Framing R702.3.1.1 D6694/D6694M—08(2013)E1 Standard Specification for Liquid-Applied Silicone Coating Used in Spray Polyurethane Foam Roofing Systems Table R905.13.3R905.14.2Table R909.2				

2024 Code Section	TITLE OR SUBJECT	Reviewer Comments	Cost Yes/No	Amendment Needed Yes/No	TAG Comments/ Recommendation
	<p>D6754/D6754M—2015 Standard Specification for Ketone Ethylene Ester Based Sheet Roofing Table R905.12</p> <p>D6757/D6757M—2018 Specification for Underlayment Felt Containing Inorganic Fibers Used in Steep-Slope Roofing R905.1.1Table R905.1.1(1)</p> <p>D6841 — 21 Standard Practice for Calculating Design Value Treatment Adjustment Factors for Fire-Retardant-Treated Lumber R302.15.7</p> <p>D6878/D6878M—2021 Standard Specification for Thermoplastic Polyolefin-Based Sheet Roofing Table R905.12</p> <p>D6947/D6947M—2016 Standard Specification for Liquid Applied Moisture Cured Polyurethane Coating Used in Spray Polyurethane Foam Roofing System Table R905.13.3R905.14.2TABLE R909.2</p> <p>D7032—2021 Standard Specification for Establishing Performance Ratings for Wood-Plastic Composite and Plastic Lumber Deck Boards, Stair Treads, Guards, and Handrails R507.2.2R507.2.2.1R507.2.2.3R507.2.2.4</p> <p>D7158—D7158M—20 Standard Test Method for Wind Resistance of Asphalt Shingles (Uplift Force/Uplift Resistance Method) R905.2.4.1Table R905.2.4.1</p> <p>D7254—21 Standard Specification for Polypropylene (PP) Siding Table R703.3(1)R703.14</p> <p>D7425/D7425M—13(2019) Standard Specification for Spray Polyurethane Foam Used for Roofing Applications R905.13.2</p> <p>D7672—19 Standard Specification for Evaluating Structural Capacities of Rim Board Products and Assemblies R502.1.7R602.1.7R802.1.6</p> <p>D7793—20</p>				

2024 Code Section	TITLE OR SUBJECT	Reviewer Comments	Cost Yes/No	Amendment Needed Yes/No	TAG Comments/ Recommendation
	<p>Standard Specification for Insulated Vinyl Siding Table R703.3(1)R703.13 D8257/D8257M—20 Standard Specification for Mechanically Attached Polymeric Roof Underlayment Used in Steep Slope Roofing R905.1.1TABLE R905.1.1(1) E84—21a Standard Test Method for Surface Burning Characteristics of Building Materials R202R302.9.3R302.9.4R302.10.1R302.10.2R302.15R507.2.2.2R703.14.3M1601.3M1601.5.2P2801.5 E96/E96M—21 Standard Test Methods for Gravimetric Determination of Water Vapor Transmission Rate of Materials R202Table R806.5M1411.12M1601.4.6 E108—20a Standard Test Methods for Fire Tests of Roof Coverings R302.2.4R902.1 E119—20 Standard Test Methods for Fire Tests of Building Construction and Materials Table R302.1(1)Table R302.1(2)R302.2.1R302.2.2R302.3R302.4.1R302.11.1R606.2.2 E136—2022 Standard Test Method for Assessing Combustibility of Materials Using a Vertical Tube Furnace at 750 Degrees C R202R302.11 E283/E283M—19 Standard Test Method for Determining Rate of Air Leakage Through Exterior Windows, Skylights, Curtain Walls, and Doors Under Specified Pressure Differences Across the Specimen R202N1102.5.4 E330/E330M—14(2021) Test Method for Structural Performance of Exterior Windows, Doors, Skylights and Curtain Walls by Uniform Static Air Pressure Difference R609.4R609.5R609.6.2R703.1.2 E331—2000(2016) Test Method for Water Penetration of Exterior Windows, Skylights, Doors, and Curtain Walls by Uniform Static Air Pressure Difference R703.1.1 E408—13(2019)</p>				

2024 Code Section	TITLE OR SUBJECT	Reviewer Comments	Cost Yes/No	Amendment Needed Yes/No	TAG Comments/ Recommendation
	Standard Test Methods for Total Normal Emittance of Surfaces Using Inspection-Meter Techniques Table N1107.2N1108.2.1.3 E779—19 Standard Test Method for Determining Air Leakage Rate by Fan Pressurization N1102.5.1.2N1102.5.1.3 E814—2013A(2017) Standard Test Method for Fire Tests of Penetration Firestop Systems R302.4.1.2 E903—20 Standard Test Method for Solar Absorptance, Reflectance and Transmittance of Materials Using Integrating Spheres (Withdrawn 2005) Table N1107.2N1108.2.1.3N1108.2.1.3.1 E970—2017 Standard Test Method for Critical Radiant Flux of Exposed Attic Floor Insulation Using a Radiant Heat Energy Source R302.10.4 E1509—2012(2017) Standard Specification for Room Heaters, Pellet Fuel-Burning Type M1410.1 E1554/E1554 M—13(2018) Standard Test Methods for Determining Air Leakage of Air Distribution Systems by Fan Pressurization Table N1105.4.2(1)N1103.3.7N1103.3.8 E1592—2005(2017) Test Method for Structural Performance of Sheet Metal Roof and Siding Systems by Uniform Static Air Pressure Difference R905.10.5 E1602—2003(2017) Guide for Construction of Solid Fuel Burning Masonry Heaters R1002.2 E1745—17 Standard Specification for Plastic Water Vapor Retarders Used in Contact with Soil or Granular Fill under Concrete Slabs R506.3.3 E1827—11(2017) Standard Test Methods for Determining Airtightness of Buildings Using an Orifice Blower Door N1102.5.1.2				

2024 Code Section	TITLE OR SUBJECT	Reviewer Comments	Cost Yes/No	Amendment Needed Yes/No	TAG Comments/ Recommendation
E1886—19	Standard Test Method for Performance of Exterior Windows, Curtain Walls, Doors, and Impact Protective Systems Impacted by Missile(s) and Exposed to Cyclic Pressure Differentials R301.2.1.2R609.6.1R609.6.2Table R703.11.2				
E1918—21	Standard Test Method for Measuring Solar Reflectance of Horizontal and Low-Sloped Surfaces in the Field Table N1107.2N1108.2.1.3N1108.2.1.3.1				
E1980—11(2019)	Standard Practice for Calculating Solar Reflectance of Horizontal and Low-sloped Opaque Surfaces Table N1107.2N1108.2.1.3				
E1996—20	Specification for Performance of Exterior Windows, Curtain Walls, Doors, and Impact Protective Systems Impacted by Windborne Debris in Hurricanes R301.2.1.2R609.6.1R609.6.2				
E2178—21a	Standard Test Method for Determining Air Leakage Rate and Calculation of Air Permeance of Building Materials R202N1101.10.5				
E2231—21	Standard Practice for Specimen Preparation and Mounting of Pipe and Duct Insulation Materials to Assess Surface Burning Characteristics M1601.3				
E2273—2018	Standard Test Method for Determining the Drainage Efficiency of Exterior Insulation and Finish Systems (EIFS) Clad Wall Assemblies R703.9.2				
E2556/E2556M—2010(2016)	Standard Specification for Vapor Permeable Flexible Sheet Water-resistive Barriers Intended for Mechanical Attachment R703.2				
E2568—2017A	Standard Specification for PB Exterior Insulation and Finish Systems R703.9.1R703.9.2				
E2570/E2570M—07(2019)					

2024 Code Section	TITLE OR SUBJECT	Reviewer Comments	Cost Yes/No	Amendment Needed Yes/No	TAG Comments/ Recommendation
	<p>Standard Test Methods for Evaluating Water-Resistive Barrier (WRB) Coatings Used under Exterior Insulation and Finish Systems (EIFS) or EIFS with Drainage R703.9.2 E2634—2018 Standard Specification for Flat Wall Insulating Concrete Form (ICF) Systems R404.1.3.3.6.1R608.4.4 E2925—19a Standard Specification for Manufactured Polymeric Drainage and Ventilation Materials Used to Provide a Rainscreen Function R703.7.3.2 E3158—18 Standard Test Method for Measuring the Air Leakage Rate of a Large or Multizone Building N1102.5.1.2 F405—05 Specification for Corrugated Polyethylene (PE) Pipe and Fittings Table P3009.11Table P3302.1 F409—2017 Specification for Thermoplastic Accessible and Replaceable Plastic Tube and Tubular Fittings Table P2701.1P2702.2P2702.3 F437—21 Standard Specification for Threaded Chlorinated Poly (Vinyl Chloride) (CPVC) Plastic Pipe Fittings, Schedule 80 Table P2906.6 F438—2017 Standard Specification for Socket-Type Chlorinated Poly (Vinyl Chloride) (CPVC) Plastic Pipe Fittings, Schedule 40 Table P2906.6 F439—19 Standard Specification for Socket Type Chlorinated Poly (Vinyl Chloride) (CPVC) Plastic Pipe Fittings, Schedule 80 Table P2906.6 F441/F441M—20 Specification for Chlorinated Poly (Vinyl Chloride) (CPVC) Plastic Pipe, Schedules 40 and 80 Table P2906.4Table P2906.5 F442/F442M—20 Specification for Chlorinated Poly (Vinyl Chloride) (CPVC) Plastic Pipe (SDR-PR)</p>				

2024 Code Section	TITLE OR SUBJECT	Reviewer Comments	Cost Yes/No	Amendment Needed Yes/No	TAG Comments/ Recommendation
	<p>Table P2906.4Table P2906.5 F477—14(2021) Specification for Elastomeric Seals (Gaskets) for Joining Plastic Pipe P2906.18P3003.13 F493—20 Specification for Solvent Cements for Chlorinated Poly (Vinyl Chloride) (CPVC) Plastic Pipe and Fittings P2906.9.1.2P2906.9.1.3P2906.18.2 F628—2012E2 Specification for Acrylonitrile-Butadiene-Styrene (ABS) Schedule 40 Plastic Drain, Waste, and Vent Pipe with a Cellular Core Table P3002.1(1)Table P3002.1(2)Table P3002.2Table P3002.3P3003.3.2 F656—21 Specification for Primers for Use in Solvent Cement Joints of Poly(Vinyl Chloride) (PVC) Plastic Pipe and Fittings P2906.9.1.4P3003.9.2 F667/F667M—16(2021) Standard Specification for 3 through 24 in. Corrugated Polyethylene Pipe and Fittings Table P3009.11Table P3302.1 F714—21a Standard Specification for Polyethylene (PE) Plastic Pipe (SDR-PR) Based on Outside Diameter Table P3002.1(2)Table P3002.2P3010.4 F844—19 Standard Specification for Washers, Steel, Plain (Flat), Unhardened for General Use Table R507.2.3 F876—20b Standard Specification for Crosslinked Polyethylene (PEX) Tubing Table M2101.1Table P2906.4Table P2906.5 F877—20 Standard Specification for Crosslinked Polyethylene (PEX) Plastic Hot- and Cold-Water Distribution Systems Table M2101.1Table P2906.6 F891—2016 Standard Specification for Coextruded Poly(Vinyl Chloride) (PVC) Plastic Pipe with a Cellular Core Table P3002.1(1)Table P3002.1(2)Table P3002.2Table P3302.1 F1055—2016A</p>				

2024 Code Section	TITLE OR SUBJECT	Reviewer Comments	Cost Yes/No	Amendment Needed Yes/No	TAG Comments/ Recommendation
	<p>Standard Specification for Electrofusion Type Polyethylene Fittings for Outside Diameter Controlled Polyethylene and Crosslinked Polyethylene Pipe and Tubing Table M2105.5M2105.11.2P2906.20.2 F1281—2017(2021)e1</p> <p>Standard Specification for Crosslinked Polyethylene/Aluminum/Crosslinked Polyethylene (PEX-AL-PEX) Pressure Pipe Table M2101.1Table P2906.4Table P2906.5Table P2906.6P2906.12.1 F1282—2017</p> <p>Specification for Polyethylene/Aluminum/Polyethylene (PE-AL-PE) Composite Pressure Pipe Table M2101.1Table P2906.4Table P2906.5Table P2906.6P2906.12.1 F1412—2016</p> <p>Specification for Polyolefin Pipe and Fittings for Corrosive Waste Drainage Table P3002.1(2)Table P3002.2Table P3002.3P3003.11.1 F1488—14(2019)</p> <p>Standard Specification for Coextruded Composite Pipe Table P3002.1(1)Table P3002.1(2)Table P3002.2Table P3009.11 F1504—21</p> <p>Standard Specification for Folded Poly (Vinyl Chloride) (PVC) for Existing Sewer and Conduit Rehabilitation P3011.4 F1554—20</p> <p>Specification for Anchor Bolts, Steel, 36, 55 and 105-ksi Yield Strength R608.5.2.2 F1667—21a</p> <p>Specification for Driven Fasteners: Nails, Spikes, and Staples Table R507.2.3Table R602.3(1)R703.3.3R703.6.3Table R703.15.1Table R703.15.2R905.2.5 F1807—19b</p> <p>Standard Specification for Metal Insert Fittings Utilizing a Copper Crimp Ring, or Alternate Stainless Steel Clamps, for SDR9 Cross-Linked Polyethylene (PEX) Tubing and SDR9 Polyethylene of Raised Temperature (PE-RT) Tubing Table M2101.1Table P2906.6 F1866—2018</p> <p>Specification for Poly (Vinyl Chloride) (PVC) Plastic Schedule 40 Drainage and DWV Fabricated Fittings Table P3002.3 F1871—20</p>				

2024 Code Section	TITLE OR SUBJECT	Reviewer Comments	Cost Yes/No	Amendment Needed Yes/No	TAG Comments/ Recommendation
	<p data-bbox="201 285 1709 315">Standard Specification for Folded/Formatted Poly (Vinyl Chloride) Pipe Type A for Existing Sewer and Conduit Rehabilitation</p> <p data-bbox="201 321 310 350">P3011.4</p> <p data-bbox="201 357 340 386">F1924—19</p> <p data-bbox="201 393 1871 456">Standard Specification for Plastic Mechanical Fittings for Use on Outside Diameter Controlled Polyethylene Gas Distribution Pipe and Tubing</p> <p data-bbox="201 462 354 492">M2105.11.1</p> <p data-bbox="201 498 340 527">F1960—21</p> <p data-bbox="201 534 1793 597">Standard Specification for Cold Expansion Fittings with PEX Reinforcing Rings for Use with Cross-Linked Polyethylene (PEX) and Polyethylene of Raised Temperature (PE-RT) Tubing</p> <p data-bbox="201 604 564 633">Table M2101.1 Table P2906.6</p> <p data-bbox="201 639 340 669">F1970—19</p> <p data-bbox="201 675 1850 738">Standard Specification for Special Engineered Fittings, Appurtenances or Valves for Use in Poly (Vinyl Chloride) (PVC) or Chlorinated Poly (Vinyl Chloride) (CPVC) Systems</p> <p data-bbox="201 745 588 774">Table M2105.5 Table P2903.9.4</p> <p data-bbox="201 781 340 810">F1973—21</p> <p data-bbox="201 816 1850 880">Standard Specification for Factory Assembled Anodeless Risers and Transition Fittings in Polyethylene (PE) and Polyamide 11 (PA11) and Polyamide 12 (PA12) Fuel Gas Distribution Systems</p> <p data-bbox="201 886 354 915">G2415.17.2</p> <p data-bbox="201 922 422 951">F1974—09(2020)</p> <p data-bbox="201 958 1856 1021">Specification for Metal Insert Fittings for Polyethylene/Aluminum/Polyethylene and Crosslinked Polyethylene/Aluminum/Crosslinked Polyethylene Composite Pressure Pipe</p> <p data-bbox="201 1027 522 1057">Table P2906.6 P2906.12.1</p> <p data-bbox="201 1063 453 1092">F1986—2001(2011)</p> <p data-bbox="201 1099 1806 1128">Specification for Multilayer Pipe Type 2, Compression Fittings, and Compression Joints for Hot and Cold Drinking-Water Systems</p> <p data-bbox="201 1135 732 1164">Table P2906.4 Table P2906.5 Table P2906.6</p> <p data-bbox="201 1170 340 1200">F2080—19</p> <p data-bbox="201 1206 1883 1269">Standard Specification for Cold-Expansion Fittings with Metal Compression-Sleeves for Crosslinked Polyethylene (PEX) Pipe and SDR9 Polyethylene of Raised Temperature (PE-RT) Pipe</p> <p data-bbox="201 1276 382 1305">Table P2906.6</p> <p data-bbox="201 1312 340 1341">F2090—21</p> <p data-bbox="201 1347 1501 1377">Specification for Window Fall Prevention Devices with Emergency Escape (Egress) Release Mechanisms</p> <p data-bbox="201 1383 543 1412">R319.1.1 R321.2.1 R321.2.2</p>				

2024 Code Section	TITLE OR SUBJECT	Reviewer Comments	Cost Yes/No	Amendment Needed Yes/No	TAG Comments/ Recommendation
F2098—18	Standard Specification for Stainless Steel Clamps for Securing SDR9 Cross-Linked Polyethylene (PEX) Tubing and SDR9 Polyethylene of Raised Temperature (PE-RT) to Metal Insert and Plastic Insert Fittings Table M2101.1 Table P2906.6				
F2159—21	Standard Specification for Plastic Insert Fittings Utilizing a Copper Crimp Ring, or Alternate Stainless Steel Clamps for SDR9 Crosslinked Polyethylene (PEX) Tubing and SDR9 Polyethylene of Raised Temperature (PE-RT) Tubing Table P2906.6				
F2262—09	Specification for Crosslinked Polyethylene/Aluminum/Crosslinked Polyethylene Tubing OD Controlled SDR9 Table P2906.4 Table P2906.5				
F2389—21	Standard Specification for Pressure-Rated Polypropylene (PP) Piping Systems Table P2906.4 Table P2906.5 Table P2906.6 P2906.11.1				
F2434—19	Standard Specification for Metal Insert Fittings Utilizing a Copper Crimp Ring for SDR9 Cross-Linked Polyethylene (PEX) Tubing and SDR9 Cross-Linked Polyethylene/Aluminum/Cross-Linked Polyethylene (PEX AL-PEX) Tubing Table P2906.6				
F2623—22	Standard Specification for Polyethylene of Raised Temperature (PE-RT) Systems for Non-Potable Water Applications Table M2101.1				
F2735—21	Standard Specification for Plastic Insert Fittings for SDR9 Cross-Linked Polyethylene (PEX) and Polyethylene of Raised Temperature (PE-RT) Tubing Table M2101.1 Table P2906.6				
F2769—18	Standard Specification for Polyethylene of Raised Temperature (PE-RT) Plastic Hot- and Cold-Water Tubing and Distribution Systems Table M2101.1 Table P2906.4 Table P2906.5 Table P2906.6				
F2806—20	Standard Specification for Acrylonitrile-Butadiene-Styrene (ABS) Plastic Pipe (Metric SDR-PR) Table M2101.1				
F2855—19					

2024 Code Section	TITLE OR SUBJECT	Reviewer Comments	Cost Yes/No	Amendment Needed Yes/No	TAG Comments/ Recommendation
	<p>Standard Specification for Chlorinated Poly(Vinyl Chloride)/Aluminum/Chlorinated Poly(Vinyl Chloride) (CPVC-AL-CPVC) Composite Pressure Tubing Table P2906.4Table P2906.5 F2945—2018 Standard Specification for Polyamide 11 Gas Pressure Pipe, Tubing and Fittings G2414.6 F2969—12(2020) Standard Specification for Acrylonitrile-Butadiene-Styrene (ABS) IPS Dimensioned Pressure Pipe Table M2101.1 F3226/F3226M—19 Standard Specification for Metallic Press-Connect Fittings for Piping and Tubing Systems Table P2906.6 F3253—19 Standard Specification for Crosslinked Polyethylene (PEX) Tubing with Oxygen Barrier for Hot- and Cold-Water Hydronic Distribution Systems Table M2101.1 F3328—19 Standard Practice for the One-Step (Solvent Cement Only) Method of Joining Poly (Vinyl Chloride) (PVC) or Chlorinated Poly (Vinyl Chloride) (CPVC) Pipe and Piping Components with Tapered Sockets Table M2101.1P2906.9.1.3 F3347—20a Standard Specification for Metal Press Insert Fittings with Factory Assembled Stainless Steel Press Sleeve for SDR9 Cross-Linked Polyethylene (PEX) Tubing and SDR9 Polyethylene of Raised Temperature (PE-RT) Tubing Table M2101.1 F3348—20b Standard Specification for Plastic Press Insert Fittings with Factory Assembled Stainless Steel Press Sleeve for SDR9 Cross-Linked Polyethylene (PEX) Tubing and SDR9 Polyethylene of Raised Temperature (PE-RT) Tubing Table M2101.1 F3371—19 Standard Specification for Polyolefin Pipe and Fittings for Drainage, Waste, and Vent Applications Table P3002.1(1)Table P3002.1(2)Table P3002.2P3003.11.1</p>				

2024 Code Section	TITLE OR SUBJECT	Reviewer Comments	Cost Yes/No	Amendment Needed Yes/No	TAG Comments/ Recommendation
AWC	American Wood Council			NO	
<p>ANSI/AWC NDS—2024 National Design Specification (NDS) for Wood Construction—with 2018 Supplement R404.2.2R502.2Table R503.1R507.2.1R602.3R608.9.2R608.9.3Table R703.15.1Table R703.15.2R802.2</p> <p>ANSI/AWC PWF—2021 Permanent Wood Foundation Design Specification R304.3.2R401.1R404.2.3</p> <p>ANSI/AWC WFCM—2024 Wood Frame Construction Manual for One- and Two-Family Dwellings R301.1.1R301.2.1.1R602.10.8.2Figure R608.9(9)R608.9.2R608.9.3R608.10</p> <p>AWC STJR—2024 Span Tables for Joists and Rafters R502.3R802.4.1R802.5.1</p>					
AWPA	American Wood Protection Council			NO	
<p>C1—03 All Timber Products—Preservative Treatment by Pressure Processes R902.2</p> <p>M4—21 Standard for the Handling, Storage, Field Fabrication, and Field Treatment of Preservative-treated Wood Products R304.1.1R305.1.2</p> <p>U1—23 USE CATEGORY SYSTEM: User Specification for Treated Wood Except Commodity Specification H R304.1R402.1.2R504.3R703.6.3R905.7.6Table R905.8.5R905.8.7</p>					
AWS	American Welding Society			NO	
<p>A5.8M/A5.8—2019 Specification for Filler Metals for Brazing and Braze Welding P3003.6.1</p>					

2024 Code Section	TITLE OR SUBJECT	Reviewer Comments	Cost Yes/No	Amendment Needed Yes/No	TAG Comments/ Recommendation
ANSI/AWS A5.31M/A5.31—2012 Specification for Fluxes for Brazing and Braze Welding Edition: 2nd M2103.3M2202.2P2906.15					
AWWA	American Water Works Association			NO	
<p>C104/A21.4—16 Cement-mortar Lining for Ductile-iron Pipe and Fittings P2906.4</p> <p>C110/A21.10—21 Ductile-iron and Gray-iron Fittings Table P2906.6P3002.3</p> <p>C115/A21.15—20 Flanged Ductile-iron Pipe with Ductile-iron or Gray-iron Threaded Flanges Table P2906.4</p> <p>C151/A21.51—17 Ductile-Iron Pipe, Centrifugally Cast Table P2906.4</p> <p>C153/A21.53—19 Ductile-Iron Compact Fittings Table P2906.6</p> <p>C500—19 Metal-Seated Gate Valves for Water Supply Service Table P2903.10.4</p> <p>C504—15 Rubber-Seated Butterfly Valves Table P2903.10.4</p> <p>C507—18 Ball Valves, 6 In. Through 60 In. (150 mm through 1,500 mm) Table P2903.10.4</p> <p>C510—17 Double Check Valve Backflow Prevention Assembly</p>					

2024 Code Section	TITLE OR SUBJECT	Reviewer Comments	Cost Yes/No	Amendment Needed Yes/No	TAG Comments/ Recommendation
Table P2902.3P2902.3.6 C511—17 Reduced-pressure Principle Backflow Prevention Assembly Table P2902.3P2902.3.5P2902.5.1 C901—20 Polyethylene (PE) Pressure Pipe and Tubing 3/4 Inch (19 mm) through 3 In. (76 mm), for Water Service P2906.4 C903—21 Polyethylene-Aluminum-Polyethylene (PE-AL-PE) Composite Pressure Pipe, (12 mm) (1/2 in.) through 51 mm (2 in.), for Water Service Table M2105.4 C904—16 Crosslinked Polyethylene (PEX) Pressure Tubing, 1/2 in. (13 mm) through 3 in. (76 mm), for Water Service P2906.4					
CISPI	Cast Iron Soil Pipe Institute			NO	
301—21 Standard Specification for Hubless Cast Iron Soil Pipe and Fittings for Sanitary and Storm Drain, Waste and Vent Piping Applications Table P3002.1(1)Table P3002.1(2)Table P3002.2Table P3002.3Table P3302.1 310—20 Standard Specification for Coupling for Use in Connection with Hubless Cast Iron Soil Pipe and Fittings for Sanitary and Storm Drain, Waste and Vent Piping Applications P3003.4.3					
CPA	Composite Panel Association			NO	
ANSI A135.4—2012(R2020) Basic Hardboard Table R602.3(2) ANSI A135.5—2012(R2020) Prefinished Hardboard Paneling R702.5					

2024 Code Section	TITLE OR SUBJECT	Reviewer Comments	Cost Yes/No	Amendment Needed Yes/No	TAG Comments/ Recommendation
	ANSI A135.6—2012(R2020) Engineered Wood Siding R703.5 ANSI A135.7—2012(R2020) Engineered Wood Trim R703.5 ANSI A208.1—2016 Particleboard R503.3.1R602.1.9R605.1				
CRRC	Cool Roof Rating Council			NO	
	ANSI/CRRC-S100-2021 Standard Test Methods for Determining Radiative Properties of Materials Table N1107.2N1108.2.1.3N1108.2.1.3.1				
CSA	CSA Group			NO	
	A112.18.6—2021/CSA B125.6—21 Flexible Water Connectors P2906.7 A112.19.5—2022/CSA B45.15—22 Flush Valves and Spuds for Water Closets, Urinals and Tanks Table P2701.1 A112.19.7—20/CSA B45.10—20 Hydromassage Bathtub Systems Table P2701.1 A257.2—19 Reinforced Circular Concrete Culvert, Storm Drain, Sewer Pipe and Fittings Table P3002.2P3003.13 A257.3—19 Joints for Circular Concrete Sewer and Culvert Pipe, Manhole Sections and Fittings Using Rubber Gaskets P3003.5P3003.13				

2024 Code Section	TITLE OR SUBJECT	Reviewer Comments	Cost Yes/No	Amendment Needed Yes/No	TAG Comments/ Recommendation
	<p>AAMA/WDMA/CSA 101/I.S.2/A440—22 North American Fenestration Standard/Specification for Windows, Doors, and Skylights R609.3N1102.5.3</p> <p>ANSI/CSA/IGSHPA C448 Series—16(R2021) Design and Installation of Ground Source Heat Pump Systems for Commercial and Residential Buildings Table M2105.4Table M2105.5</p> <p>ASME A17.1—2022/CSA B44—22 Safety Code for Elevators and Escalators R323.1</p> <p>ASME A112.3.4—2018/CSA B45.9—18(R2023) Macerating Toilet Systems and Waste Pumping Systems for Plumbing Fixtures Table P2701.1P3007.5</p> <p>ASME A112.4.2—2021/CSA B45.16—21 Personal Hygiene Devices for Water Closets P2722.5</p> <p>ASME A112.18.1—2023/CSA B125.1—23 Plumbing Supply Fittings Table P2701.1P2708.4P2708.5P2722.1P2722.3P2902.2Table P2903.10.4</p> <p>ASME A112.18.2—2023/CSA B125.2—23 Plumbing Waste Fittings Table P2701.1P2702.2</p> <p>ASME A112.19.1—2023/CSA B45.2—23 Enamelled Cast-iron and Enamelled Steel Plumbing Fixtures Table P2701.1P2711.1</p> <p>ASME A112.19.2—2023/CSA B45.1—23 Ceramic Plumbing Fixtures Table P2701.1P2705.1P2711.1P2712.1P2712.2P2712.9</p> <p>ASME A112.19.3—2022/CSA B45.4—22 Stainless Steel Plumbing Fixtures Table P2701.1P2705.1P2711.1P2712.1</p> <p>ASSE 1002—2020/ASME A112.1002—2020/CSA B125.12—20 Anti-Siphon Fill Valves for Water Closet Tanks</p>				

2024 Code Section	TITLE OR SUBJECT	Reviewer Comments	Cost Yes/No	Amendment Needed Yes/No	TAG Comments/ Recommendation
	<p>Table P2701.1Table P2902.3P2902.4.1 ASSE 1016—2017/ASME 112.1016—2017/CSA B125.16—(R2022) Performance Requirements for Automatic Compensating Valves for Individual Showers and Tub/Shower Combinations Table P2701.1P2708.4P2722.2 ASSE 1070—2020/ASME A112.1070—2020/CSA B125.70—20 Performance Requirements for Water Temperature Limiting Devices P2713.3P2721.2P2724.1 B55.1—20 Test Method for Measuring Efficiency and Pressure Loss of Drain Water Heat Recovery Units N1103.5.4 B55.2—20 Drain Water Heat Recovery Units N1103.5.4 B64.1.1—21 Vacuum Breakers, Atmospheric Type (AVB) Table P2902.3P2902.3.2 B64.1.2—21 Pressure Vacuum Breakers (PVB) Table P2902.3P2902.3.4 B64.1.3—21 Spill Resistant Pressure Vacuum Breakers (SRPVB) Table P2902.3 B64.2—21 Vacuum Breakers, Hose Connection Type (HCVB) Table P2902.3P2902.3.2 B64.2.1—21 Hose Connection Vacuum Breakers (HCVB) with Manual Draining Feature Table P2902.3P2902.3.2 B64.2.1.1—21 Hose Connection Dual Check Vacuum Breakers (HCDVB) Table P2902.3P2902.3.2 B64.2.2—21</p>				

2024 Code Section	TITLE OR SUBJECT	Reviewer Comments	Cost Yes/No	Amendment Needed Yes/No	TAG Comments/ Recommendation
	<p>Vacuum Breakers, Hose Connection Type (HCVB) with Automatic Draining Feature Table P2902.3P2902.3.2 B64.3—21</p> <p>Dual Check Backflow Preventers with Atmospheric Port (DCAP) Table P2902.3P2902.3.2P2902.5.1 B64.4—21</p> <p>Reduced Pressure Principle (RP) Backflow Preventers Table P2902.3P2902.3.5 B64.4.1—21</p> <p>Reduced Pressure Principle Backflow Preventers for Fire Protection Systems (RPF) Table P2902.3P2902.3.5 B64.5—21</p> <p>Double Check Backflow Preventers (DCVA) Table P2902.3P2902.3.6 B64.5.1—21</p> <p>Double Check Valve Backflow Preventers for Fire Protection Systems (DCVAF) Table P2902.3P2902.3.6 B64.6—21</p> <p>Dual Check Valve (DuC) Backflow Preventers Table P2902.3P2902.3.7 B64.7—21</p> <p>Laboratory Faucet Vacuum Breakers (LFVB) Table P2902.3P2902.3.2 B125.3—23</p> <p>Plumbing Fittings Table P2701.1P2713.3P2721.2Table P2902.3P2902.4.1Table P2903.10.4 B137.1—23</p> <p>Polyethylene (PE) Pipe, Tubing and Fittings for Cold-water Pressure Services Table P2906.4Table P2906.6 B137.2—23</p> <p>Polyvinylchloride (PVC) Injection-moulded Gasketed Fittings for Pressure Applications Table P2906.6</p>				

2024 Code Section	TITLE OR SUBJECT	Reviewer Comments	Cost Yes/No	Amendment Needed Yes/No	TAG Comments/ Recommendation
B137.3—23	Rigid Polyvinylchloride (PVC) Pipe and Fittings for Pressure Applications Table P2906.4 Table P2906.6 P3003.9.2				
B137.5—23	Crosslinked Polyethylene (PEX) Tubing Systems for Pressure Applications Table P2906.4 Table P2906.5 Table P2906.6				
B137.6—23	Chlorinated polyvinylchloride (CPVC) Pipe, Tubing and Fittings For Hot- and Cold-water Distribution Systems Table P2906.4 Table P2906.5 Table P2906.6				
B137.9—23	Polyethylene/Aluminum/Polyethylene (PE-AL-PE) Composite Pressure-pipe Systems Table M2101.1 Table P2906.4				
B137.10—23	Crosslinked Polyethylene/Aluminum/Crosslinked Polyethylene (PEX-AL-PEX) Composite Pressure-pipe Systems Table M2101.1 Table P2906.4 Table P2906.5 Table P2906.6 P2906.12.1				
B137.11—23	Polypropylene (PP-R & PP-RCT) pipe and fittings for pressure applications Table P2906.4 Table P2906.5 Table P2906.6				
B137.18—23	Polyethylene of Raised Temperature (PE-RT) Tubing Systems for Pressure Applications Table M2101.1 Table M2105.4 Table M2105.5 Table P2906.4 Table P2906.5 Table P2906.6				
B181.1—21	Acrylonitrile-Butadiene-Styrene (ABS) Drain, Waste, and Vent Pipe and Pipe Fittings Table P3002.1(1) Table P3002.1(2) Table P3002.3 P3003.3.2				
B181.2—21	Polyvinylchloride (PVC) Drain and Chlorinated Polyvinylchloride (CPVC) Drain, Waste, and Vent Pipe and Pipe Fittings Table P3002.1(1) Table P3002.1(2) P3003.9.2 P3008.3				
B181.3—21	Polyolefin and Polyvinylidene Fluoride (PVDF) Laboratory Drainage Systems Table P3002.1(1) Table P3002.1(2) Table P3002.2 Table P3002.3 P3003.11.1				
B182.1—21	Plastic Drain and Sewer Pipe and Pipe Fittings				

2024 Code Section	TITLE OR SUBJECT	Reviewer Comments	Cost Yes/No	Amendment Needed Yes/No	TAG Comments/ Recommendation
	<p>Table P3302.1 B182.2—21 PSM Type polyvinylchloride (PVC) Sewer Pipe and Fittings Table P3002.2Table P3302.1 B182.4—21 Profile Polyvinylchloride (PVC) Sewer Pipe and Fittings Table P3002.2Table P3302.1 B182.6—21 Profile Polyethylene (PE) Sewer Pipe and Fittings for Leak-Proof Sewer Applications Table P3302.1 B182.8—21 Profile Polyethylene (PE) Storm Sewer and Drainage Pipe and Fittings Table P3302.1 B356—10(R2020) Water Pressure Reducing Valves for Domestic Water Supply Systems P2903.3.1 B483.1—22 Drinking Water Treatment Systems P2909.1P2909.2 B602—20 Mechanical Couplings for Drain, Waste and Vent Pipe and Sewer Pipe P3003.3.1P3003.4.3P3003.5P3003.9.1P3003.10P3003.12.2P3003.13 C22.2 No. 218.1—13(R2017) Spas, Hot Tubs and Associated Equipment M2006.1 C22.2 No. 236—15 Heating and Cooling Equipment M2006.1 CAN/CSA-C439—18 Laboratory methods of test for rating the performance of heat/energy-recovery ventilators Table N1103.6.2 CSA 8—93</p>				

2024 Code Section	TITLE OR SUBJECT	Reviewer Comments	Cost Yes/No	Amendment Needed Yes/No	TAG Comments/ Recommendation
	<p>Requirements for Gas-fired Log Lighters for Wood Burning Fireplaces G2433.1 CSA A257.1—19 Non-reinforced Circular Concrete Culvert, Storm Drain, Sewer Pipe and Fittings Table P3002.2 CSA B45.5—22/IAPMO Z124—2022 Plastic Plumbing Fixtures Table P2701.1P2711.1P2711.2P2712.1 CSA B55.1—20 Test Method for Measuring Efficiency and Pressure Loss of Drain Water Heat Recovery Units N1103.5.3 CSA B55.2—20 Drain Water Heat Recovery Units N1103.5.3 CSA B805—22/ICC 805—2022 Rainwater Harvesting Systems P2912.1 CSA O325—21 Construction Sheathing R503.2.1R602.1.8R604.1R803.2.1 CSA/ANSI FC 1—21/CSA C22.2 No. 62282-2-100—21 Fuel Cell Technologies—Part 3-100: Stationary Fuel Cell Power Systems—Safety M1903.1 O437-Series—93(R2011) Standards on OSB and Waferboard R503.2.1R602.1.8R604.1R803.2.1 P.4.1—2021 Testing method for measuring fireplace efficiency N1103.13.1 UL/CSA 60335-2-40—2022 Household and Similar Electrical Appliances—Safety—Part 2-40: Particular Requirements for Electrical Heat Pumps, Air-Conditioners and Dehumidifiers</p>				

2024 Code Section	TITLE OR SUBJECT	Reviewer Comments	Cost Yes/No	Amendment Needed Yes/No	TAG Comments/ Recommendation
M1403.1M1412.1M1413.1					
CTA	Consumer Technology Association Technology and Standards Department			NO	
ANSI/CTA-2045-A—2018 Modular Communications Interface for Energy Management Table N1103.5.4N1108.2.8.1 ANSI/CTA-2045-B—2018 Modular Communications Interface for Energy Management Table N1103.5.4N1108.2.8.1					
DASMA	Door and Access Systems Manufacturers Association International			NO	
ANSI/DASMA 105—2020 Test Method for Thermal Transmittance and Air Infiltration of Garage Doors and Rolling Doors N1101.10.3 ANSI/DASMA 108—2017 Standard Method for Testing Sectional Doors, Rolling Doors and Flexible Doors: Determination of Structural Performance Under Uniform Static Air Pressure Difference R609.4 ANSI/DASMA 115—2017 Standard Method for Testing Sectional Doors, Rolling Doors and Flexible Doors: Determination of Structural Performance Under Missile Impact and Cyclic Wind Pressure R301.2.1.2					

2024 Code Section	TITLE OR SUBJECT	Reviewer Comments	Cost Yes/No	Amendment Needed Yes/No	TAG Comments/ Recommendation
DHA	Decorative Hardwoods Association			NO	
ANSI/HPVA HP-1—2022 American National Standard for Hardwood and Decorative Plywood R702.5					
DOC	US Department of Commerce			NO	
PS 1—22 Structural Plywood R404.2.1 Table R404.2.3 R503.2.1 R602.1.8 R604.1 R803.2.1 PS 2—18 Performance Standard for Wood Structural Panels R404.2.1 Table R404.2.3 R503.2.1 R602.1.8 R604.1 R803.2.1 PS 20—20 American Softwood Lumber Standard R404.2.1 R502.1.1 R602.1.1 R802.1.1					
DOE	US Department of Energy			NO	
10 CFR, Part 430—2021 Energy Conservation Program for Consumer Products: Energy and Water Conservation Standards and their compliance dates. Table N1103.6.2 N1104.1 Table N1105.4.2(1) Table N1108.2.6					
FEMA	Federal Emergency Management Agency			NO	
FEMA TB-2—23 Flood Damage-resistant Materials Requirements R306.1.8 FEMA TB-11—23 Crawlspace Construction for Buildings Located in Special Flood Hazard Area					

2024 Code Section	TITLE OR SUBJECT	Reviewer Comments	Cost Yes/No	Amendment Needed Yes/No	TAG Comments/ Recommendation
R408.7					
GA	Gypsum Association			NO	
GA-253—2021 Application of Gypsum Sheathing Table R602.3(1)					
IAPMO	IAPMO Group			NO	
CSA B45.5—22/IAPMO Z124—2022 Plastic Plumbing Fixtures Table P2701.1P2711.1P2711.2P2712.1					
ICC	International Code Council			NO	
ANSI/APSP/ICC 14—2019 American National Standard for Portable Electric Spa Energy Efficiency N1103.11 ANSI/PHTA/ICC 15—2021 American National Standard for Residential Swimming Pool and Spa Energy Efficiency N1103.12 ANSI/RESNET/ICC 301—2022 Standard for the Calculation and Labeling of the Energy Performance of Low-rise Dwelling and Sleeping Units Using the Energy Rating Index—includes Addendum A Approved July 28, 2022; and Addendum B Approved October 12, 2022 N1105.5.3N1106.4N1106.5N1106.7.1N1106.7.6 ANSI/RESNET/ICC 380—2022 Standard for Testing Airtightness of Building, Dwelling Unit and Sleeping Unit Enclosures; Airtightness of Heating and Cooling Air Distribution Systems and Airflow of Mechanical Ventilation Systems Table N1105.4.2(1)N1102.5.1.2N1103.3.7N1103.3.8N1103.6.3 IBC—24 International Building Code® R101.2R202R301.1.1R301.1.3R301.2.1.1R301.2.2.1.1R301.2.2.1.2R301.3Table R302.1(1)Table R302.1(2)R302.2.1R302.2.2R302.3R302.15.4R322.1R322.3R324.5R403.1.8Table R602.10.3(3)Table					

2024 Code Section	TITLE OR SUBJECT	Reviewer Comments	Cost Yes/No	Amendment Needed Yes/No	TAG Comments/ Recommendation
R606.12.2.1R609.2R905.10.3N1101.6N1101.10.1N1101.10.2N1101.11N1102.1.1N1102.2.11.1N1104.1.2N1109.2N1111.1.1.3G2402.3	ICC 400—2022 Standard on the Design and Construction of Log Structures R301.1.1R502.1.4R602.1.4R703.1R802.1.3N1102.1Table N1102.5.1.1 ICC 500—2020 ICC/NSSA Standard for the Design and Construction of Storm Shelters R307.1N1102.6 ICC 600—2020 2020 Standard for Residential Construction in High-Wind Regions R301.2.1.1 ICC 900/SRCC 300—2020 Solar Thermal System Standard M2301.2.2.2M2301.2.3M2301.2.6M2301.2.7M2301.2.8M2301.2.10M2301.4 ICC 901/SRCC 100—2020 Solar Thermal Collector Standard M2301.3.1 ICC 1100—2019 Standard for Spray-applied Polyurethane Foam Plastic Insulation R303.1.1 ICC A117.1—2017 Standard for Accessible and Usable Buildings and Facilities R323.3 IEBC—24 International Existing Building Code® R110.2N1109.2 IECC—06 International Energy Conservation Code® N1101.6 IECC—24 International Energy Conservation Code® Table N1105.4.2(1)N1101.1N1103.8				

2024 Code Section	TITLE OR SUBJECT	Reviewer Comments	Cost Yes/No	Amendment Needed Yes/No	TAG Comments/ Recommendation
	IFC—24 International Fire Code® R102.6R329.2N1109.2M2201.7G2402.3G2412.2 IFGC—24 International Fuel Gas Code® N1109.2G2401.1G2402.3G2423.1 IMC—24 International Mechanical Code® N1103.3.5N1103.3.6N1103.6N1109.2G2402.3 IPC—24 International Plumbing Code® R903.4.1N1109.2G2402.3P2601.1 IPMC—24 International Property Maintenance Code® R102.6N1109.2 IPSDC—24 International Private Sewage Disposal Code® R306.1.7 ISPSC—24 International Swimming Pool and Spa Code® R328.1				
IEC	IEC Regional Centre for North America			NO	
	IEC 62746-10-1—2018 Systems interface between customer energy management system and the power management system - Part 10-1: Open automated demand response N1108.2.8.1				
MSS	Manufacturers Standardization			NO	

2024 Code Section	TITLE OR SUBJECT	Reviewer Comments	Cost Yes/No	Amendment Needed Yes/No	TAG Comments/ Recommendation
	Society of the Valve and Fittings Industry				
<p>SP-42—2022 Corrosion Resistant Gate, Globe, Angle and Check Valves with Flanged and Butt Weld Ends (Classes 150, 300 & 600) Table P2903.10.4</p> <p>SP-58—2023 Pipe Hangers and Supports—Materials, Design, Manufacture, Selection, Application, and Installation G2418.2</p> <p>SP-67—2022 Butterfly Valves Table P2903.10.4</p> <p>SP-70—2023 Gray Iron Gate Valves, Flanged and Threaded Ends Table P2903.10.4</p> <p>SP-71—2023 Gray Iron Swing Check Valves, Flanged and Threaded Ends Table P2903.10.4</p> <p>SP-72—2023 Ball Valves with Flanged or Butt-Welding Ends for General Service P2903.10.4</p> <p>SP-78—2023 Cast Iron Plug Valves, Flanged and Threaded Ends Table P2903.10.4</p> <p>SP-80—2019 Bronze Gate, Globe, Angle and Check Valves Table P2903.10.4</p> <p>SP-110—2023 Ball Valves, Threaded, Socket-Welding, Solder Joint, Grooved and Flared Ends (incl. a 2010 Errata Sheet) Table P2903.10.4</p> <p>SP-122—2023 Plastic Industrial Ball Valves Table P2903.10.4</p>					

2024 Code Section	TITLE OR SUBJECT	Reviewer Comments	Cost Yes/No	Amendment Needed Yes/No	TAG Comments/ Recommendation
SP-139—2022 Copper Alloy Gate, Globe, Angle, and Check Valves for Low Pressure/ Low Temperature Plumbing Applications Table P2903.10.4					
NFPA	National Fire Protection Association			NO	
13D—22 Standard for the Installation of Sprinkler Systems in One- and Two-Family Dwellings and Manufactured Homes R309.1.1R309.2.1R329.6.2.1P2904.1P2904.6.1 13R—22 Standard for the Installation of Sprinkler Systems in Low-Rise Residential Occupancies R314.5 31—20 Standard for the Installation of Oil-Burning Equipment M1701.1M1801.3.1M1805.3M2201.2 58—23 Liquefied Petroleum Gas Code G2412.2G2414.5.2 70—23 National Electrical Code R107.3R329.3R330.6R905.15R905.16R907.1N1104.7.4N1104.7.5N1109.2E3401.1E3401.2E4301.1Table E4303.2E4304.3E4304.4 72—22 National Fire Alarm and Signaling Code R310.1R310.7.1 85—23 Boiler and Combustion Systems Hazards Code G2452.1 211—22 Standard for Chimneys, Fireplaces, Vents, and Solid Fuel-Burning Appliances R1002.5G2427.5.5.1 259—23					

2024 Code Section	TITLE OR SUBJECT	Reviewer Comments	Cost Yes/No	Amendment Needed Yes/No	TAG Comments/ Recommendation
	<p>Standard for Test Method for Potential Heat of Building Materials R303.5.7R303.5.8 275—22</p> <p>Standard Method of Fire Tests for the Evaluation of Thermal Barriers R303.4 276—23</p> <p>Standard Method of Fire Test for Determining the Heat Release Rate of Roofing Assemblies with Combustible Above-Deck Roofing Components R906.1 286—23</p> <p>Standard Methods of Fire Tests for Evaluating Contribution of Wall and Ceiling Interior Finish to Room Fire Growth R302.9.4R303.6 501—22</p> <p>Standard on Manufactured Housing R202 720—15</p> <p>Standard for the Installation of Carbon Monoxide (CO) Detection and Warning Equipment R311.7.1R311.7.2 853—20</p> <p>Standard for the Installation of Stationary Fuel Cell Power Systems M1903.1</p>				
NFRC	National Fenestration Rating Council			NO	
	<p>100—2023</p> <p>Procedure for Determining Fenestration Products <i>U</i>-Factors N1101.10.3 200—2023</p> <p>Procedure for Determining Fenestration Product Solar Heat Gain Coefficient and Visible Transmittance at Normal Incidence N1101.10.3 400—2023</p>				

2024 Code Section	TITLE OR SUBJECT	Reviewer Comments	Cost Yes/No	Amendment Needed Yes/No	TAG Comments/ Recommendation
Procedure for Determining Fenestration Product Air Leakage N1102.5.3					
NSF	NSF International			NO	
14—2020 Plastics Piping System Components and Related Materials M1301.4P2609.3P2909.3 41—2018 Non-liquid Saturated Treatment Systems P2725.1 42—2021 Drinking Water Treatment Units—Aesthetic Effects P2909.1P2909.3 44—2017 Residential Cation Exchange Water Softeners P2909.1P2909.3 53—2020 Drinking Water Treatment Units—Health Effects P2909.1P2909.3 58—2020 Reverse Osmosis Drinking Water Treatment Systems P2909.2P2909.3 61—2020 Drinking Water System Components—Health Effects P2609.5P2722.1P2903.10.4P2906.4P2906.5P2906.6P2909.3 62—2021 Drinking Water Distillation Systems P2909.1 350—2020 Onsite Residential and Commercial Water Reuse Treatment Systems P2911.6.1 358-1—2021					

2024 Code Section	TITLE OR SUBJECT	Reviewer Comments	Cost Yes/No	Amendment Needed Yes/No	TAG Comments/ Recommendation
<p>Polyethylene Pipe and Fittings for Water-Based Ground-Source “Geothermal” Heat Pump Systems Table M2105.4Table M2105.5 358-2—2017 Polypropylene Pipe and Fittings for Water-Based Ground-Source “Geothermal” Heat Pump Systems Table M2105.4Table M2105.5 358-3—2021 Cross-linked Polyethylene (PEX) Pipe and Fittings for Water-Based Ground-Source “Geothermal” Heat Pump Systems Table M2105.4Table M2105.5 358-4—2018 Polyethylene of Raised Temperature (PE-RT) Tubing and Fittings for Water-Based Ground-Source (Geothermal) Heat Pump Systems Table M2105.4Table M2105.5 359—2018 Valves for Crosslinked Polyethylene (PEX) Water Distribution Tubing Systems Table P2903.10.4 372—2020 Drinking Water Systems Components—Lead Content P2906.2.1 NSF/ANSI/CAN 50—2020 Equipment and Chemicals for Swimming Pools, Spas, Hot Tubs and Other Recreational Water Facilities P2911.8.1</p>					
Open ADR	OpenADR Alliance			NO	
<p>OpenADR 2.0a and 2.0b—2019 Profile Specification Distributed Energy Resources N1108.2.8.1</p>					
PHTA	Pool and Hot Tub Alliance			NO	
<p>ANSI/ PHTA/ICC 15— 2021 American National Standard for Residential Swimming Pool and Spa Energy Efficiency N1103.12 ANSI/APSP/ICC 14—2019</p>					

2024 Code Section	TITLE OR SUBJECT	Reviewer Comments	Cost Yes/No	Amendment Needed Yes/No	TAG Comments/ Recommendation
American National Standard for Portable Electric Spa Energy Efficiency N1103.11					
PTI	Post-Tensioning Institute			NO	
PTIDC10.5—19 Standard Requirements for Design and Analysis of Shallow Concrete Foundations on Expansive and Stable Soils R506.2					
RESNET	Residential Energy Services Network Inc			NO	
ANSI/RESNET/ICC 301—2022 Standard for the Calculation and Labeling of the Energy Performance of Dwelling and Sleeping Units using an Energy Rating Index-- includes Addendum A Approved July 28, 2022; and Addendum B Approved October 12, 2022 N1105.5.3N1106.4N1106.5N1106.7.1N1106.7.6 ANSI/RESNET/ICC 380—2022 Standard for Testing Airtightness of Building, Dwelling Unit, and Sleeping Unit Enclosures; Airtightness of Heating and Cooling Air Distribution Systems; and Airflow of Mechanical Ventilation Systems Table N1105.4.2(1)N1102.5.1.2N1103.3.7N1103.3.8N1103.6.3					
SMACNA	Sheet Metal and Air Conditioning Contractors National Association Inc			NO	
ANSI/SMACNA 4th Edition—2020 HVAC Duct Construction Standards—Metal and Flexible, (ANSI/SMACNA 006—2020) M1601.4.1 SMACNA—2021 Fibrous Glass Duct Construction Standards, 8th edition M1601.1.1M1601.4.1					
TMS	The Masonry Society			NO	

2024 Code Section	TITLE OR SUBJECT	Reviewer Comments	Cost Yes/No	Amendment Needed Yes/No	TAG Comments/ Recommendation
402—2022 Building Code Requirements for Masonry Structures R404.1.2R606.1R606.1.1R606.12.1R606.12.2.3.1R606.12.3.1R703.12 403—2017 Direct Design Handbook for Masonry Structures R606.1R606.1.1R606.12.1R606.12.3.1 404—2023 Standard for the Design of Architectural Cast Stone R606.1 602—2022 Specification for Masonry Structures R606.2.10R606.2.13R703.12					
TPI	Truss Plate Institute			NO	
ANSI/TPI 1—2022 National Design Standard for Metal Plate Connected Wood Truss Construction R502.12.1R802.10.2					
UL	UL LLC			NO	
17—2008 Vent or Chimney Connector Dampers for Oil-Fired Appliances—with Revisions through September 2013 M1802.2.2 55A—2004 Materials for Built-Up Roof Coverings R905.9.2 58—2018 Steel Underground Tanks for Flammable and Combustible Liquids M2201.1 80—2007 Steel Tanks for Oil-Burner Fuel—with Revisions through April 2019 M2201.1 103—2010					

2024 Code Section	TITLE OR SUBJECT	Reviewer Comments	Cost Yes/No	Amendment Needed Yes/No	TAG Comments/ Recommendation
	<p>Factory-built Chimneys for Residential Type and Building Heating Appliances—with Revisions through September 2021 R202R1005.3G2430.1 127—2011</p> <p>Factory-Built Fireplaces—with Revisions through February 2020 R1001.11R1004.1R1004.4R1004.5R1005.4N1102.5.2G2445.7 174—2004</p> <p>Household Electric Storage Tank Water Heaters—with Revisions through October 2021 M2005.1 180—2019</p> <p>Liquid-Level Indicating Gauges for Oil Burner Fuels and Other Combustible Liquids—with Revisions through August 2021 M2201.5 181—2013</p> <p>Factory-Made Air Ducts and Air Connectors M1601.1.1M1601.4.1 181A—2013</p> <p>Closure Systems for Use with Rigid Air Ducts and Air Connectors—with Revisions through March 2017 M1601.2M1601.4.1 181B—2013</p> <p>Closure Systems for Use with Flexible Air Ducts and Air Connectors—with Revisions through March 2017 M1601.4.1 217—2015</p> <p>Smoke Alarms—with Revisions through April 2021 R310.1.1R311.1.1 263—2011</p> <p>Fire Test of Building Construction and Materials—with Revisions through August 2021 Table R302.1(2)R302.2R302.2.1R302.2.2R302.4.1R302.11.1R606.2.2 268—2016</p> <p>Smoke Detectors for Fire Alarm Systems—with Revisions through October 2019 R310.7.1R310.7.4R311.7.4 325—2017</p> <p>Door, Drapery, Gate, Louver and Window Operators and Systems—with Revisions through February 2020 R317.4</p>				

2024 Code Section	TITLE OR SUBJECT	Reviewer Comments	Cost Yes/No	Amendment Needed Yes/No	TAG Comments/ Recommendation
<p>343—2008 Pumps for Oil-Burning Appliances—with Revisions through December 2017 M2204.1</p> <p>378—2006 Draft Equipment—with Revisions through September 2013 M1804.2.6G2427.3.3</p> <p>441—2016 Gas Vents—with Revisions through August 2019 G2426.1G2427.6.1</p> <p>467—2013 Grounding and Bonding Equipment G2411.2.5</p> <p>484 —2014 Standard for Room Air Conditioners—with Revisions through May 2019 M1404.1</p> <p>507—2017 Electric Fans—with Revisions through May 2020 M1503.2</p> <p>508—2018 Industrial Control Equipment—with Revisions through July 2021 M1411.9.1</p> <p>515—2015 Electrical Resistance Heat Tracing for Commercial Applications N1103.5.1.2</p> <p>536—2021 Flexible Metallic Hose M2202.3</p> <p>580—2006 Test for Uplift Resistance of Roof Assemblies—with Revisions through March 2019 R905.4.4.1R905.9.4R905.10.5R905.11.4R905.12.4R905.13.4R905.14.4</p> <p>641—2010 Type L Low-Temperature Venting Systems—with Revisions through April 2018</p>					

2024 Code Section	TITLE OR SUBJECT	Reviewer Comments	Cost Yes/No	Amendment Needed Yes/No	TAG Comments/ Recommendation
	R202R1003.11.5M1804.2.4G2426.1G2427.6.1 651—2011 Schedule 40 and Schedule 80, Rigid PVC Conduit and Fittings—with Revisions through March 2020 G2414.5.3 705—2017 Power Ventilators—with Revisions through August 2021 M1502.4.4 723—2018 Standard for Test for Surface Burning Characteristics of Building Materials R202R302.9.3R302.9.4R302.10.1R302.10.2R302.15R303.3R303.5.9R303.5.11R507.2.2.2R703.14.3M1601.3M1601.5.2P2801.5 726—1995 Oil-Fired Boiler Assemblies—with Revisions through October 2013 M2001.1.1M2006.1 727—2018 Oil-Fired Central Furnaces M1402.1 729—2003 Oil-Fired Floor Furnaces—with Revisions through November 2016 M1408.1 730—2003 Oil-Fired Wall Furnaces—with revisions through November 2016 M1409.1 732—2018 Oil-Fired Storage Tank Water Heaters—with Revisions through August 2018 M2005.1 737—2011 Fireplaces Stoves M1414.1M1901.2 790—2004 Standard Test Methods for Fire Tests of Roof Coverings—with Revisions through October 2018 R302.2.4R902.1 795—2016				

2024 Code Section	TITLE OR SUBJECT	Reviewer Comments	Cost Yes/No	Amendment Needed Yes/No	TAG Comments/ Recommendation
	<p>Commercial-Industrial Gas Heating Equipment—with Revisions through 2020 G2442.1G2452.1 834—2004 Heating, Water Supply, and Power Boilers—Electric—with Revisions through July 2019 M2001.1.1 842—2019 Valves for Flammable Fluids M2204.2 858—2014 Household Electric Ranges—with Revisions through September 2019 M1503.2M1901.2 875—2009 Electric Dry-bath Heaters—with Revisions through January 2021 M1902.2 896—1993 Oil-Burning Stoves—with Revisions through November 2016 M1410.1 907—2016 Fireplace Accessories R1001.13 923—2013 Microwave Cooking Appliances—with Revisions through August 2020 M1503.2M1504.1M1901.2 959—2010 Medium Heat Appliance Factory-Built Chimneys—with Revisions through August 2019 R1005.6 1026—2012 Household Electric Cooking and Food Serving Appliances—with Revisions through March 2021 M1901.2 1040—1996 Fire Test of Insulated Wall Construction—with Revisions through April 2017 R303.6</p>				

2024 Code Section	TITLE OR SUBJECT	Reviewer Comments	Cost Yes/No	Amendment Needed Yes/No	TAG Comments/ Recommendation
1042—2009	Electric Baseboard Heating Equipment—with Revisions through February 2021 M1405.1				
1256—2002	Fire Test of Roof Deck Construction—with Revisions through August 2018 R906.1 1261—2001				
1479—2015	Electric Water Heaters for Pools and Tubs—with Revisions through September 2017 M2006.1				
1482—2011	Fire Tests of Penetration Firestops—with Revisions through May 2021 R302.4.1.2				
1563—2009	Solid-Fuel Type Room Heaters—with Revisions through February 2020 R1002.2 R1002.5 M1410.1				
1618—2015	Electric Spas, Equipment Assemblies, and Associated Equipment—with Revisions through September 2020 M2006.1				
1693—2010	Wall Protectors, Floor Protectors, and Hearth Extensions—with Revisions through January 2018 R1004.2 M1410.2				
1703—2002	Electric Radiant Heating Panels and Heating Panel Sets—with Revisions through October 2011 M1406.1				
1715—1997	Flat-Plate Photovoltaic Modules and Panels—with Revisions through November 2019 R329.3.1 R902.4				
1738—2010	Fire Test of Interior Finish Material—with revisions through April 2017 R303.6				
	Venting Systems for Gas-Burning Appliances, Categories II, III and IV—with Revisions through August 2021				

2024 Code Section	TITLE OR SUBJECT	Reviewer Comments	Cost Yes/No	Amendment Needed Yes/No	TAG Comments/ Recommendation
	<p>G2426.1G2427.4.1G2427.4.1.1G2427.4.2 1741—2010 Inverters, Converters, Controllers and Interconnection System Equipment with Distributed Energy Resources—with Revisions through June 2021 R329.3.1R330.6 1777—2015 Chimney Liners—with Revisions through April 2019 R1003.11.1R1003.18M1801.3.4G2425.12G2425.15.4G2427.5.1G2427.5.2 1897—2015 Uplift Tests for Roof Covering Systems—with Revisions through September 2020 R905.4.4.1R905.9.4R905.10.5R905.11.4R905.12.4R905.13.4R905.14.4 1995—2015 Heating and Cooling Equipment—with Revisions through August 2018 M1402.1M1403.1M1407.1M1412.1M1413.1M2006.1 1996—2009 Electric Duct Heaters—with Revisions through September 2021 M1402.1M1407.1 2034—2017 Single and Multiple Station Carbon Monoxide Alarms—with Revisions through September 2018 R310.1.1R311.1.1 2075—2013 Gas and Vapor Detectors and Sensors—with Revisions through August 2021 R310.7.4R311.7.1R311.7.4 2158A—2013 Clothes Dryer Transition Duct—with Revisions through October 2021 M1502.4.3G2439.7.3 2200—2020 Stationary Engine Generator Assemblies R331.1 2523—2009: Solid Fuel-Fired Hydronic Heating Appliances, Water Heaters and Boilers—with Revisions through March 2018 M2001.1.1M2005.1</p>				

2024 Code Section	TITLE OR SUBJECT	Reviewer Comments	Cost Yes/No	Amendment Needed Yes/No	TAG Comments/ Recommendation
2703—2014	Mounting Systems, Mounting Devices, Clamping/Retention Devices and Ground Lugs for Use with Flat-Plate Photovoltaic Modules and Panels—with Revisions through March 2021 R902.4				
3741—2020	Photovoltaic Hazard Control R329.6R329.6.3R329.6.4				
7103—2019	Outline of Investigation for Building-Integrated Photovoltaic Roof Coverings R902.3R905.15.4Table R905.15.6R905.16.5R905.16.7				
9540—2020	Standard for Energy Storage Systems and Equipment—with Revisions through April 2021 R330.2R330.6				
61730-1—2017	Photovoltaic (PV) Module Safety Qualification — Part 1: Requirements for Construction—with Revisions through April 2020 R329.3.1				
61730-2—2017	Photovoltaic (PV) Module Safety Qualification—Part 2: Requirements for Testing—with Revisions through April 2020 R329.3.1R905.15.4R905.16.5				
UL 2202—2009	Electric Vehicle (EV) Charging System—with revisions through February 2018 R317.6				
UL 2594—2016	Standard for Electric Vehicle Supply Equipment R317.6				
UL/CSA 60335-2-40—2022	Household and Similar Electrical Appliances—Safety—Part 2-40: Particular Requirements for Electrical Heat Pumps, Air-Conditioners and Dehumidifiers M1402.1M1403.1M1412.1M1413.1M2006.1				

2024 Code Section	TITLE OR SUBJECT	Reviewer Comments	Cost Yes/No	Amendment Needed Yes/No	TAG Comments/ Recommendation
WDMA	Window and Door Manufacturers Association			NO	
AAMA/WDMA/CSA 101/I.S.2/A440—22 North American Fenestration Standard/Specification for Windows, Doors, and Skylights R324.6.9R609.3N1102.5.3 I.S. 11—23 Industry Standard Analytical Method for Design Pressure (DP) Ratings of Fenestration Products R324.6.9.1R609.3.1					
WMA	World Millwork Alliance			NO	
ANSI WMA 100—2023 Standard Method of Determining Structural Performance Ratings of Side-Hinged Exterior Door Systems and Procedures for Component Substitution R609.3					
APPENDIX AA BOARD OF APPEALS					
This Appendix Not Adopted					
APPENDIX AB PERMIT FEES					
This Appendix Not Adopted					
APPENDIX AC RESERVED					
Appendix Reserved					
APPENDIX BA MANUFACTURED HOUSING USED AS DWELLINGS					
This Appendix Not Adopted					
APPENDIX BB TINY HOUSES					
Entire Appendix Moved from AQ to BB. No technical language changes. See also, Existing Amendments Report					
APPENDIX BC ACCESSORY DWELLING UNITS					
New appendix This Appendix Not Adopted					
APPENDIX BD HOME DAY CARE OCCUPANCY					

2024 Code Section	TITLE OR SUBJECT	Reviewer Comments	Cost Yes/No	Amendment Needed Yes/No	TAG Comments/ Recommendation
This Appendix Not Adopted					
APPENDIX BE RADON CONTROL METHODS					
BE 103.2	Requirements	Well drained soils do not require a sand layer	Decrease, See RB295-22	NO	
<p>BE103.2 Subfloor preparation.</p> <p>A layer of gas-permeable material shall be placed under all concrete slabs and other floor systems that directly contact the ground and are within the walls of the <i>living spaces</i> of the <i>building</i>, to facilitate future installation of a <i>subslab depressurization system</i>, if needed.</p> <p>The gas-permeable layer shall consist of one of the following:</p> <ol style="list-style-type: none"> 1.A uniform layer of clean aggregate, not less than 4 inches (102 mm) thick. The aggregate shall consist of material that will pass through a 2-inch (51 mm) sieve and be retained by a 1/4-inch (6.4 mm) sieve. 2.A uniform layer of sand (native or fill), not less than 4 inches (102 mm) thick, overlain by a layer or strips of geotextile drainage matting designed to allow the lateral flow of soil gases. <ul style="list-style-type: none"> Exception: A sand base course is not required under geotextile drainage matting where the concrete slab is installed on well-drained ground or sand-gravel mixture soils classified as Group 1 according to the United Soil Classification as detailed in Table R401.4.1(2). 3.Other materials, systems or floor designs with demonstrated capability to permit depressurization across the entire subfloor area. 					
BE103.3	Requirements	Correlates requirement with main body of the code	No	NO	

2024 Code Section	TITLE OR SUBJECT	Reviewer Comments	Cost Yes/No	Amendment Needed Yes/No	TAG Comments/ Recommendation
	<p>BE103.3 Soil-gas-retarder. Flexible sheeting material complying with Section R506.3.3 shall be placed on top of the gas-permeable layer prior to casting the slab or placing the floor assembly to serve as a <i>soil-gas-retarder</i> by bridging any cracks that develop in the slab or floor assembly, and to prevent concrete from entering the void spaces in the aggregate base material. The sheeting shall cover the entire floor area with separate sections of sheeting lapped not less than 12 inches (305 mm). The sheeting shall fit closely around any pipe, wire or other penetrations of the material. Punctures or tears in the material shall be sealed or covered with additional sheeting.</p>				
APPENDIX BF PATIO COVERS					
This Appendix Not Adopted					
APPENDIX BG SOUND TRANSMISSION					
This Appendix Not Adopted					
APPENDIX BH AUTOMATIC VEHICULAR GATES					
This Appendix Not Adopted					
APPENDIX BI LIGHT STRAW-CLAY CONSTRUCTION					
This Appendix Not Adopted					
APPENDIX BJ STRAWBALE CONSTRUCTION					
This Appendix Not Adopted					
APPENDIX BK COB CONSTRUCTION (MONOLITHIC ADOBE)					
This Appendix Not Adopted					
APPENDIX BL HEMP-LIME (HEMPCRETE) CONSTRUCTION					
This Appendix Not Adopted					
APPENDIX BM 3D-PRINTED BUILDING CONSTRUCTION					
This Appendix Not Adopted					
APPENDIX BN EXTENDED PLATE WALL CONSTRUCTION					
This Appendix Not Adopted					

2024 Code Section	TITLE OR SUBJECT	Reviewer Comments	Cost Yes/No	Amendment Needed Yes/No	TAG Comments/ Recommendation
APPENDIX BO EXISTING BUILDINGS AND STRUCTURES					
This Appendix Not Adopted					
APPENDIX CA SIZING AND CAPACITIES OF GAS PIPING					
This Appendix Not Adopted					
APPENDIX CB SIZING OF VENTING SYSTEMS SERVING APPLIANCES EQUIPPED WITH DRAFT HOODS, CATEGORY I APPLIANCES AND APPLIANCES LISTED FOR USE WITH TYPE B VENTS					
This Appendix Not Adopted					
APPENDIX CC RECOMMENDED PROCEDURE FOR SAFETY INSPECTION OF AN EXISTING APPLIANCE INSTALLATION					
This Appendix Not Adopted					
APPENDIX CD PIPING STANDARDS FOR VARIOUS APPLICATIONS					
This Appendix Not Adopted					
APPENDIX CE VENTING METHODS					
This Appendix Not Adopted					
APPENDIX CF SIZING OF WATER PIPING SYSTEM					
This Appendix Not Adopted					
APPENDIX CG NONSEWERED SANITATION SYSTEMS					
This Appendix Not Adopted					
APPENDIX CH PRIVATE SEWAGE DISPOSAL					
This Appendix Not Adopted					
APPENDIX NA RESERVED					
Appendix Reserved					
APPENDIX NB SOLAR-READY PROVISIONS-DETACHED ONE- AND TWO-FAMILY DWELLINGS AND TOWNHOUSES					
Entire Appendix Moved from AT to NB. No technical language changes. See also, Existing Amendments Report					
APPENDIX NC ZERO NET ENERGY RESIDENTIAL BUILDING PROVISIONS					
This Appendix Not Adopted					
APPENDIX ND ELECTRIC ENERGY STORAGE PROVISIONS					
This Appendix Not Adopted					
APPENDIX NE ELECTRIC VEHICLE CHARGING INFRASTRUCTURE					
This Appendix Not Adopted					
APPENDIX NF ALTERNATIVE BUILDING THERMAL ENVELOPE INSULATION R-VALUE OPTIONS					
This Appendix Not Adopted					
APPENDIX NG 2024 IECC STRETCH CODE					

2024 Code Section	TITLE OR SUBJECT	Reviewer Comments	Cost Yes/No	Amendment Needed Yes/No	TAG Comments/ Recommendation
		This Appendix Not Adopted			
	APPENDIX NH OPERATIONAL CARBON RATING AND ENERGY REPORTING				
		This Appendix Not Adopted			
	APPENDIX NI ON-SITE RENEWABLE ENERGY				
		This Appendix Not Adopted			
	APPENDIX NJ DEMAND RESPONSIVE CONTROLS				
		This Appendix Not Adopted			
	APPENDIX NK ELECTRIC-READY RESIDENTIAL BUILDING PROVISIONS				
		This Appendix Not Adopted			
	APPENDIX NL RENEWABLE ENERGY INFRASTRUCTURE				
		This Appendix Not Adopted			
	RESOURCE A ALL-ELECTRIC RESIDENTIAL BUILDINGS				
		This Resource Not Adopted			